

ELSTER JEAVONS S200

Slam Shut Valve

Brief information

Operation: The S200 Slam Shut Valve protects gas installations against dangerous under pressure and over pressure conditions and is normally fitted on the inlet side of the regulator.

An impulse pipe connects the diaphragm chamber to the outlet side of the regulator. When the pressure goes outside the predetermined values the trigger mechanism actuates and the valve slams shut.

The S200 is available with a visual valve position indicator and/or micro switch valve position indicator. Resetting can only be achieved manually, and an automatic integral vent valve ensures safe resetting procedures and eliminates costly by-pass systems. The S200 can be mounted in any orientation. The unit can be specified with the reset mechanism on either side of the body.

The Series 200 Slam Shut Valve has been designed to meet the requirements of BS EN 14382 and DIN3381

Application: All units are suitable for operation on natural, liquefied petroleum and manufactured gases. They can be installed in vertical or horizontal pipework.

Technical Data:

Maximum inlet pressure:	19 bar (275 psig)
Over pressure range:	25 mbar – 8 bar (10"wg – 116 psig)
Under pressure range:	5 – 2500 mbar (2"wg – 1004"wg)

Approval: The S200 has been approved to Modulus B + D of the PE(S)R 2016 for UKCA and PED 2014/68/EU for CE by DVGW (Approved Body LR0038/ Notified Body No. 0085). It is classified as Category IV equipment and a safety accessory.

Servicing: The S200 has been designed for ease of access, inspection and servicing of all internal components. A standard soft spares kit is available for all sizes.

DN50 Low Pressure	reference number SK209-01
DN50 High Pressure	reference number SK209-02
DN80 Low Pressure	reference number SK211-01
DN80 High Pressure	reference number SK211-02
DN100 Low Pressure	reference number SK212-01
DN100 High Pressure	reference number SK212-02



FEATURES & BENEFITS

Main Features

- Sizes DN50, DN80 & DN100
- Over pressure protection
- Under pressure protection
- Temperature range -20°C to +60°C
- Flanged connections to BS EN 1092-2 NP16 and impulse tapping connection to Rc1/4 unless otherwise requested.
- External impulse
- Spring loaded
- Full Bore Design
- Very low pressure drop

Options

- Visual Indicator
- Micro Switch



CONTROLS SUPPLY CHAIN
VALVES ACTUATORS INSTRUMENTATIONS

S200: Slam Shut Valve

1. Introduction

The Series 200 Slam shut valve is an extremely high integrity device ensuring positive operation to the closed position in the event of control equipment failure.

At the heart of the system is the ball bearing latch mechanism which has been well proven over the last two decades and is now the accepted standard against which other pressure operated security devices are judged.

This mechanism provides predictable repeatability set point for any pressure within extremely close tolerances and is unaffected by the mounting position of the valve.

In service the valve disc assembly is retained in the open position well away from the main gas flow. The bore of the valve is therefore completely uninterrupted resulting in low pressure losses and equally as important, minimal affect from gas turbulence on the valve assembly.

Among its innovative design features are automatic pressure equalising valve, valve position indicator and in line servicing of all components including the valve seat.

The Series 200 valve is pre-set to a desired safe pressure limit which will safeguard the downstream system or equipment and is automatically operated whenever this pressure limit is sensed. Re-arming is carried out manually.

Remote indication of operation - The Series 200 Slam Shut can be provided with a switching device which will give remote indication of operation.

2. Trip Mechanism

Mechanism - valve open

As all operating components are spring loaded and latching mechanisms positively located the Series 200 Slam Shut is completely unaffected by vibration or external forces. Actuation can only be achieved via sensed pressure reaching the set point.

In the trip mechanism a spring-loaded shaft (A) acts downwards on a series of ball bearings (B) tending to force them radially outwards.

The bearings are held against the shaft by the bearing cage (C) which is connected to the pressure sensing diaphragm (D). Diaphragm and bearing cage are spring loaded via the pressure setting springs (E) and (F).

The valve disc assembly (G) is retained in the open position via the spring clip (H) which locates in a recess in the shaft (A). The valve disc assembly is spring loaded to the closed position thus forcing the spring clip against the recess.

Valve Operation

As the sense pressure reaches the desired trip point it acts against the pressure sensing diaphragm and OPSS (E) or UPSS (F) pressure setting spring.

The bearing cage is lifted for OPSS or falls for UPSS allowing the ball bearings to move radially outwards against the bearing cage taper to a point where the shoulder diameter on the spring loaded shaft is free to pass through the bearings (TRIP POINT).

As the shaft moves through the bearings it releases the spring clip (H) thereby allowing the valve disc assembly to operate to the closed position.

If fitted the valve position indicator (J) indicates that the valve has moved to the closed position.

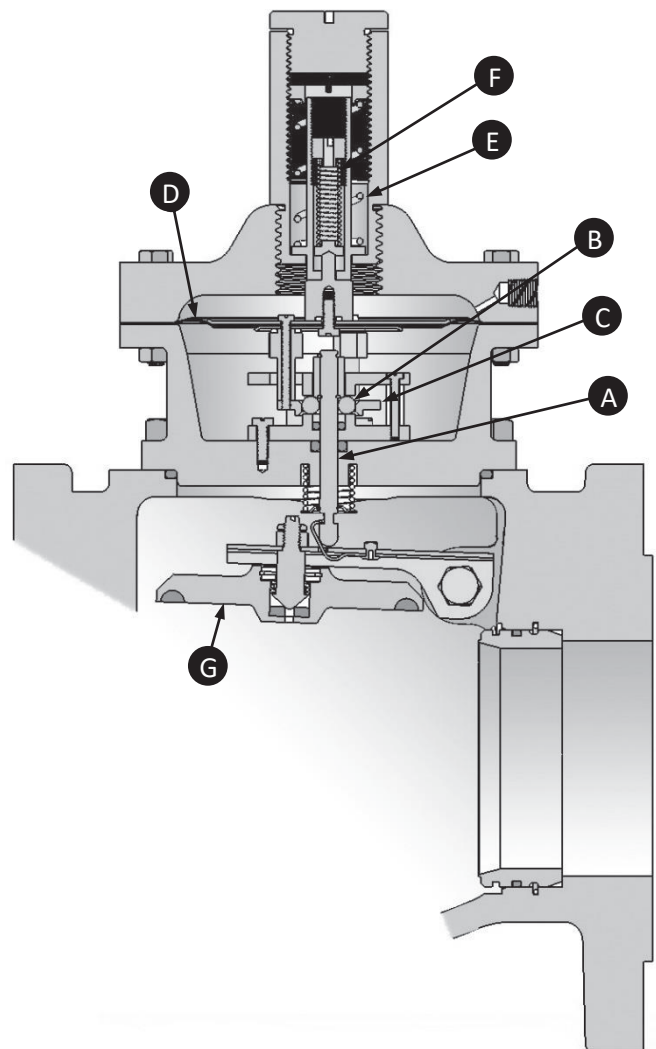

S200: Slam Shut Valve

3. Integral Pressure Equalising Valve

In the closed position pressure acts upon the valve ensuring positive lock up forces.

In order to re-arm the valve this pressure must first be equalised across the valve if damage to the mechanism is to be avoided.

In the Series 200 Slam Shut this is AUTOMATICALLY achieved when the re-arming procedure is undertaken. When the re-arming shaft is rotated a small valve incorporated into the main valve is opened allowing pressure to pass downstream. This device eliminates costly by-passes and potential damage due to neglect in carrying out equalising procedures.

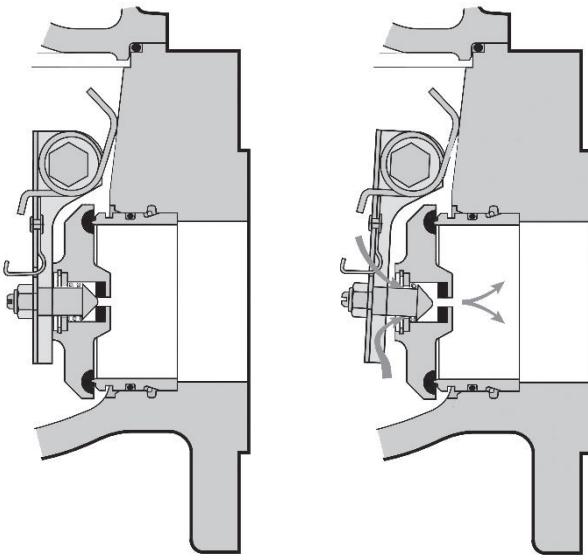

4. In-Line Servicing

All components have been designed such that complete servicing of the valve can be carried out with the body installed in the pipework.

5. Mounting Position

As all components in the valve are positively biased and located the valve can be installed in any position including inverted. However, care of the orientation of the breather hole. The actuating head is designed to be rotated to allow the breather vent to be positioned downwards to prevent moisture ingress.

$$\Delta P = \left(\frac{Q \sqrt{G}}{25 C_v} \right)^2 P_i$$

Q = m³/hr, cubic meters per hour at 1.01 bar abs. and 15.5°C (288°K)
 C_v = Valve Coefficient
 P_i = Inlet Pressure, bar abs.
 G = Specific Gravity of Gas (Air = 1)
 ΔP = Pressure drop across valve, bar ($P_i - P_o$)

Capacity

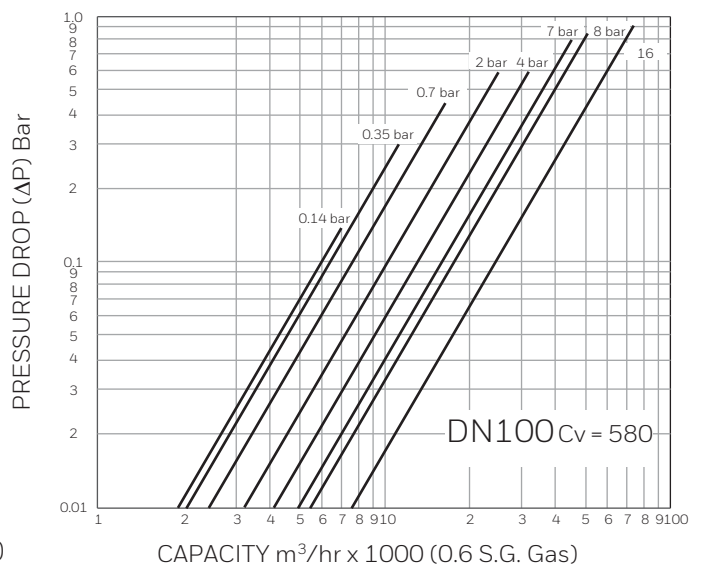
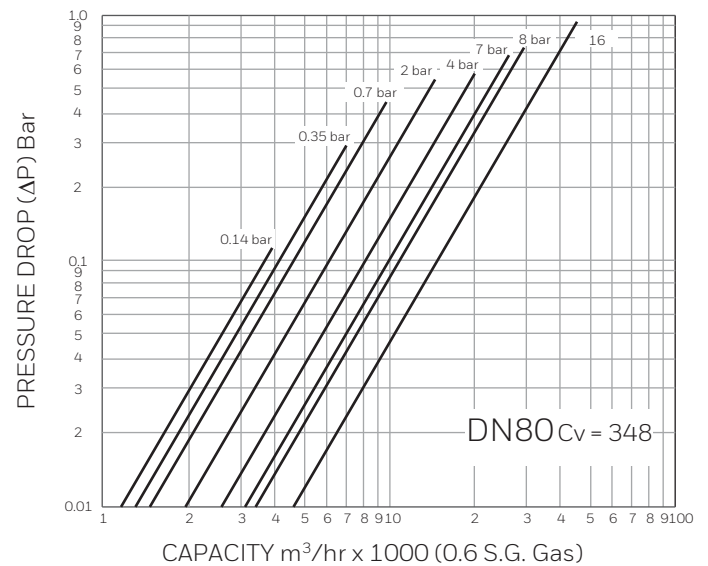
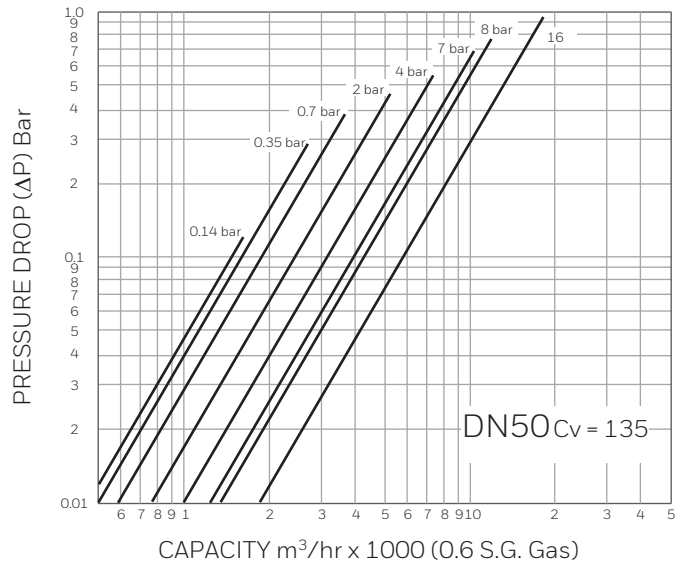

S200: Slam Shut Valve

Dimensions and Weights

Size	A	B L.P.	B H.P.	C	D	E	Weight (Kg)
50	180	242	263	83	166	111	13
80	220	255	275	100	200	124	17
100	270	282	302	110	220	150	24

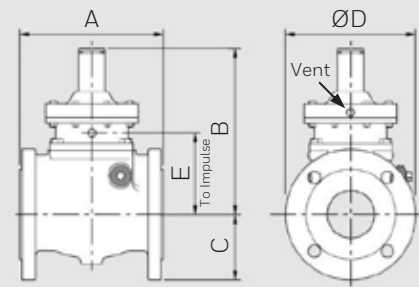

Trip Off Pressures

Over Pressure Range

Low Pressure				High Pressure			
Part No.	Colour Code	mbar	"wg	Part No.	Colour Code	bar	Psig
J10009-011	-	25 – 40	10 – 16	J10009-013	Red / Brown	0.7 – 1.4	10.1 – 20.3
J10009-012	Light Blue	35 – 70	14 – 28	J10009-014	Purple	1.4 – 2.1	20.3 – 30.5
J10009-013	Red / Brown	70 – 140	28 – 56	J10009-015	Orange / Yellow	2.1 – 3.5	30.5 – 50.7
J10009-014	Purple	140 – 210	56 – 84	J10009-016	Orange / Dark Green	3.5 – 7.0	50.7 – 101.5
J10009-015	Orange / Yellow	210 – 350	84 – 140	J10009-046	Orange / Purple	4.0 – 8.0	58.0 – 116.0
J10009-016	Orange / Dark Green	350 – 700	140 – 280				

Under Pressure Range

Low Pressure				High Pressure			
Part Number	Colour Code	mbar	"wg	Part Number	Colour Code	mbar	"wg
J10009-042	White / Black	5 – 15	2 – 6	J10009-042	White / Black	50 – 150	20 – 60
J10009-043	White / Orange	10 – 50	4 – 20	J10009-043	White / Orange	100 – 500	40 – 201
J10009-044	White / Red	40 – 120	16 – 48	J10009-044	White / Red	400 – 1200	160 – 482
J10009-045	White / Lt Blue	90 – 250	36 – 100	J10009-045	White / Lt Blue	900 – 2500	361 – 1004

Material Specifications

A summary of the material specification for the S200 is given for reference. All material has been selected to provide maximum durability and reliability in service.

Components	Specification
Body	Nodular Iron
Valve Seat	Stainless Steel
Actuating Mechanism	Aluminium Alloy
Sensing Diaphragm, Valve Discs and 'O' rings	Nitrile (Buna)
Loading Springs	Carbon Steel, Zinc Plated and Coated
Mechanism Springs	Stainless Steel Wire