

# Masoneilan™ Model 535H-536H

Pressure Regulator for  
Reducing, Back Pressure  
and Differential Service  
Steam, Gas or Liquid Service



# Table of Contents

General Data .....	2..	Bonnet Packing .....	4..
Numbering System .....	3..	Flow Coefficients - $C_v$ .....	5..
Seat Leakage .....	4..	Regulator Sizing .....	7..
Body Ratings and End Connections .....	4	Materials .....	13..
Standard Trim Materials .....	4	Dimensions and Weights .....	16

## Foreword

The Masoneilan Model 535H / 536H pressure regulators from Baker Hughes are designed to provide accurate reduced pressures of air, liquid, saturated and superheated steam. They are available in sizes ¾", 1", 1 ½" and 2" with full area and reduced trim to handle the small-to-moderate flow applications where IEC 60534-4/ASME/FCI 70.2 Class IV or VI shut-off is required.

For temperatures over the rating of the diaphragm material, the regulator must be mounted with the actuator below the centerline of the regulator body. The diaphragm will be protected from the high temperature by a condensate barrier in the sensing line and actuator diaphragm case. If installed otherwise, an adequate condensate barrier must be incorporated. Consult factory for more information.

Refer to Tech Spec 19537 for actuator selection.

## General Data

### Function

Pressure Reducing	535H
Differential Pressure Reducing	535H-50
Back Pressure	536H
Differential Back Pressure	536H-50

### Service

Steam, Gas, Liquids

### Body

Type: High Capacity Globe  
Flow Direction: Flow-to-Open

### Bonnet

Type: Bolted, Standard  
Bolted, Extension - Optional

### Body and Bonnet

Materials: Carbon Steel  
316 Stainless Steel  
Chrome-Molybdenum Steel

### Trim

Plug Type: Disc  
Seat Ring: Threaded or Quick Change  
Guide: Heavy Top Guided  
Capacity: Full Area, Reduced Capacity in All Sizes  
Characteristic: Quick Opening

### Actuator

Type: 10900 Series

# Numbering System

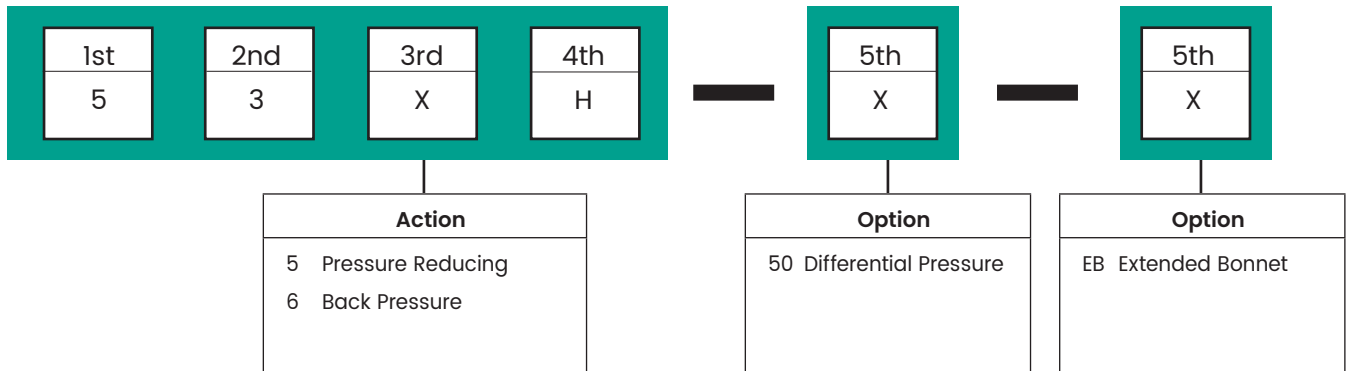

# Seat Leakage

Model	Seat Type	Leakage Class
535H - 536H Single Seat Regulator	Hard Seat	Class IV
	Soft Seat <sup>1,2</sup>	Class VI <sup>1,2</sup>

1. Soft Seat is only available for 535H.
2. Soft Seat is only available for regulators with seat-ring diameter > 20.62 mm. Temperature limits are -50°F (-46°C) up to 446°F (230°C).

# Body Ratings and End Connections 535H / 536H Single Seat Regulators

Flange Connections according to: ASME Class 150, 300 and 600  
 ISO PN 10, 16, 25, 40, 50 and 100  
 DIN PN 10, 16, 25, 40, 64 and 100 (Face to face according to ASME 300 up to PN 40 and to ASME 600 from PN 64 to 100)  
 Others available on request. Please consult factory.

RF Flanged    
  RT Joint    
  Butt Weld    
  Socket Weld    
  Threaded

Valve Size		ASME Class and Equivalent PN		
(mm)	(inches)	150	300	600
20	¾	<input type="checkbox"/> <input type="checkbox"/> <input checked="" type="checkbox"/> <input type="checkbox"/>	<input type="checkbox"/> <input type="checkbox"/> <input checked="" type="checkbox"/> <input type="checkbox"/>	<input type="checkbox"/> <input type="checkbox"/> <input checked="" type="checkbox"/> <input type="checkbox"/>
25	1	<input type="checkbox"/> <input type="checkbox"/> <input checked="" type="checkbox"/> <input type="checkbox"/>	<input type="checkbox"/> <input type="checkbox"/> <input checked="" type="checkbox"/> <input type="checkbox"/>	<input type="checkbox"/> <input type="checkbox"/> <input checked="" type="checkbox"/> <input type="checkbox"/>
40	1½	<input type="checkbox"/> <input type="checkbox"/> <input checked="" type="checkbox"/> <input type="checkbox"/>	<input type="checkbox"/> <input type="checkbox"/> <input checked="" type="checkbox"/> <input type="checkbox"/>	<input type="checkbox"/> <input type="checkbox"/> <input checked="" type="checkbox"/> <input type="checkbox"/>
50	2	<input type="checkbox"/> <input type="checkbox"/> <input checked="" type="checkbox"/> <input type="checkbox"/>	<input type="checkbox"/> <input type="checkbox"/> <input checked="" type="checkbox"/> <input type="checkbox"/>	<input type="checkbox"/> <input type="checkbox"/> <input checked="" type="checkbox"/> <input type="checkbox"/>

## Standard Trim Materials

Type	Plug	Seat Ring
Standard	316 St. St.	316 St. St.
Hard	316 St. St. w/hardfacing	316 St. St. w/hardfacing
Soft	316 St. St. w/Teflon® Insert	316 St. St.

Other options available on request. Please consult factory.

## Bonnet Packing

### Packing Options 535H / 536H and 535H / 536H EB

Body Ratings: ASME Class 150 to 600

Ref. No.	Temperature Range		-20°F (-29°C)	450°F (232°C)	650°F (343°C)
	Description	Materials			
11	Packing	Standard Bonnet	Carbon Core/PTFE jacketed packing		
	Packing	Extension Bonnet	Carbon Core/PTFE jacketed packing		

# Flow Coefficients - Cv

(Critical Flow Factor - Cf = 0.9)

Model: 535H / 536H<sup>1</sup>

Rating: ASME Class 150, 300, 600

Nominal Size		Travel		Stem Size		Nominal C <sub>v</sub>					
mm	inches	mm	inches	mm	inches						
20	¾	9.5	0.375	12.7	½	1.4	2.4	4.4	6.5	-	-
25	1	9.5	0.375	12.7	½	1.4	2.4	4.4	6.5	-	-
40	1½	9.5	0.375	12.7	½	1.4	2.4	4.4	6.5	19.5 <sup>2</sup>	27 <sup>2</sup>
50	2	9.5	0.375	12.7	½	1.4	2.4	4.4	6.5	19.5 <sup>2</sup>	27 <sup>2</sup>

1. 536H Limited to Quick Change Trim Only.

2. For regulators with a size 3-½ actuator, ranges 150-450, 150-300, or 400-750 psi, the C<sub>v</sub> is limited to 60% of the nominal rating: 11.7 instead of 19.5, 16.2 instead of 27.

## Available Spring Ranges

### Pressure Reducing or Back Pressure Actuator

Actuator Size	Travel		Spring Range		Maximum static allowable pressure for actuator	
	(inches)	(mm)	(psi)	(bar)	(psi)	(bar)
11	0.375	9.5	0.5 - 2	0.03 - 0.14	60	4.1
9	0.375	9.5	1.5 - 3	0.10 - 0.20	60	4.1
9	0.375	9.5	2 - 10	0.14 - 0.69	60	4.1
9	0.375	9.5	6 - 20	0.41 - 1.38	60	4.1
9	0.375	9.5	15 - 40	1.03 - 2.76	60	4.1
5	0.375	9.5	30 - 75	2.07 - 5.17	250	17.2
4	0.375	9.5	60 - 125	4.14 - 8.62	250	17.2
3½	0.375	9.5	80 - 250	5.51 - 17.24	250	17.2
3½	0.375	9.5	150 - 450 or 400 - 750 or 150 - 300	10.34 - 31.02 or 27.58 - 51.71 or 10.34 - 20.68	761	52.5

# Available Spring Ranges

## Differential Pressure Actuator (-50 Option)

### Low Pressure Application

Actuator size	Spring Range		Maximum static allowable pressure for actuator	
(inches)	(psi)	(bar)	(psi)	(bar)
5	3 – 12	0.20 – 0.83	250	17.2
5	10 – 35	0.67 – 2.41	250	17.2
5	30 – 75	2.07 – 5.17	250	17.2
4	60 – 125	4.14 – 8.62	250	17.2

### High Pressure Application

Actuator size	Spring Range		Maximum static allowable pressure for actuator	
(inches)	(psi)	(bar)	(psi)	(bar)
5	3 – 15	0.20 – 1.03	600	41.4
4	5 – 30	0.34 – 2.07	1000	69
4	10 – 60	0.67 – 4.14	1000	69
5	30 – 85	2.07 – 5.86	600	41.4
3½	75 – 185	5.15 – 12.75	1500	103.4
3½	100 – 330	6.89 – 22.75	1500	103.4

# Regulator Sizing

## Model 535H Series Pressure Reducing Regulators Capacity<sup>1</sup> Model 536H Series Back Pressure Regulator Capacity<sup>1</sup> Saturated Steam (lb/hr)

Inlet Pressure psig	Outlet Pressure psig	Rated C <sub>v</sub>					
		1.4	2.4	4.4	6.5	19.5	27
30	½-10	110	187	344	508	1526	2112
	20	83	142	260	384	1154	1601
50	½-20	161	275	505	745	2236	3096
	30	138	235	432	638	1915	2652
	40	101	174	319	472	1415	1959
60	½-25	186	319	584	864	2591	3588
	40	150	256	470	695	2083	2884
	50	110	188	345	509	1529	2117
75	½-30	229	392	719	1062	3185	4409
	50	183	313	574	848	2544	3522
	60	146	250	459	678	2033	2816
100	½-50	278	477	875	1292	3878	5370
	60	256	438	804	1188	3564	4935
	80	190	326	598	883	2650	3670
125	½-60	347	595	1084	1611	4834	6693
	80	302	518	949	1402	4206	5823
	100	235	402	737	1088	3265	4522
150	½-70	415	712	1305	1928	5784	8009
	100	348	595	1092	1613	4840	6701
	125	256	440	806	1191	3572	4946
160	½-80	432	740	1357	2004	6011	8323
	100	387	664	1217	1799	5396	7471
	120	327	560	1028	1518	4555	6308
	140	239	409	750	1108	3324	4602
175	½-90	465	787	1461	2159	6478	8969
	100	444	761	1396	2063	6187	8567
	125	377	647	1186	1770	5255	7277
	160	217	372	683	1009	3027	4192
200	½-100	534	915	1677	2477	7432	10290
	125	479	822	1506	2225	6676	9244
	160	367	629	1153	1703	5110	7076
225	½-120	583	999	1832	2706	8119	11242
	160	483	957	1516	2240	6720	9305
250	½-130	651	1117	2048	3025	9076	12567
	160	585	1002	1838	2714	8143	10812

1. Regulator Capacity Tables are included to provide convenience on common applications and are not intended to establish application limitations. If your particular service conditions are not listed in the Regulator Capacity Tables, calculate the required CV for selecting the optimum regulator size.

# Regulator Sizing

## Model 536H Series Back Pressure Regulator Capacity<sup>1</sup>

## Model 535H Series Pressure Reducing Regulators Capacity<sup>1</sup> Saturated Steam (kg/hr)

Inlet Pressure barg	Outlet Pressure barg	Rated C <sub>v</sub>					
		1.4	2.4	4.4	6.5	19.5	27
2.1	0.03-0.7	50	85	156	230	692	958
	1.4	38	64	118	174	523	726
3.4	0.03-1.4	73	125	229	338	1014	1404
	2.1	63	107	196	289	869	1203
	2.8	46	79	145	214	642	889
4.1	0.03-1.7	84	145	265	392	1175	1627
	2.8	68	116	213	315	945	1308
	3.4	50	85	156	231	694	960
5.2	0.03-2.1	104	178	326	482	1445	2000
	3.4	83	142	260	385	1154	1598
	4.1	66	113	208	308	922	1277
6.9	0.03-3.4	126	216	397	586	1759	2436
	4.1	116	199	365	539	1617	2238
	5.5	86	148	271	401	1202	1665
8.6	0.03-4.1	157	270	492	731	2193	3036
	5.5	137	235	430	636	1908	2641
	6.9	107	182	334	494	1481	2051
10.3	0.03-4.8	188	323	592	875	2624	3633
	6.9	158	270	495	732	2195	3040
	8.6	116	200	366	540	1620	2243
11.0	0.03-5.5	196	336	616	909	2727	3775
	6.9	176	301	552	816	2448	3389
	8.3	148	254	466	689	2066	2861
	9.7	108	186	340	503	1508	2087
12.1	0.03-6.2	211	357	663	979	2938	4068
	6.9	201	345	633	936	2806	3886
	8.6	171	293	538	803	2384	3301
	11	98	169	310	458	1373	1901
13.8	0.03-6.9	242	415	761	1124	3371	4667
	8.6	217	373	683	1009	3028	4193
	11	166	285	523	772	2318	3210
15.5	0.03-8.3	264	453	831	1227	3683	5099
	11	219	434	688	1016	3048	4221
17.2	0.03-9.0	295	507	929	1372	4117	5700
	11	265	454	834	1231	3694	4904

1. Regulator Capacity Tables are included to provide convenience on common applications and are not intended to establish application limitations. If your particular service conditions are not listed in the Regulator Capacity Tables, calculate the required CV for selecting the optimum regulator size.



# Regulator Sizing

Model 535H Series Pressure Reducing Regulators Capacity<sup>1</sup>

Model 536H Series Back Pressure Regulator Capacity<sup>1</sup>

Saturated Steam (scfm)

Inlet Pressure psig	Outlet Pressure psig	Rated C <sub>v</sub>					
		1.4	2.4	4.4	6.5	19.5	27
30	½-10	36	62	114	172	506	701
	20	27	47	87	130	383	531
50	½-20	54	91	167	252	742	1028
	30	45	78	144	216	636	880
	40	34	58	106	160	470	650
60	½-25	62	106	194	292	860	1191
	40	49	85	156	235	692	957
	50	36	62	114	173	508	703
75	½-30	76	130	238	359	1057	1463
	50	61	104	191	287	845	1169
	60	49	83	153	229	675	935
100	½-50	92	158	271	438	1288	1783
	60	85	146	267	402	1183	1638
	80	63	108	199	299	880	1218
125	½-60	115	198	362	545	1605	2222
	80	100	172	315	474	1396	1933
	100	78	134	245	368	1084	1501
150	½-70	138	236	433	652	1920	2659
	100	115	198	362	546	1607	2225
	125	85	146	268	403	1186	1642
160	½-80	143	246	450	678	1996	2763
	100	115	198	362	608	1791	2480
	120	109	186	341	514	1513	2094
	140	79	136	249	375	1103	1528
175	½-90	154	265	485	730	2150	2978
	100	147	253	463	698	2054	2844
	125	125	215	394	592	1744	2416
	160	72	184	227	341	1005	1392
200	½-100	177	304	557	838	2467	3417
	125	159	273	500	753	2217	3069
	160	122	209	383	576	1696	2349
225	½-120	194	331	608	916	2695	3732
	160	161	274	504	758	2231	3089
250	½-130	217	371	672	1023	3013	4172
	160	194	333	610	918	2703	3743

1. Regulator Capacity Tables are included to provide convenience on common applications and are not intended to establish application limitations. If your particular service conditions are not listed in the Regulator Capacity Tables, calculate the required CV for selecting the optimum regulator size.

# Regulator Sizing

Model 535H Series Pressure Reducing Regulators Capacity<sup>1</sup>

Model 536H Series Back Pressure Regulator Capacity<sup>1</sup>

Air (m<sup>3</sup>/hr)

Inlet Pressure barg	Outlet Pressure barg	Rated C <sub>v</sub>					
		1.4	2.4	4.4	6.5	19.5	27
2.1	0.03-0.7	61	105	194	292	860	1191
	1.4	46	80	148	221	651	902
3.4	0.03-1.4	92	155	284	428	1261	1747
	2.1	76	133	245	367	1081	1495
	2.8	58	99	180	272	799	1104
4.1	0.03-1.7	105	180	330	496	1461	2024
	2.8	83	144	265	399	1176	1626
	3.4	61	105	194	294	863	1194
5.2	0.03-2.1	129	221	404	610	1796	2486
	3.4	104	177	325	488	1436	1986
	4.1	83	141	260	389	1147	1589
6.9	0.03-3.4	156	268	460	744	2188	3029
	4.1	144	248	454	683	2010	2783
	5.5	107	183	338	508	1495	2069
8.6	0.03-4.1	195	336	615	926	2727	3775
	5.5	170	292	535	805	2372	3284
	6.9	133	228	416	625	1842	2550
10.3	0.03-4.8	234	401	736	1108	3262	4518
	6.9	195	336	615	928	2730	3780
	8.6	144	248	455	685	2015	2790
11.0	0.03-5.5	243	418	765	1152	3391	4694
	6.9	195	336	615	1033	3043	4214
	8.3	185	316	579	873	2571	3558
	9.7	134	231	423	637	1874	2596
12.1	0.03-6.2	262	450	824	1240	3653	5060
	6.9	250	430	787	1186	3490	4832
	8.6	212	365	669	1006	2963	4105
	11	122	313	386	579	1708	2365
13.8	0.03-6.9	301	516	946	1424	4191	5806
	8.6	270	464	850	1279	3767	5214
	11	207	355	651	979	2882	3991
15.5	0.03-8.3	330	562	1033	1556	4579	6341
	11	274	466	856	1288	3790	5248
17.2	0.03-9.0	369	630	1142	1738	5119	7088
	11	330	566	1036	1560	4592	6359

1. Regulator Capacity Tables are included to provide convenience on common applications and are not intended to establish application limitations. If your particular service conditions are not listed in the Regulator Capacity Tables, calculate the required CV for selecting the optimum regulator size.

# Regulator Sizing

Model 535H Series Pressure Reducing Regulators Capacity<sup>1</sup>  
 Model 536H Series Back Pressure Regulator Capacity<sup>1</sup>  
 Water (gpm)

Inlet Pressure minimum Outlet Pressure psig	Rated C <sub>v</sub>					
	1.4	2.4	4.4	6.5	19.5	27
10	4	8	14	20	62	86
15	6	9	17	25	75	105
20	7	11	20	29	87	121
25	8	12	22	33	97	135
30	8	13	24	36	107	148
35	8	14	26	38	116	160
40	9	15	28	41	123	170
45	9	16	29	43	131	181
50	10	17	31	46	138	191
60	11	19	34	50	151	209
70	12	20	37	54	163	226
80	13	21	40	58	174	241
90	13	23	42	62	185	256
100	14	24	44	65	195	270
120	16	27	48	71	214	295
140	17	29	52	77	231	319
160	18	30	56	82	247	342
180	19	32	59	87	265	363
210	21	35	64	94	283	391
230	22	36	67	98	296	410

1. Regulator Capacity Tables are included to provide convenience on common applications and are not intended to establish application limitations. If your particular service conditions are not listed in the Regulator Capacity Tables, calculate the required CV for selecting the optimum regulator size.

# Regulator Sizing

Model 535H Series Pressure Reducing Regulators Capacity<sup>1</sup>

Model 536H Series Back Pressure Regulator Capacity<sup>1</sup>

Water (lpm)

Inlet Pressure minimum Outlet Pressure barg	Rated C <sub>v</sub>					
	1.4	2.4	4.4	6.5	19.5	27
0.7	15	30	53	76	235	326
1.0	23	34	64	95	284	397
1.4	26	42	76	110	329	458
1.7	30	45	83	125	367	511
2.1	30	49	91	136	405	560
2.4	30	53	98	144	439	606
2.8	34	57	106	155	466	644
3.1	34	61	110	163	496	685
3.4	38	64	117	174	522	723
4.1	42	72	129	189	572	791
4.8	45	76	140	204	617	856
5.5	49	79	151	220	659	912
6.2	49	87	159	235	700	969
6.9	53	91	167	246	738	1022
8.3	61	102	182	269	810	1117
9.7	64	110	197	291	874	1208
11.0	68	114	212	310	935	1295
12.4	72	121	223	329	1003	1374
14.5	79	132	242	356	1071	1480
15.9	83	136	254	371	1120	1552

1. Regulator Capacity Tables are included to provide convenience on common applications and are not intended to establish application limitations. If your particular service conditions are not listed in the Regulator Capacity Tables, calculate the required CV for selecting the optimum regulator size.

# Materials of Construction

## 535H Series Standard Construction

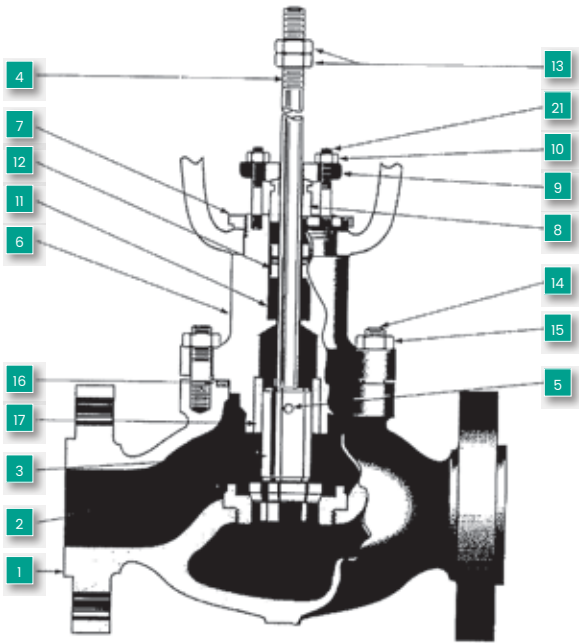

535 H Type Regulator  
Screwed Seat

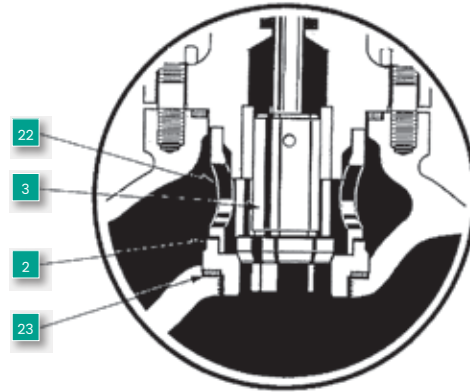

535 H Regulator  
Quick Change Trim (Detail)

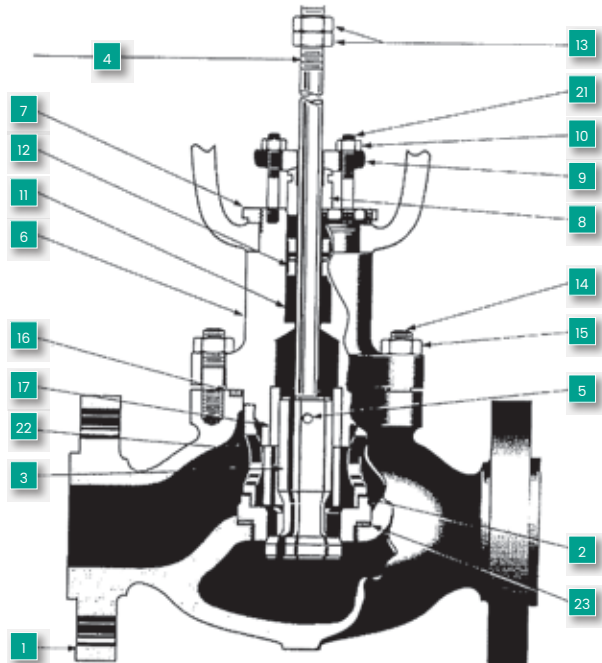

536 H Regulator  
Quick Change Trim Only (Detail)

# Materials of Construction

Materials ¾"–2" ASME Class 150–600

Carbon Steel Construction 535H / 536H and 535H / 536H EB

Valve Sizes: .75" to 2"

Body Ratings: ASME Class 150 to 600

Ref. No.	Temperature Range	-20°F (-29°C)	450°F (232°C)	650°F (343°C)
	Description	Materials		
1	Valve Body	Carbon Steel ASTM A216 Grade WCC		
2	Seat Ring	316 St. St. ASTM 479 TY 316		
3	Plug	316 St. St. ASTM 479 TY 316		
4	Plug Stem	316 St. St. ASTM 479 TY 316		
5	Plug Pin	316 St. St. ASTM 479 TY 316		
6	Valve Bonnet <sup>1</sup>	Carbon Steel ASTM A216 Grade WCC or ASTM A105		
7	Drive Nut	Carbon Steel SAE 1117 or ASTM A216 GR WCC		
8	Packing Follower	Austenitic 300 Series Stainless Steel		
9	Packing Flange	Zinc Dichromate Carbon Steel ASTM A105		
10	Packing Flange Nut	St. St. ASTM A194 GR B8		
12	Lantern Ring (Optional)	Austenitic 300 Series Stainless Steel		
13	Stem Locknuts	Alloy Steel ASTM A194 GR 2H Zinc dichromate plated		
14	Body Stud	Alloy Steel ASTM A193 GR B7		
15	Body Stud Nut	Carbon Steel ASTM A194 GR 2H		
16	Body Gasket	316L St. St. w/Flexible Graphite Filler (Spiral Wound)		
17	Guide Bushing	440C St. St. ASTM A276 TY 440C		
21	Packing Flange Stud	304 St. St. ASTM A193 GR B8		
22	Cage <sup>2</sup>	304 St. St. ASTM A351 GR CF8		
23	Seat Ring Gasket <sup>2</sup>	316L St. St. w/Flexible Graphite Filler (Spiral Wound)		

1. EB applies for temperature > of 450°F (232°C).
2. Required for Quick Change Trim Option Only.

# Materials of Construction

Materials ¾”-2” ASME Class 150-600

Stainless Steel Construction 535H / 536H and 535H / 536H EB

Valve Sizes: .75” to 2”

Body Ratings: ASME Class 150 to 600

Ref. No.	Temperature Range	-20°F (-29°C)	450°F (232°C)	650°F (343°C)
	Description	Materials		
1	Valve Body	316 Stainless Steel ASTM A351 Grade CF8M		
2	Seat Ring	316 St. St. ASTM 479 TY 316		
3	Plug	316 St. St. ASTM 479 TY 316		
4	Plug Stem	316 St. St. ASTM 479 TY 316		
5	Plug Pin	316 St. St. ASTM 479 TY 316		
6	Valve Bonnet <sup>1</sup>	316 Stainless Steel ASTM A351 Grade CF8M or ASTM A182 Grade F316		
7	Drive Nut	Carbon Steel SAE III7 or ASTM A216 GR WCC		
8	Packing Follower	Austenitic 300 Series Stainless Steel		
9	Packing Flange	Zinc Dichromate Carbon Steel ASTM A105		
10	Packing Flange Nut	St. St. ASTM A194 GR B8		
12	Lantern Ring (Optional)	Austenitic 300 Series Stainless Steel		
13	Stem Locknuts	Alloy Steel ASTM A194 GR 2H Zinc dichromate plated		
14	Body Stud	Alloy Steel ASTM A193 GR B7 Zinc dichromate plated		
		Alloy Steel ASTM A193 GR B7		
		ASTM A193 GR B8 <sup>2</sup>		
15	Body Stud Nut	Carbon steel ASTM A194 GR 2H Zinc dichromate plated		
		Carbon Steel ASTM A194 GR 2H		
		ASTM A194 GR 8 <sup>2</sup>		
16	Body Gasket	316L St. St. w/Flexible Graphite Filler (Spiral Wound)		
17	Guide Bushing	ASTM A479 TY S21800 Nirtonic 60	Stellite 6 <sup>2</sup>	
21	Packing Flange Stud	304 St. St. ASTM A193 GR B8		
22	Cage <sup>3</sup>	304 St. St. ASTM A351 GR CF8		
23	Seat Ring Gasket <sup>3</sup>	316L St. St. w/Flexible Graphite Filler (Spiral Wound)		

1. EB applies for temperature > of 450°F (232°C).
2. Bolting must be checked by Engineering Department.
3. For Quick Change Trim Only.

# Dimensions and Weights

## 535H / 536H Series Standard Construction

### English Units (in)

Valve Size		ASME Class 150 and equivalent PN				ASME Class 300 and equivalent PN				ASME Class 600 and equivalent PN				ASME Class 150-600 and equivalent PN	
inches	mm	RF		RTJ		RF		RTJ		RF		RTJ		Threaded & Socket Weld	
		A	B	A	B	A	B	A	B	A	B	A	B	A	B
¾	20	7.25	1.94	-	-	7.62	2.32	8.11	2.32	8.11	2.32	8.11	2.32	8.24	1.83
1	25	7.25	2.13	7.75	2.45	7.75	2.45	8.25	2.45	8.25	2.45	8.25	2.45	8.24	1.83
1½	40	8.75	2.50	9.25	3.06	9.25	3.06	9.76	3.06	9.88	3.06	9.88	3.06	9.88	2.50
2	50	10.00	3.00	10.5	3.25	10.50	3.25	11.10	3.25	11.25	3.25	11.38	3.25	11.24	3.00

### Metric Units (mm)

Valve Size		ASME Class 150 and equivalent PN				ASMEI Class 300 and equivalent PN				ASME Class 600 and equivalent PN				ASME Class 150-600 and equivalent PN	
mm	inches	RF		RTJ		RF		RTJ		RF		RTJ		Threaded & Socket Weld	
		A	B	A	B	A	B	A	B	A	B	A	B	A	B
20	¾	184	49	-	-	194	59	206	59	206	59	206	59	210	46
25	1	184	54	197	62	197	62	210	62	210	62	210	62	210	46
40	1½	222	64	235	78	235	78	248	78	251	78	251	78	251	64
50	2	254	76	267	83	267	83	282	83	286	83	289	83	286	76

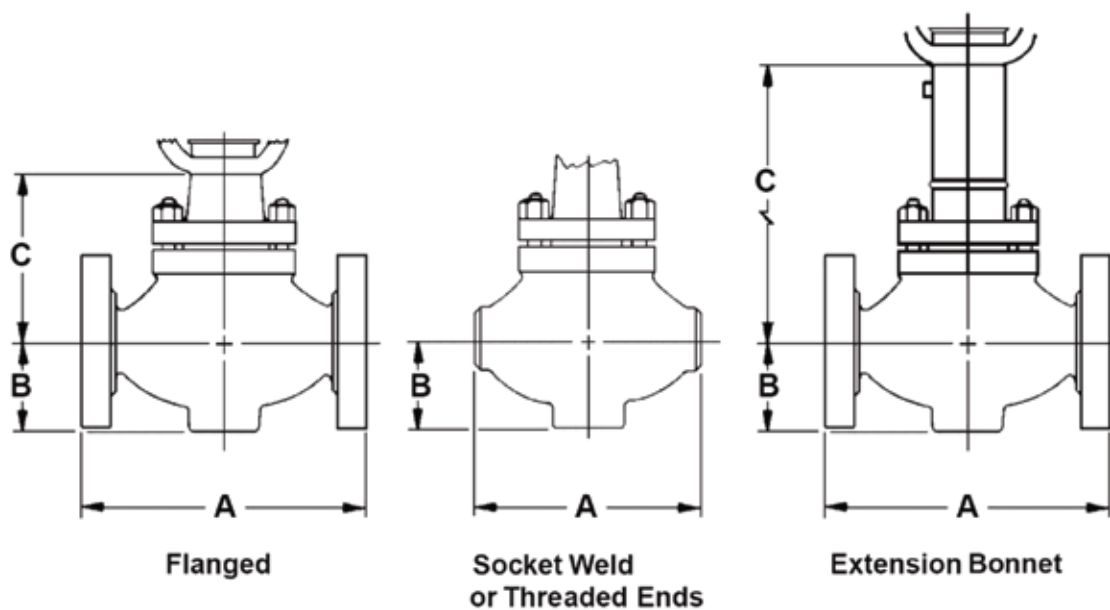



# Dimensions and Weights

## 535H / 536H Series Standard Construction

### English Units (in)

Valve Size		ASME Class 150-600 and equivalent PN	
inches	mm	C (Std. Bonnet)	C (EB Bonnet)
¾	20	5.51	9.92
1	25	5.51	9.92
1½	40	5.51	9.92
2	50	5.51	9.92

### Metric Units (mm)

Valve Size		ASME Class 150-600 and equivalent PN	
mm	inches	C (Std. Bonnet)	C (EB Bonnet)
20	¾	142	249
25	1	142	249
40	1 ½	140	254
50	2	140	254

# Dimensions and Weights

## 535H / 536H Series Standard Construction

### Body Sub-Assembly Weight English Units (lb)

Valve Size		ASME Class 150-600 and equivalent PN	ASME Class 150 and equivalent PN	ASME Class 300 and equivalent PN	ASME Class 600 and equivalent PN
inches	mm	Threaded & Socket Weld	Flanged		
¾	20	27	36	36	38
1	25	27	36	36	38
1½	40	36	49	49	53
2	50	45	58	58	64

### Body Sub-Assembly Weight Metric Units (Kg)

Valve Size		ASME Class 150-600 and equivalent PN	ASME Class 150 and equivalent PN	ASME Class 300 and equivalent PN	ASME Class 600 and equivalent PN
mm	inches	Threaded & Socket Weld	Flanged		
20	¾	12	16	16	17
25	1	12	16	16	17
40	1½	16	22	22	24
50	2	20	26	26	29





CONTROLS SUPPLY CHAIN

VALVES ACTUATORS INSTRUMENTATIONS