

# Masoneilan™ 10000 Series Double Ported Globe Valve



# Table of contents

Numbering System .....2.....

General Data .....2.....

Temperature Range/Seat Leakage.....3.....

Ratings/Connections .....4.....

Flow Coefficient - Rated  $C_v$ .....4.....

$C_v$  and  $F_L$  versus Travel.....5-6.....

Materials of Construction .....7-12.....

Valve Dimensions .....13-14.....

Valve Weights.....15.....

Actuator Dimensions and Weights.....16-17.....

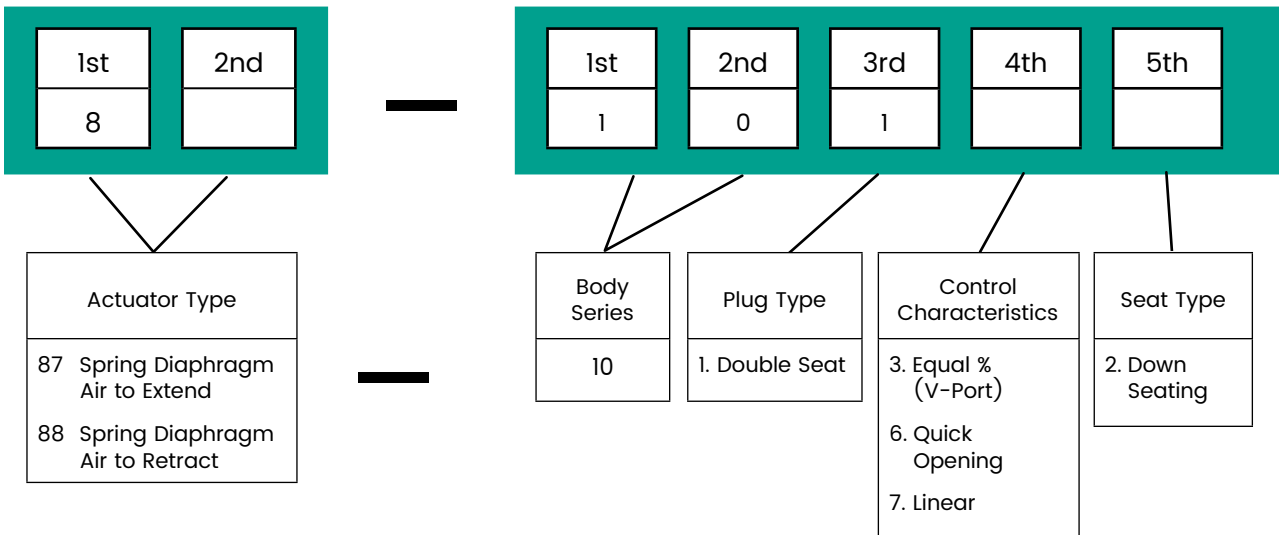

## General Data

### • Flow Direction

All trim: Flow through both ports

### • Body

Type: Double seat globe

### • Body Bonnet & Lower Flange

Type: Bolted

### • Bonnet & Lower Flange

Materials: Carbon steel  
Stainless steel  
Chrome-molybdenum steel

### • Trim

Plug type: Double seat  
V-port or contoured

Seat ring: Threaded

Guide: Heavy top and bottom guiding

Capacity: Full area  
Reduced capacity (0.4 factor)

$C_v$  ratio: 50:1

Flow characteristics: Equal percentage  
Quick opening  
Linear

### • Actuator

Type: Spring diaphragm  
Handwheel: Optional

# Temperature Range/Seat Leakage

Valve Size <sup>1</sup>		Body Rating	Body & Bonnet Material	Temperature Range				Seat Leakage IEC 60534-4 and ASME/FCI 70.2 Class
				Standard bonnet		Extension Bonnet		
inch	mm			min.	max.	min.	max.	
0.75 to 16	20 to 400	ASME Class 150 to 600 (PN 20 to 100)	Carbon Steel	-20°F (-29°C)	+450°F (+232°C)	-20°F (-29°C)	+800°F (+427°C)	II
			Stainless Steel	-20°F (-29°C)	+450°F (+232°C)	-148°F (-100°C)	+800°F (+427°C)	
			Chrome-Moly	32°F (0°C)	+450°F (+232°C)	32°F (0°C)	+800°F (+427°C)	
			NACE	-20°F (-29°C)	+450°F (+232°C)			

1. Maximum temperature shown is with PTFE packing and Low-E Packing. Extended max. operating temperature of 800°F (427°C) allowable with Graphite packing.
2. Low-E Packing for low emissions applications is limited to maximum pressure and temperature as shown in chart below.

**Pressure and Temperature Rating of Low-E Packing**

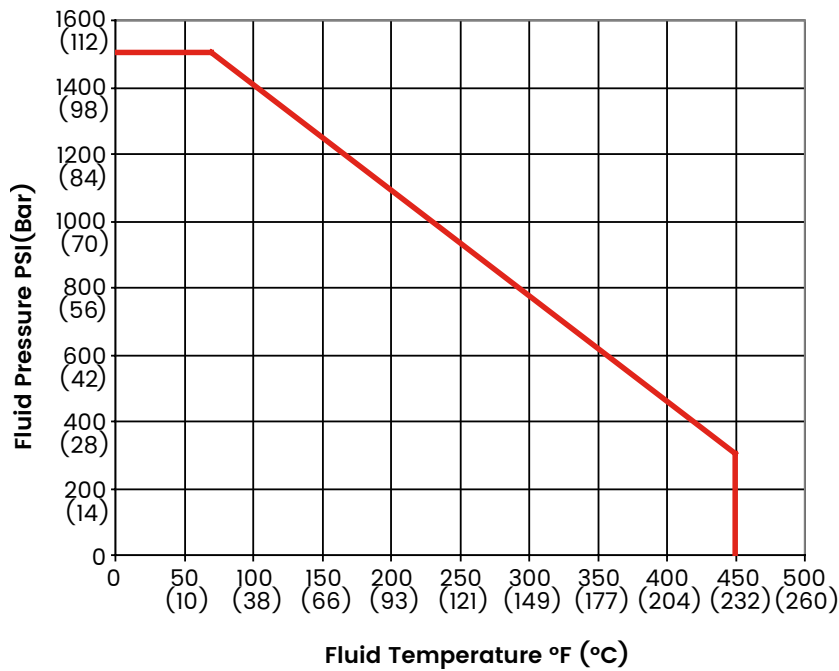

# Ratings/Connections

RF Flanged    Δ RT Joint    ■ Butt Weld    O Socket Weld    ● Threaded

Valve Size		ASME Class		
Inch	mm	150	300	600
.75	20	Δ O	Δ O	Δ O
1	25	Δ O ●	Δ O ●	Δ O ●
1.5	40	Δ O ●	Δ O ●	Δ O ●
2	50	Δ O ●	Δ O ●	Δ O ●
3	80	Δ ●	Δ ●	Δ ●
4	100	Δ	Δ	Δ
6	150	Δ	Δ	Δ
8	200	Δ	Δ	Δ
10	250	Δ	Δ	Δ
12	300	Δ	Δ	Δ
14	350	Δ	Δ	Δ
16	400	Δ	Δ	Δ

Note: Consult factory for availability of additional sizes and end connections.

## Flow Coefficient – Rated $C_v$

Nominal Size		Travel		Full Capacity $C_v^1$	Reduced Capacity $C_v$
Inch	mm	Inch	mm		
.75	20	0.5	12.7	8	-
1	25	0.5	12.7	12	8 <sup>2</sup>
1.5	40	0.8	20.3	28	11
2	50	0.8	20.3	48	19
3	80	1.5	38.1	110	44
4	100	1.5	38.1	195	78
6	150	2	50.8	450	180
8	200	2.5	63.5	750	300
10	250	2.5	63.5	1160	460
12	300	3.5	88.9	1620	650
14 <sup>3</sup>	350	4	101.6	2000 <sup>4</sup>	-
16	400	4	101.6	2560 <sup>4</sup>	-

1. Rated  $C_v$  for Quick Opening trim is 1.3 times values shown.
2. 1" size reduced capacity trim is same as .75" size full area trim.
3. Consult factory for details on 14" size.
4. 14" and 16" sizes are only available with Equal Percentage trim.

# C<sub>V</sub> and F<sub>L</sub> Versus Travel

Contoured Trim  
ASME Class 150 to 600

Flow Characteristic: LINEAR

Percent of Travel			10	20	30	40	50	60	70	80	90	100
F <sub>L</sub>	Full Area		.63	.64	.65	.70	.77	.85	.90	.90	.89	.88
	Reduced Area		.63	.64	.65	.70	.75	.80	.82	.82	.81	.80
Valve Size	Orifice Diameter	Travel	Rated C <sub>v</sub>									
inch	inch	inch										
0.75	.88/.80	0.5	.8	1.6	2.4	3.2	4.0	4.8	5.6	6.4	7.2	8
1	.88/.80	0.5	.8	1.6	2.4	3.2	4.0	4.8	5.6	6.4	7.2	8
	1.06/.98	0.5	1.2	2.4	3.6	4.8	6	7.2	8.4	9.6	10.8	12
1.5	1.06/.98	0.8	1.1	2.2	3.3	4.4	5.5	6.6	7.7	8.8	9.9	11
	1.5/1.42	0.8	2.8	5.6	8.4	11.2	14	16.8	19.6	22.4	25.2	28
2	1.43/1.35	0.8	1.9	3.8	5.7	7.6	9.5	11.4	13.3	15.2	17.1	19
	2.00/1.90	0.8	4.8	9.6	14.4	19.2	24	28.8	33.6	38.4	43.2	48
3	1.87/1.78	1.5	4.4	8.8	13.2	17.6	22	26.4	30.8	35.2	39.6	44
	2.62/2.53	1.5	11	22	33	44	55	66	77	88	99	110
4	2.37/2.28	1.5	7.8	15.6	23.4	31.2	39	46.8	54.6	62.4	70.2	78
	3.50/3.40	1.5	19.5	39	58.5	78	97.5	117	136	156	175	195
6	3.50/3.40	2	18	36	54	72	90	108	126	144	162	180
	5.25/5.15	2	45	90	135	180	225	270	315	360	405	450
8	4.62/4.53	2.5	30	60	90	120	150	180	210	240	270	300
	7.00/6.87	2.5	75	150	225	300	375	450	525	600	675	750
10	5.25/5.15	2.5	46	92	138	184	230	276	322	368	414	460
	8.75/8.62	2.5	116	232	348	464	580	696	812	928	1044	1160
12	6.37/6.25	3.5	65	130	195	260	325	390	455	520	585	650
	10.50/10.34	3.5	162	324	486	648	810	972	1134	1295	1458	1620

# C<sub>V</sub> and F<sub>L</sub> Versus Travel

V-Port Trim  
ASME Class 150 to 600

Flow Characteristic: EQUAL PERCENTAGE

Percent of Travel			10	20	30	40	50	60	70	80	90	100
F <sub>L</sub>	Full Area		.96	.96	.96	.96	.95	.94	.94	.93	.91	.90
	Reduced Area		.96	.96	.95	.94	.93	.92	.91	.90	.89	.88
Valve Size	Orifice Diameter	Travel	Rated C <sub>v</sub>									
inch	inch	inch										
0.75	.88/.80	0.5	.24	.48	.64	.88	1.2	1.8	2.3	3.6	5.2	8
1	.88/.80	0.5	.24	.48	.64	.88	1.2	1.8	2.3	3.6	5.2	8
	1.06/.98	0.5	.36	.72	.96	1.3	1.8	2.6	3.5	5.4	7.8	12
1.5	1.06/.98	0.8	.33	.66	.88	1.2	1.6	2.4	3.2	4.9	7.1	11
	1.5/1.42	0.8	.84	1.7	2.2	3.1	4.2	6.2	8.1	12.6	18.2	28
2	1.43/1.35	0.8	0.6	1.1	1.5	2	2.8	4.2	5.5	8.5	12.3	19
	2.00/1.90	0.8	1.4	2.8	3.8	5.3	7.2	10.5	13.9	21.6	31.2	48
3	1.87/1.78	1.5	1.3	2.6	3.5	4.8	6.6	9.7	12.8	19.8	28.6	44
	2.62/2.53	1.5	3.3	6.6	8.8	12.1	16.5	24.2	31.9	49.5	71.5	110
4	2.37/2.28	1.5	2.3	4.7	6.2	8.6	11.7	17.2	22.6	35.1	50.7	78
	3.50/3.40	1.5	5.8	11.7	15.6	21.4	29.2	42.9	56.5	87.7	126	195
6	3.50/3.40	2	5	11	14	20	27	40	52	81	117	180
	5.25/5.15	2	14	27	36	50	68	99	130	202	292	450
8	4.62/4.53	2.5	9	18	24	33	45	66	87	135	195	300
	7.00/6.87	2.5	23	45	60	83	112	165	217	337	487	750
10	5.25/5.15	2.5	14	28	37	51	69	101	133	207	299	460
	8.75/8.62	2.5	35	70	93	127	174	255	336	522	754	1160
12	6.37/6.25	3.5	20	39	52	72	98	143	189	293	423	650
	10.50/10.34	3.5	49	97	130	178	243	356	469	729	1053	1620
16	14.00/13.86	4	77	153	207	281	384	563	742	1152	1664	2560

# Materials of Construction

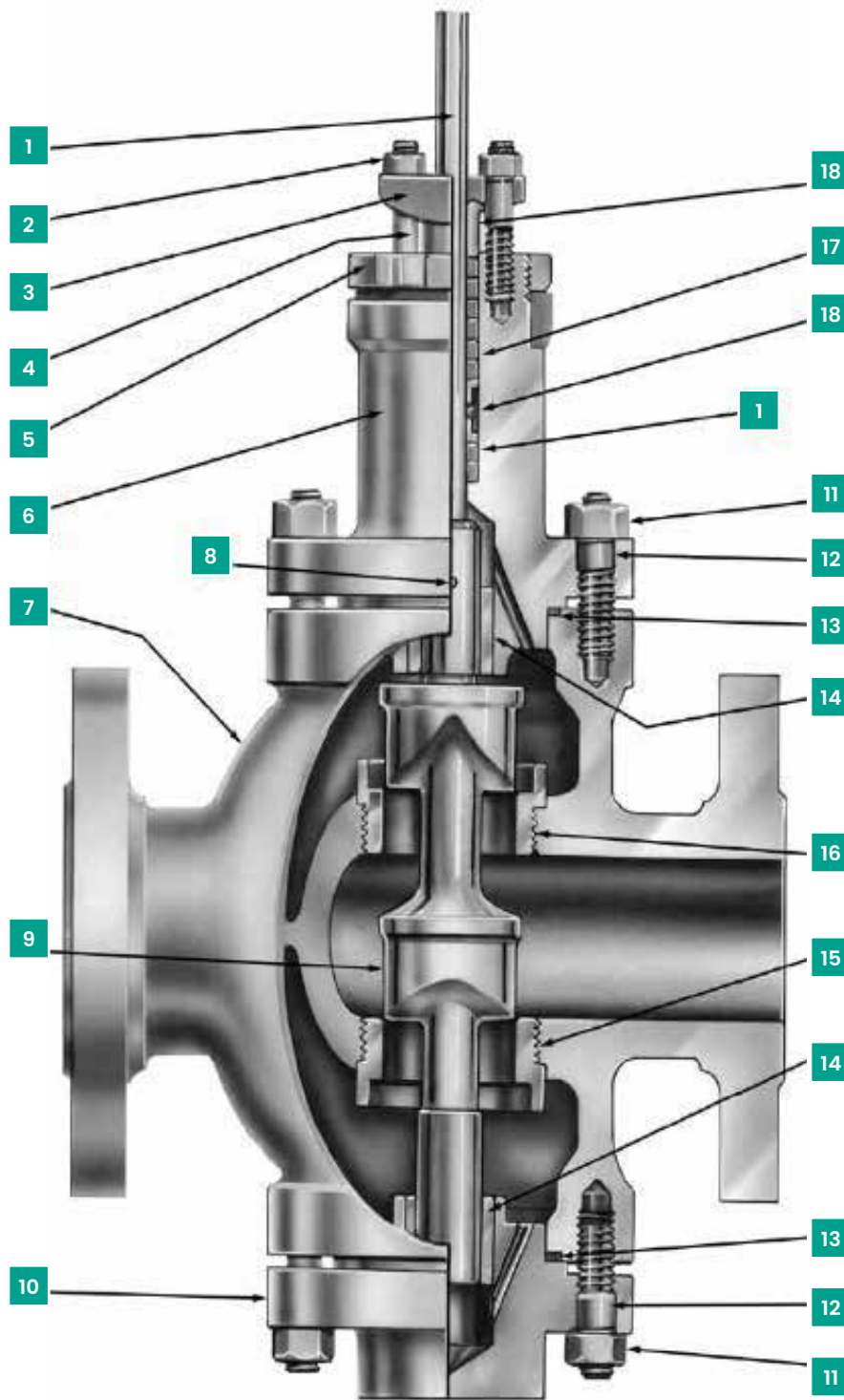

# Materials of Construction

## Standard Carbon Steel Version

Ref. No.	Temperature Rating	-20°F	650°F	800°F
	Description	Materials		
1	Plug Stem	316 St. St. ASTM 479 TY 316		
2	Packing Flange Nut	St. St. ASTM A194 GR 8		
3	Packing Flange	Zinc Dichromate Carbon Steel ASTM A105		
4	Packing Flange Stud	304 St. St. ASTM A193 GR B8		
5	Drive Nut	Carbon Steel SAE 1117 or ASTM A216 GR WCC		
6	Valve Bonnet	Carbon Steel ASTM A216 Grade WCC or ASTM A105		
7	Valve Body	Carbon Steel ASTM A216 Grade WCC		
8	Plug Pin	316 St. St. ASTM 479 TY 316		
9	Plug	316 St. St. ASTM 479 TY 316	316 St. St. with Hardfaced Seat and Guide	
		316 St.St.with Hardfaced Seat		
10	Lower Flange	Carbon Steel ASTM A216 Grade WCC or ASTM A105		
11	Body Stud Nut	Carbon Steel ASTM A194 GR 2H		
12	Body Stud	Alloy Steel ASTM A193 GR B7		
13	Body Gasket	316L St. St. w/Flexible Graphite Filler (Spiral Wound)		
14	Guide Bushing	440C St. St. ASTM A276 TY 440C	Stellite or Equivalent 6 UNS 30006	
15	Lower Seat Ring	316 St. St. ASTM 479 TY 316	316 St. St. with Hardfaced Seat	
		316 St.St. with Hardfaced Seat		
16	Upper Seat Ring	316 St. St. ASTM 479 TY 316	316 St. St. with Hardfaced Seat	
		316 St.St. with Hardfaced Seat		
18	Lantern Ring (Optional)	Austenitic 300 Series Stainless Steel		
19	Packing Follower	Austenitic 300 Series Stainless Steel		
Ref. No.	Temperature Range	-29°C	343°C	427°C



# Materials of Construction

## Standard Stainless Version

Ref. No.	Temperature Rating	-148°F	-20°F	650°F	800°F	
		Description	Materials			
1		Plug Stem				316 St. St. ASTM 479 TY 316
2		Packing Flange Nut				St. St. ASTM A194 GR 8
3		Packing Flange				Zinc Dichromate Carbon Steel ASTM A105
4		Packing Flange Stud				304 St. St. ASTM A193 GR B8
5		Drive Nut				Carbon Steel SAE 1117 or ASTM A216 GR WCC
6		Valve Bonnet Plain Version		316 Stainless Steel ASTM A351 Grade CF8M or ASTM A182 Grade F316		
6		Valve Bonnet Extended Version				316 Stainless Steel ASTM A351 Grade CF8M or ASTM A182 Grade F316
7		Valve Body				316 Stainless Steel ASTM A351 Grade CF8M
8		Plug Pin				316 St. St. ASTM 479 TY 316
9		Plug			316 St. St. with Hardfaced Seat and Guide	
		316 St. St. ASTM 479 TY 316				
9		316 St.St. with Hardfaced Seat			316 St. St. with Hardfaced Seat and Guide	
		316 St. St. ASTM 479 TY 316				
10		Lower Flange				316 Stainless Steel ASTM A351 Grade CF8M or ASTM A182 Grade F316
11		Body Stud Nut		Carbon Steel ASTM A194 GR 2H Zinc Dichromate Plating	C. S. ASTM A194 GR 2H (No Zinc)	
		ASTM A194 Gr. 8				
12		Body Stud		Alloy Steel ASTM A193 GR B7 Zinc Dichromate Plating	Alloy Steel ASTM A193 GR B7 <sup>3</sup>	
		ASTM A193 Gr. B8 <sup>3</sup>				
13		Body Gasket				316L St. St. w/Flexible Graphite Filler (Spiral Wound)
14		Guide Bushing				Stellite or Equivalent 6 <sup>2</sup>
15		Lower Seat Ring			316 St. St. with Hardfaced Seat	
		316 St. St. ASTM 479 TY 316				
15		316 St.St. with Hardfaced Seat			316 St. St. with Hardfaced Seat	
		316 St. St. ASTM 479 TY 316				
16		Upper Seat Ring			316 St. St. with Hardfaced Seat	
		316 St.St. with Hardfaced Seat				
18		Lantern Ring (Optional)				Austenitic 300 Series Stainless Steel
19		Packing Follower				Austenitic 300 Series Stainless Steel
Ref. No.	Temperature Range	-100°C	-29°C	343°C	427°C	

1. Use of non-plated bolting must be reviewed by the factory for proper application.

2. For operating temperatures above 650°F (343°C), the Solid Stellite or Equivalent bushings are tack welded to the bonnet and lower flange to account for thermal expansion.

3. ASTM A453 Gr. 660 may be required to meet low temperature or corrosion resistance requirements.

# Materials of Construction

## Standard Chrome-Moly Version

Ref. No.	Temperature Rating		32°F	650°F	800°F
	Description		Materials		
1	Plug Stem		316 St. St. ASTM 479 TY 316		
2	Packing Flange Nut		St. St. ASTM A194 GR 8		
3	Packing Flange		Zinc Dichromate Carbon Steel ASTM A105		
4	Packing Flange Stud		304 St. St. ASTM A193 GR B8		
5	Drive Nut		Carbon Steel SAE 1117 or ASTM A216 GR WCC		
6	Valve Bonnet		Chrome-Molybdenum Steel ASTM A217 Grade WC9		
7	Valve Body		Chrome-Molybdenum Steel ASTM A217 Grade WC9		
8	Plug Pin		316 St. St. ASTM 479 TY 316		
9	Plug		316 St. St. ASTM 479 TY 316	316 St. St. with Hardfaced Seat and Guide	
			316 St.St.with Hardfaced Seat		
10	Lower Flange		Chrome-Molybdenum Steel ASTM A217 Grade WC9		
11	Body Stud Nut		Carbon Steel ASTM A194 GR 2H		
12	Body Stud		Alloy Steel ASTM A193 GR B7		
13	Body Gasket		316L St. St. w/Flexible Graphite Filler (Spiral Wound)		
14	Guide Bushing		440C St. St. ASTM A276 TY 440C	Stellite or Equivalent 6 UNS 30006	
15	Lower Seat Ring		316 St. St. ASTM 479 TY 316	316 St. St. with Hardfaced Seat	
			316 St.St. with Hardfaced Seat		
16	Upper Seat Ring		316 St. St. ASTM 479 TY 316	316 St. St. with Hardfaced Seat	
			316 St.St. with Hardfaced Seat		
18	Lantern Ring (Optional)		Austenitic 300 Series Stainless Steel		
19	Packing Follower		Austenitic 300 Series Stainless Steel		
Ref. No.	Temperature Range		0°C	343°C	427°C

## Packing Options - Carbon Steel, Stainless Steel and Chrome-Moly Constructions

Ref. No.	Temperature Rating		-20°F	450°F	800°F
	Description		Materials		
17	Packing	Standard Bonnet	PTFE Packing		
			Low-E Packing		
			Expanded Graphite Filler + Graphite wiper rings		
	Packing	Extension Bonnet	PTFE Packing		
Low-E Packing					
Ref. No.	Temperature Range		-29°C	232°C	427°C

# Materials of Construction

## NACE Materials Construction

Ref. No.	Temperature Range	-20°F	450°F
	Description	Standard and Optional Materials	
1	Plug Stem	316 St. St. ASTM A479 TY 316 (HRC 22 Max.)	
		ASTM A638 Gr 660 <sup>2</sup>	
2	Packing Flange Nut	304 St. St. ASTM A194 Gr 8 <sup>3</sup> (non exposed)	
		Alloy Steel ASTM A194 Gr 8A <sup>4</sup> (exposed)	
3	Packing Flange	Zinc Dichromate Carbon Steel ASTM A105	
4	Packing Flange Stud	304 St. St. ASTM A193 GR B8 (exposed and non exposed)	
5	Drive Nut	Carbon Steel ASTM A105 or SAE 1010-1025 <sup>5</sup>	
6	Valve Bonnet	Carbon Steel ASTM A216 Grade WCC (HRC 22 Max.)	
		Carbon Steel ASTM A105 (HRC 22 Max.)	
		316 St. St. ASTM A351 Gr CF8M (HRC 22 Max.)	
7	Valve Body	Carbon Steel ASTM A216 Grade WCC (HRC 22 Max.)	
		316 St. St. ASTM A351 Gr CF8M (HRC 22 Max.)	
8	Plug Pin	316 St. St. ASTM A479 TY 316 (HRC 22 Max.)	
9	Plug	316 St. St. ASTM A479 TY 316 (HRC 22 Max.)	
		316 St. St. ASTM A479 TY 316 with Hardfaced Seat (HRC 22 Max.)	
10	Lower Flange	Carbon Steel ASTM A216 Grade WCC (HRC 22 Max.)	
		Carbon Steel ASTM A105 (HRC 22 Max.)	
		316 St. St. ASTM A351 Gr CF8M (HRC 22 Max.)	
11	Body Stud Nut	ASTM A194 GR 2H <sup>3</sup> (non exposed)	
		ASTM A194 Gr 2HM <sup>4</sup> (exposed)	
		ASTM A194 GR 2H Zinc Plating <sup>3 &amp; 5</sup> (non exposed)	
		ASTM A194 Gr 2HM Zinc Plating <sup>4 &amp; 5</sup> (exposed)	
12	Body Stud	ASTM A193 GR B7 <sup>3</sup> (non exposed)	
		ASTM A193 Gr B7M <sup>4</sup> (exposed)	
		ASTM A193 GR B7 Zinc Plated <sup>3 &amp; 5</sup> (non exposed)	
		ASTM A193 Gr B7M Zinc Plated <sup>4 &amp; 5</sup> (exposed)	
13	Body Gasket	316L St. St. w/Flexible Graphite Filler (Spiral Wound)	
14	Guide Bushing	Stellite or Equivalent 6 UNS 30006	
Ref. No.	Temperature Range	-29°C	232°C

# Materials of Construction

## NACE Materials Construction

Ref. No.	Temperature Range	-20°F	450°F
Ref. No.	Description	Standard and Optional Materials	
15	Lower Seat Ring	316 St. St. ASTM A479 TY 316 (HRC 22 Max.)	
		316 St. St. ASTM A479 TY 316 with Hardfaced Seat (HRC 22 Max.)	
16	Upper Seat Ring	316 St. St. ASTM A479 TY 316 (HRC 22 Max.)	
		316 St. St. ASTM A479 TY 316 with Hardfaced Seat (HRC 22 Max.)	
17	Packing	PTFE Packing	
18	Lantern Ring (Optional)	304 St. St. ASTM A479 TY 304	
19	Packing Follower	304 St. St. ASTM A479 TY 304	
Ref. No.	Temperature Range	-29°C	232°C

1. Materials and processes in accordance with the requirements of NACE specification MR0103, 2003. Applications requiring compliance to MR0175, 2003 Rev. or ISO 15156 would require engineering review.
2. ASTM A638 Gr 660 will be substituted in applications when required due to the differential pressure.
3. Materials designated for these parts conform to NACE Class III (unexposed) bolting requirements.
4. Materials designated for these parts conform to NACE Class I or Class II (exposed) bolting requirement.
5. Zinc plating is mandatory for St. Steel construction only.

# Valve Dimensions

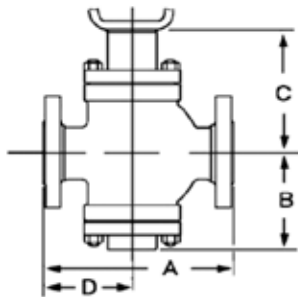

Flanged Ends

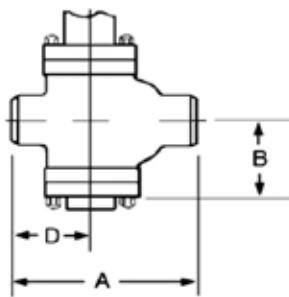

Socket Weld  
or Threaded Ends

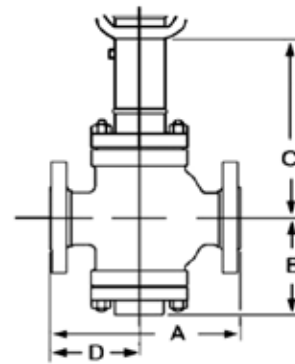

Extension Bonnet

## 10000 Series Dimensions (inches)

Valve Size		ASME Class 150 and equivalent PN				ASME Class 300 and equivalent PN				ASME Class 600 and equivalent PN				ASME Class 150-600 and equivalent PN	
inches	mm	RF		RTJ		RF		RTJ		RF		RTJ		Threaded & Socket Weld	
		A	D	A	D	A	D	A	D	A	D	A	D	A	D
0.75	20	7.24	3.66	-	-	7.64	3.86	8.11	4.09	8.11	4.09	8.11	4.09	6.02	2.87
1	25	7.24	3.66	7.76	3.90	7.76	3.90	8.27	4.13	8.27	4.13	8.27	4.13	6.02	2.87
1.5	40	8.74	4.09	9.25	4.33	9.25	4.33	9.76	4.57	9.88	4.65	9.88	4.65	7.99	3.70
2	50	10.00	4.61	10.51	4.88	10.51	4.88	11.10	5.20	11.26	5.24	11.38	5.31	9.25	4.13
3	80	11.73	5.51	12.24	5.75	12.52	5.87	13.11	6.18	13.27	6.26	13.39	6.30	-	-
4	100	13.90	6.57	14.37	6.81	14.49	6.89	15.12	7.20	15.51	7.36	15.63	7.44	-	-
6	150	17.76	7.64	18.11	7.87	18.62	8.08	19.25	8.39	20.00	8.74	20.12	8.82	-	-
8	200	21.38	8.54	21.89	8.82	22.40	9.06	22.99	9.37	24.02	9.88	24.13	9.92	-	-
10	250	24.61	9.96	25.12	10.24	26.02	10.67	26.65	10.98	27.75	11.54	27.87	11.61	-	-
12	300	28.74	11.30	29.25	11.57	30.24	12.09	30.87	12.36	32.01	12.91	32.13	12.99	-	-
16	400	35.39	15.71	35.87	15.94	37.01	16.50	37.64	16.81	39.02	17.24	39.13	17.32	-	-

Valve Size		ASME Class 150 - 600 and equivalent PN		
inches	mm	8	C (Std. Bonnet)	C (EB Bonnet)
0.75	20	4.49	5.67	9.72
1	25	4.49	5.67	9.72
1.5	40	5.39	6.02	10.67
2	50	5.98	7.20	11.42
3	80	7.80	9.29	13.11
4	100	8.11	9.49	13.74
6	150	11.18	12.60	18.03
8	200	13.39	14.69	20.00
10	250	14.80	16.42	22.60
12	300	17.80	19.80	25.98
16	400	22.28	26.10	34.61

# Valve Dimensions

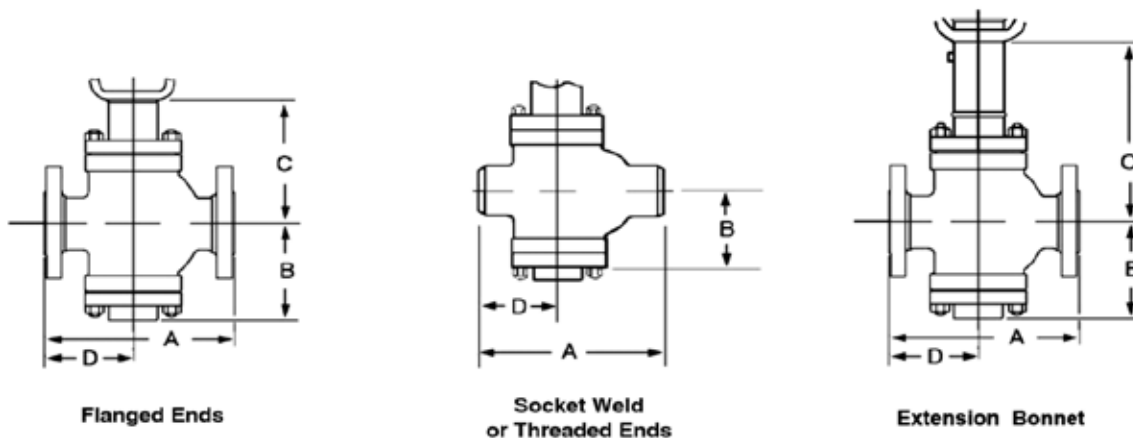

## 10000 Series Dimensions (mm)

Valve Size		ASME Class 150 and equivalent PN				ASME Class 300 and equivalent PN				ASME Class 600 and equivalent PN				ASME Class 150-600 and equivalent PN	
mm	inches	RF		RTJ		RF		RTJ		RF		RTJ		Threaded & Socket Weld	
		A	D	A	D	A	D	A	D	A	D	A	D	A	D
20	0.75	184	93	-	-	194	98	206	104	206	104	206	104	153	73
25	1	184	93	197	99	197	99	210	105	210	105	210	105	153	73
40	1.5	222	104	235	110	235	110	248	116	251	118	251	118	203	94
50	2	254	117	267	124	267	124	282	132	286	133	289	135	235	105
80	3	298	140	311	146	318	149	333	157	337	159	340	160	-	-
100	4	353	167	365	173	368	175	384	183	394	187	397	189	-	-
150	6	451	194	460	200	473	205	489	213	508	222	511	224	-	-
200	8	543	217	556	224	589	230	584	238	610	251	613	252	-	-
250	10	625	253	638	260	661	271	677	279	705	298	708	295	-	-
300	12	730	287	743	294	768	307	784	314	813	328	816	330	-	-
400	16	899	399	911	405	940	419	956	427	991	438	994	440	-	-

Valve Size		ASME Class 150 – 600 and equivalent PN		
mm	inches	8	C (Std. Bonnet)	C (EB Bonnet)
20	0.75	114	144	247
25	1	114	144	247
40	1.5	137	153	271
50	2	152	183	290
80	3	198	236	333
100	4	206	241	349
150	6	284	320	458
200	8	340	373	508
250	10	376	417	574
300	12	452	503	660
400	16	566	663	879

# Valve Weights

## Weights in (lbs)

Valve Size		ASME Class 150-600 and equivalent PN	ASME Class 150 and equivalent PN	ASME Class 300 and equivalent PN	ASME Class 600 and equivalent PN
inches	mm	Threaded & Socket Weld	Flanged		
0.75	20	40	79	79	90
1	25	44	86	86	99
1.5	40	44	106	110	119
2	50	51	150	159	174
3	80	110	245	256	269
4	100	192	304	309	335
6	150	364	514	529	595
8	200	668	798	825	959
10	250	1168	1349	1378	1497
12	300	1455	1698	1737	1898
16	400	2579	3016	3086	4198

1. Consult factory for weight data on 14" size.

## Weights in (kg)

Valve Size		ASME Class 150-600 and equivalent PN	ASME Class 150 and equivalent PN	ASME Class 300 and equivalent PN	ASME Class 600 and equivalent PN
mm	inches	Threaded & Socket Weld	Flanged		
20	0.75	18	36	36	41
25	1	20	39	39	45
40	1.5	20	48	50	54
50	2	23	68	72	79
80	3	50	111	116	122
100	4	87	138	140	152
150	6	165	233	240	270
200	8	303	362	374	435
250	10	530	612	625	679
300	12	660	770	788	861
400	16	1170	1368	1400	1904

1. Consult factory for weight data on 14" size.

# Actuator Dimensions and Weights (in./lbs)

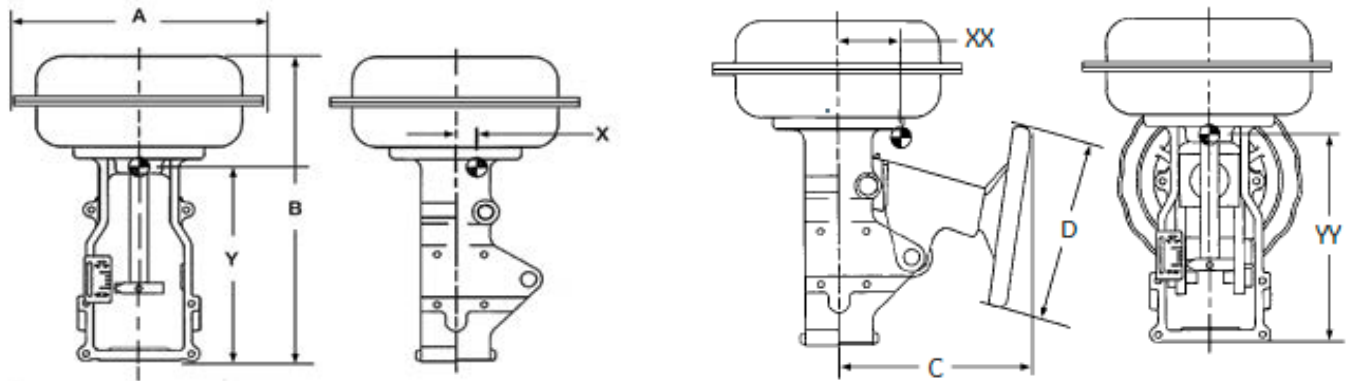

Shown with optional Handwheel

## Dimensions and Weight

Actuator Size	Actuator Dimensions (inches)				Weights (lbs.)	
	A	B (Model 88)	C	D	Standard	w/Handwheel
6	11.50	15.54 (17.52)	10.00	9.00	45	60
10	14.50	19.58 (21.54)	10.90	12.00	85	105
16	18.75	28.22 (30.79)	14.00	18.00	210	245
23	21.63	30.71 (33.27)	16.00	18.00	265	320

Actuator Removal Clearance = 6 inches

## Center of Gravity (inches) Without Handwheel

Size	X	Y
6	.19	9.75
10	.0	12.88
16	.13	18.50
23	.06	21.13

## Center of Gravity (inches) With Handwheel

Size	XX	YY
6	1.25	9.13
10	0.88	12.00
16	1.38	16.75
23	1.38	19.00

## Limit Stops (inches) Up Stop

Size	Model	Overall Height B
6	87	19.45
10		25.43
16		36.42
23		38.84
6	88	19.16
10		25.06
16		35.48
23		38.65

## Down Stop

Size	Model	Overall Height B
6	87	19.80
10		25.98
16		37.20
23		39.90
6	88	19.74
10		25.85
16		37.46
23		40.33



# Actuator Dimensions and Weights (mm/kg)

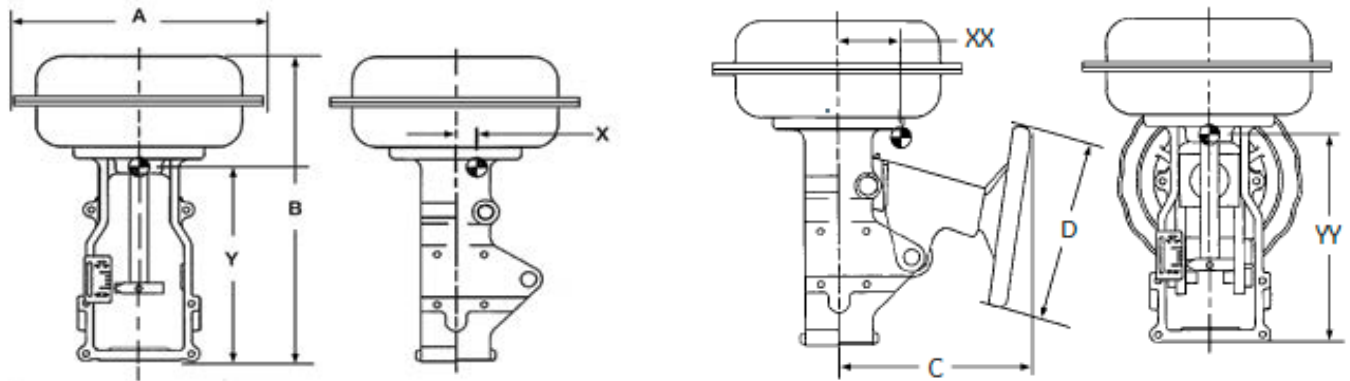

Shown with optional Handwheel

## Dimensions and Weight

Actuator Size	Actuator Dimensions (mm)				Weights (kg)	
	A	B (Model 88)	C	D	Standard	w/Handwheel
6	302	395 (445)	254	229	20	27
10	373	497 (547)	277	305	39	48
16	476	717 (782)	356	457	95	111
23	549	780 (845)	406	457	120	145

Actuator Removal Clearance = 152mm

## Center of Gravity (mm) Without Handwheel

Size	X	Y
6	5	248
10	0	327
16	3	470
23	2	537

## Center of Gravity (mm) With Handwheel

Size	XX	YY
6	32	232
10	22	305
16	35	425
23	35	483

## Limit Stops (mm) Up Stop

Size	Model	Overall Height B
6	87	494
10		646
16		925
23		987
6	88	487
10		636
16		901
23		982

## Down Stop

Size	Model	Overall Height B
6	87	503
10		660
16		945
23		1014
6	88	501
10		657
16		952
23		1024







CONTROLS SUPPLY CHAIN

VALVES ACTUATORS INSTRUMENTATIONS