

# Masoneilan™ 173 Series

Spring Loaded, Direct Operated  
Back-Pressure Regulator



# Table of contents

Numbering System.....3

Features/Specifications .....4

Construction Actuator Size 220.....5

Construction Actuator Sizes 100 to 140 .....6

Dimensions .....7

Set Pressure Ranges .....8

Standard Material Combinations.....9

Capacity Ranges.....10

Temperature Ranges for Disc Elastomers.....10

Temperature Ranges for Diaphragms.....10

Weights .....11

## Numbering System

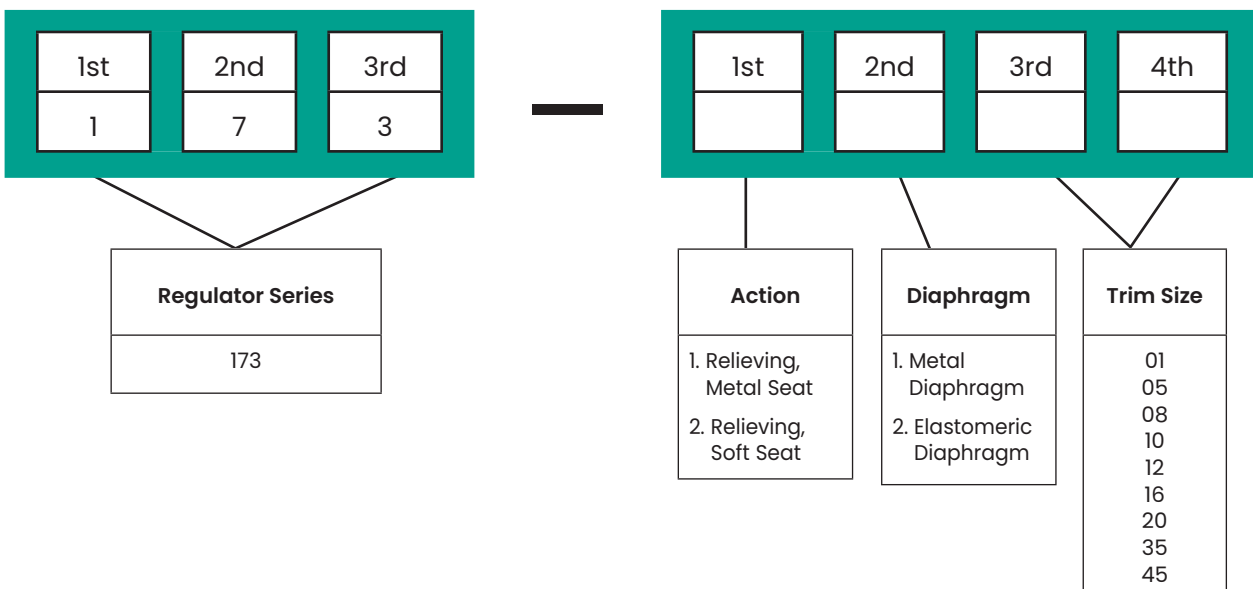

# 173 Series

## Threaded or Flanged Connections Carbon Steel, Stainless Steel & Alloy Constructions

The 173 Series are direct operated, pressure relieving or back pressure regulators designed for steam, gas and liquid services. Available in body sizes 1/2" through 2" (DN15 through DN50) in a variety of end connections to suit most applications. These regulators are designed for continuous, rugged industrial use to provide years of reliable service.

## Features

- Versatility
- In-line maintenance
- High stability
- Rugged construction

## Specifications

### Body

- Body Sizes and End Connections
  - see table 1
- Standard Set Pressure Ranges:
  - see table 2
- Set Point Range:
  - .017 to 667 psig (0.0012 to 46.0 barg) – see table 2
- Temperature Range:
  - see tables 3, 5, 6
- Pressure Sensing:
  - internal (external on request)
- Capacities:
  - see table 4
- Weight:
  - see tables 7 thru 10

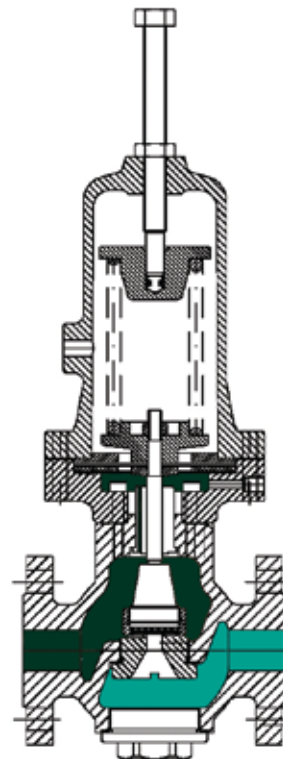

# Construction

## Actuator Size 220

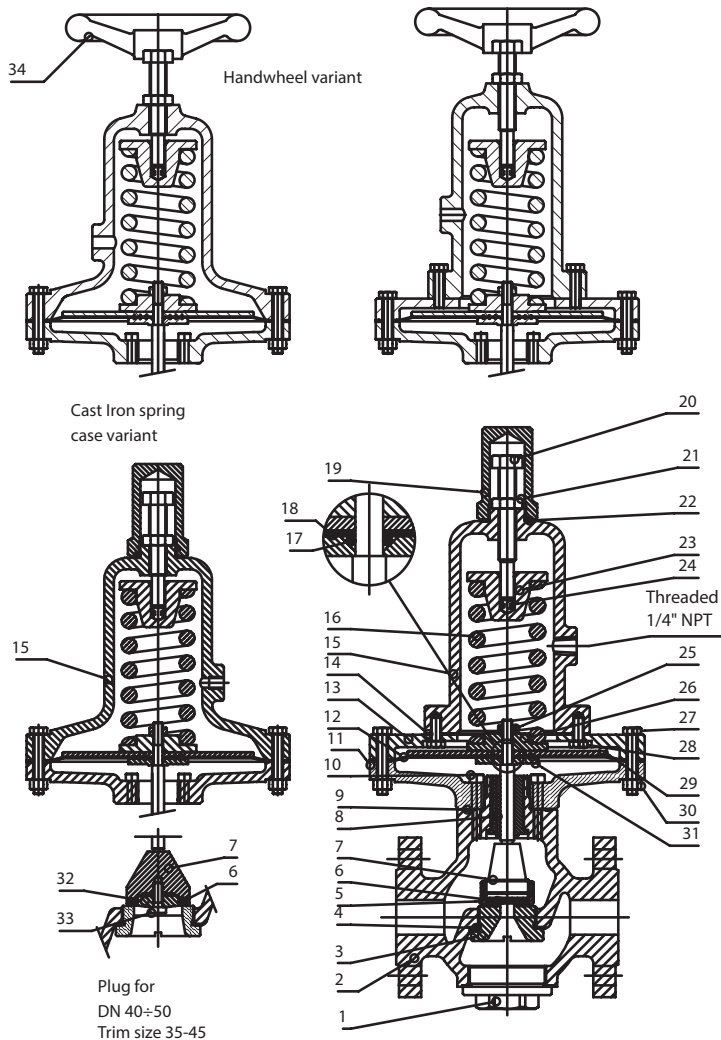

Materials			
1	Blindhead	18	Protector (Optional)
2	Body	19	Cap (Optional)
3	Seat	20	Adjusting Screw
4	Gasket	21	Adjusting Screw Locknut
5	Ring	22	Spring Button (Upper)
6	Plug Seal Elastomer	23	Spring Loader
7	Plug	24	Ball
8	Guide Bushing	25	Nut
9	Gasket	26	Spring Button (Lower)
10	Screw	27	Screw
11	Diaphragm Case	28	Screw
12	Diaphragm	29	Diaphragm Plate (Upper)
13	Actuator Upper Flange	30	Nut
14	Gasket	31	Diaphragm Plate (Lower)
15	Spring Case	32	Soft Seat Retainer
16	Spring	33	Plug Screw
17	O-Ring	34	Handwheel (Optional)

## Flanged Construction

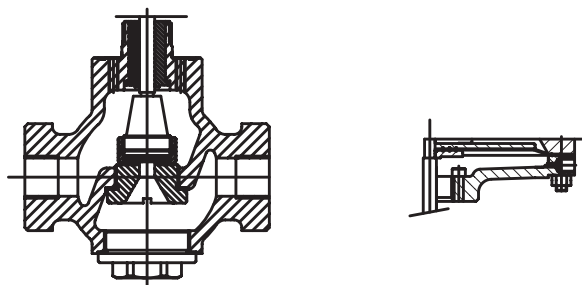

**Threaded Construction**

**External Pressure Sensing (Optional)**

# Construction

Actuator Sizes 100 to 140

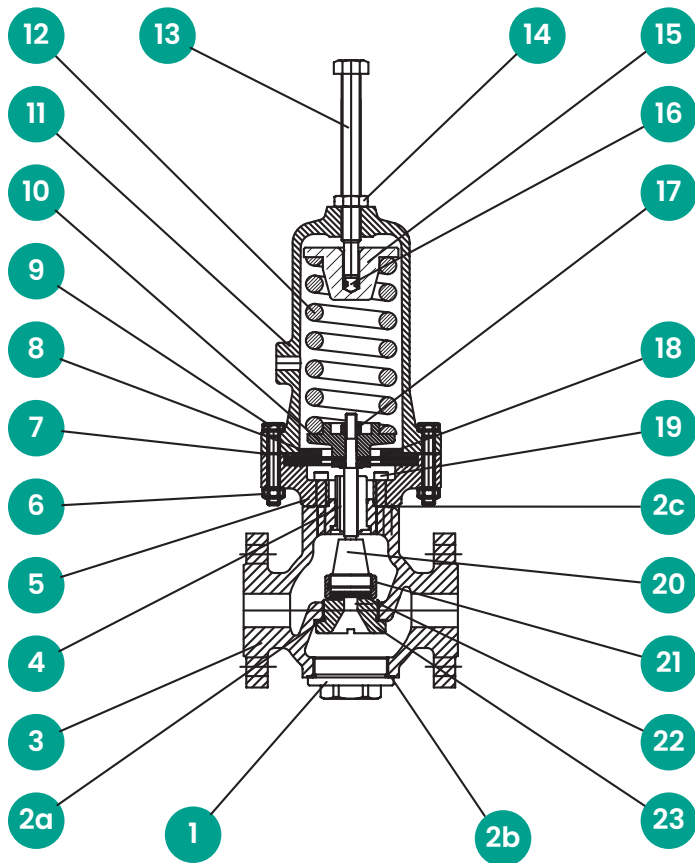

Materials			
1	Blindhead	13	Adjusting Screw
2	Gaskets	14	Adjusting Screw Locknut
3	Valve Body	15	Spring Button (Upper)
4	Guide	16	Ball
5	Diaphragm Case	17	Spring Button (Lower)
6	Nut	18	Diaphragm Plate (Upper)
7	Diaphragm Plate (Lower)	19	Screw
8	Diaphragm	20	Plug
9	Protector (Optional)	21	Plug Screw
10	O-Ring	22	Disc
11	Spring Case	23	Seat
12	Spring		

## Flanged Construction

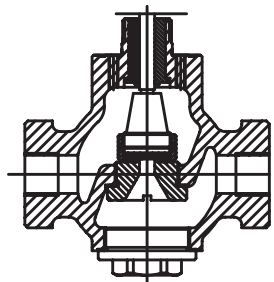

**Threaded Construction**

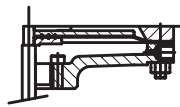

**External Pressure Sensing (Optional)**

# Dimensions

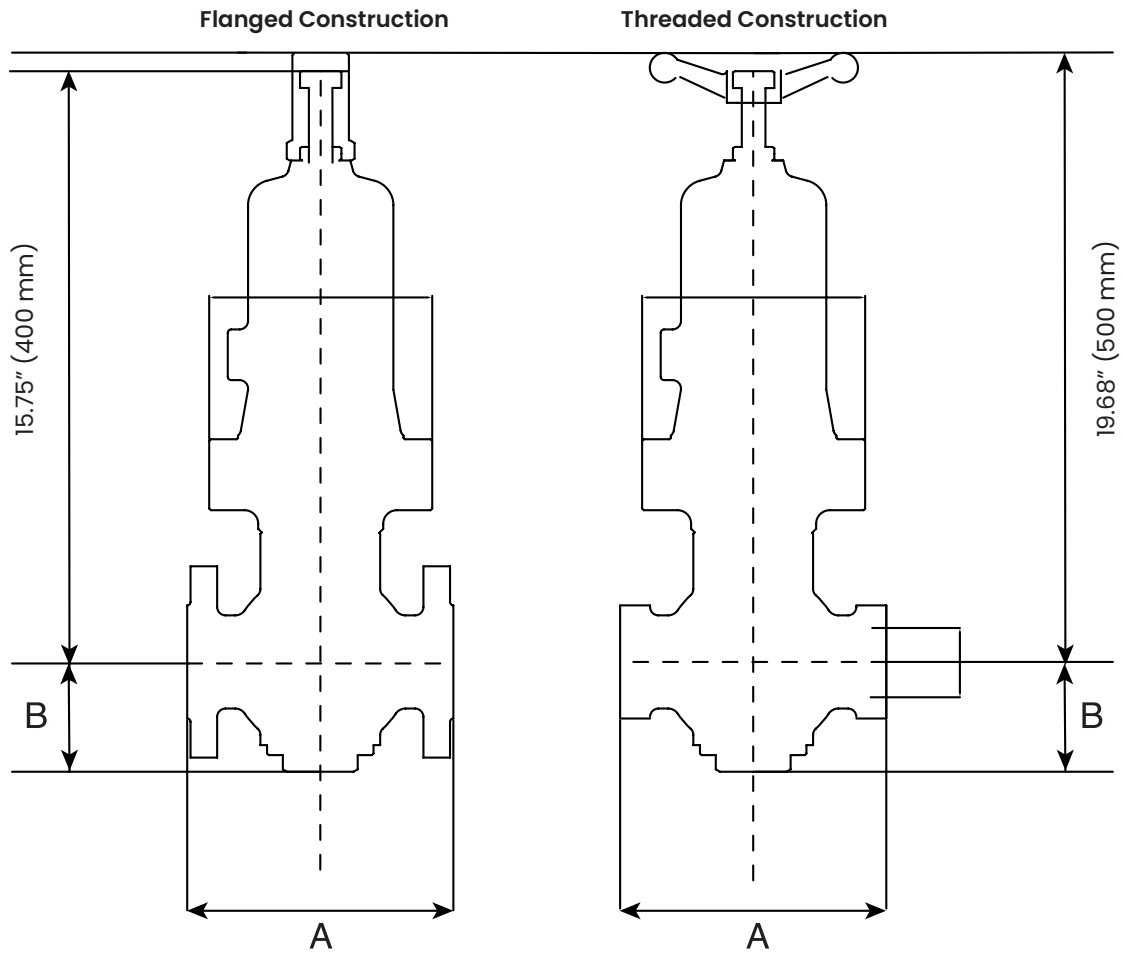

**Table 1 - Body Sizes and Face to Face Dimensions**

Size		ASME CL 150RF		ASME CL 300RF		ASME CL 600RF		Threaded	
								NPT-F	
								BSP-F	
								A	
in	DN	in	mm	in	mm	in	mm	in	mm
1/2"	DN15	7.25	184	7.5	190	8	203	5.12	130
3/4"	DN20	7.25	184	7.62	194	8.12	206	5.12	130
1"	DN25	7.25	184	7.75	197	8.25	210	5.12	130
1-1/2"	DN40	8.75	222	9.25	235	9.88	251	6.7	170
2"	DN50	10	254	10.5	267	11.25	286	6.7	170

# Set Pressure Ranges

**Table 2 – Standard Set Pressure Ranges**

Spring ranges are based on the following assumptions:

1. Stroke from setpoint is ±3mm
2. Offset max 20% for minimum set pressure
3. Low unbalancing forces on the plug

	Upright installation
	Upside down installation

Actuator	Spring	Spring Ranges				
		Min. Set Pressure		Max. Set Pressure		
	Name	barg	psig	barg	psig	
100	4BIS	4.5	65	8.7	126	
	6	7.2	105	14.0	203	
	7	10.4	151	21.6	314	
	8	14.6	211	23.0	334	
	9	22.0	319	34.6	502	
	9BIS	27.4	397	37.9	550	
	10	34.1	494	41.7	604	
	10BIS	37.8	548	46.0	667	
	120	4BIS	206	37	4.1	59
		6	3.8	56	6.6	95
7		5.3	77	10.1	147	
8		7.3	105	10.8	156	
9		10.8	156	16.2	235	
9BIS		13.3	193	17.8	258	
10		16.4	238	19.5	283	
10BIS		18.1	263	29.5	428	
130		4BIS	1.7	25	3.0	44
		6	2.7	39	4.9	71
	7	3.8	55	7.6	110	
	8	5.2	76	8.0	116	
	9	7.8	113	12.1	175	
	9BIS	9.7	141	13.2	192	
	10	12.0	174	14.5	211	
	10BIS	13.3	193	22.1	320	
	140	4BIS	0.7	10	1.3	19
		6	1.1	16	2.1	31
7		1.6	23	3.3	47	
8		2.2	32	3.5	50	
9		3.3	48	5.2	75	
9BIS		4.1	60	5.7	83	
10		5.1	74	6.3	91	
10BIS		5.7	82	9.2	133	
220		2BIS	0.094	1.36	0.12	1.8
		3	0.196	1.54	0.20	3.0
	4	0.127	1.84	0.24	3.4	
	4BIS	0.144	2.1	0.37	5.4	
	6	0.26	3.8	0.60	8.7	
	7	0.40	5.8	0.93	13.4	
	8	0.58	8.4	0.99	14.3	
	9	0.89	13	1.5	21.5	
	9BIS	1.1	16	1.6	23.6	
	10	1.4	20	1.8	25.9	
10BIS	1.6	23	2.7	38.7		
360	1 <sup>1</sup>	0.0025	0.036	0.014	0.21	
	1BIS	0.015	0.22	0.018	0.25	
	2BIS	0.019	0.27	0.039	0.56	
	3	0.023	0.33	0.063	0.92	
	4	0.029	0.42	0.073	1.1	
	4BIS	0.035	0.50	0.12	1.7	
	6	0.071	1.0	0.19	2.7	
	7	0.11	1.6	0.29	4.2	
	8	0.17	2.4	0.31	4.4	
	9	0.27	3.9	0.46	6.7	
9BIS	0.34	4.9	0.50	7.3		
10	0.43	6.2	0.55	8.0		
10BIS	0.48	6.9	0.84	12.2		
515	1 <sup>1</sup>	0.0012	0.017	0.0077	0.11	
	1BIS	0.0059	0.09	0.010	0.14	
	2BIS	0.0080	0.12	0.021	0.30	
	3	0.0100	0.15	0.034	0.50	
	4	0.014	0.20	0.04	0.6	
	4BIS	0.016	0.24	0.06	0.9	
	6	0.036	0.5	0.10	1.5	
	7	0.06	0.9	0.16	2.3	
	8	0.09	1.3	0.17	2.4	
	9	0.14	2.1	0.23	3.3	

1. Thin diaphragm (FKM 0.18mm) and upside down installation

# Materials

**Table 3 – Standard Material Combinations**

Body				
	Carbon Steel <sup>1</sup> 32°F < T < 392°F (0°C < T < 200°C)	Full Carbon Steel <sup>2</sup> -20°F < T < 392°F (-29°C < T < 200°C)	316 SS <sup>1</sup> -20°F < T < 392°F (-29°C < T < 200°C)	Full 316 SS <sup>2</sup> -320.8°F < T < 392°F (-196°C < T < 200°C)
Body	Carbon Steel	Carbon Steel	316 SS	316 SS
Blindhead	Carbon Steel	Carbon Steel	316 SS	316 SS
Gasket	P T F E	P T F E	P T F E	P T F E
Trim				
Seat	316 SS	316 SS	316 SS	316 SS
Disc	See table 6	See table 6	See table 6	See table 6
Plug Stem	316 SS	316 SS	316 SS	316 SS
Guide Bushing	304 SS / 17-4PH	304 SS / 17-4PH	304 SS / Nitronic 60	304 SS / Nitronic 60
Actuator				
Spring Case	Cast Iron	Carbon Steel	Carbon Steel	316 SS
Diaphragm Case	Carbon Steel	Carbon Steel	316 SS	316 SS
Spring	CrV Steel	CrV Steel	CrV Steel	316 SS
Diaphragm	See table 7			

Note: Special constructions are available in LCB, WCC (NACE), 316L, 317, Duplex, Superduplex, Monel, Hastelloy B/C

1. Standard – Except Steam Service

2. Non Standard – Manufactured on Request



# Capacity Ratings

**Table 4 – Rated  $C_v$  for All Body Sizes**

Trim Number	Body Size									
	1/2" (DN 15)		3/4" (DN 20)		1" (DN 25)		1 1/2" (DN 40)		2" (DN 25)	
1	0.033	0.031	0.033	0.031	0.033	0.031	0.033	0.031	0.033	0.031
5	0.60	0.20	0.60	0.20	0.60	0.20	0.60	0.20	0.60	0.20
8	1.7	0.33	1.7	0.33	1.7	0.33	1.7	0.33	1.7	0.33
10	2.5	0.40	2.5	0.40	2.5	0.40	2.5	0.40	2.5	0.40
12	3.4	0.50	3.4	0.50	3.4	0.50	3.4	0.50	3.4	0.50
16	–	–	6.5	0.9	6.5	0.9	7.0	0.9	7.0	0.9
20	–	–	–	–	8.7 (7.5)	1.4	9.0 (7.7)	1.4	9.0 (7.7)	1.4
35	–	–	–	–	–	–	19 (15)	3.0	19 (15)	3.0
45	–	–	–	–	–	–	–	–	35 (28)	5.5

1. Reduced  $C_v$  for Actuator 100



$C_v$  for all body sizes with elastomer diaphragm



$C_v$  for all body sizes with metal diaphragm

**Table 5 – Temperature Ranges for Disc Elastomers**

Material	min		max	
	°C	°F	°C	°F
fluorocarbon (FKM-FPM) <sup>1</sup>	-10	14	200	392
Polytetrafluoroethylene (PTFE) <sup>3</sup>	-200	-328	250	482
AISI 316 <sup>2</sup>	-196	-321	455	851

**Table 6 – Temperature Ranges for Diaphragms**

Material	T min		T max	
	°C	°F	°C	°F
Chloroprene (CR) <sup>1</sup>	-20	-4	90	194
Fluorocarbon (FKM-FPM) + polyester <sup>3</sup>	-10	14	150	302
Fluorocarbon (FKM-FPM) + polyarylamide <sup>3</sup>	-10	14	200	392
Ethylene-Propylene (EPDM) <sup>2</sup>	-35	-31	150	302
AISI 316 <sup>2</sup>	-196	-320.8	455	851

Note: Special diaphragms are available in NBR (nitrile butadiene, Buna-N or equivalent), HNBR (hydrogenated nitrile), VMQ (silicone), FVMQ (fluorosilicone), TFE/P (Aflas or equivalent)

1. Standard – Except Steam Service

2. Steam Service

3. Non Standard – Manufactured on Request

# Weights

**Table 7 – Weights – Actuator Sizes 100, 120, 130 & 140**

	NPT/GAS	Class 150 RF	PN 16/25/40	Class 300 RF	Class 600 RF
1/2" (DN15)	36.6 lbs (16.6 kg)	36.4 lbs (16.5 kg)	38.6 lbs (17.5 kg)	40.8 lbs (18.5 kg)	47.4 lbs (21.5 kg)
3/4" (DN20)	36.6 lbs (16.6 kg)	37.5 lbs (17.0 kg)	39.7 lbs (18.0 kg)	43.0 lbs (19.5 kg)	49.6 lbs (22.5 kg)
1" (DN25)	36.4 lbs (16.5 kg)	38.6 lbs (17.5 kg)	40.8 lbs (18.5 kg)	44.1 lbs (20.0 kg)	50.7 lbs (23.0 kg)
1 1/2" (DN40)	41.0 lbs (18.6 kg)	44.3 lbs (20.1 kg)	47.4 lbs (21.5 kg)	52.9 lbs (24.0 kg)	59.5 lbs (27.0 kg)
2" (DN50)	40.8 lbs (18.5 kg)	48.5 lbs (22.0 kg)	50.9 lbs (23.1 kg)	58.0 lbs (26.3 kg)	66.1 lbs (30.0 kg)

**Table 8 – Weights – Actuator Size 220**

	NPT/GAS	Class 150 RF	PN 16/25/40	Class 300 RF	Class 600 RF
1/2" (DN15)	41.0 lbs (18.6 kg)	40.8 lbs (18.5 kg)	43.0 lbs (19.5 kg)	45.2 lbs (20.5 kg)	51.8 lbs (23.5 kg)
3/4" (DN20)	41.0 lbs (18.6 kg)	41.9 lbs (19.0 kg)	44.1 lbs (20.0 kg)	47.4 lbs (21.5 kg)	54.0 lbs (24.5 kg)
1" (DN25)	40.8 lbs (18.5 kg)	43.0 lbs (19.5 kg)	45.2 lbs (20.5 kg)	48.5 lbs (22.0 kg)	57.3 lbs (26.0 kg)
1 1/2" (DN40)	45.4 lbs (20.6 kg)	48.7 lbs (22.1 kg)	51.8 lbs (23.5 kg)	57.3 lbs (26.0 kg)	64.0 lbs (29.0 kg)
2" (DN50)	45.2 lbs (20.5 kg)	52.9 lbs (24.0 kg)	55.3 lbs (25.1 kg)	62.4 lbs (28.3 kg)	68.3 lbs (31.0 kg)

**Table 9 – Weights – Actuator Size 360**

	NPT/GAS	Class 150 RF	PN 16/25/40	Class 300 RF	Class 600 RF
1/2" (DN15)	73.9 lbs (33.5 kg)	73.6 lbs (33.4 kg)	75.8 lbs (34.4 kg)	78.0 lbs (35.4 kg)	84.6 lbs (38.4 kg)
3/4" (DN20)	73.9 lbs (33.5 kg)	74.7 lbs (33.9 kg)	76.9 lbs (34.9 kg)	80.3 lbs (36.4 kg)	86.9 lbs (39.4 kg)
1" (DN25)	73.6 lbs (33.4 kg)	75.8 lbs (34.4 kg)	78.0 lbs (35.4 kg)	81.4 lbs (36.9 kg)	88.2 lbs (40.0 kg)
1 1/2" (DN40)	78.3 lbs (35.5 kg)	81.6 lbs (37.0 kg)	84.7 lbs (38.4 kg)	92.2 lbs (40.9 kg)	96.8 lbs (43.9 kg)
2" (DN50)	78.0 lbs (35.4 kg)	88.2 lbs (39.8 kg)	88.2 lbs (40.0 kg)	95.2 lbs (43.2 kg)	101.8 lbs (46.2 kg)

**Table 10 – Weights – Actuator Size 515**

	NPT/GAS	Class 150 RF	PN 16/25/40	Class 300 RF	Class 600 RF
1/2" (DN15)	52.5 lbs (23.8 kg)	52.3 lbs (23.7 kg)	54.5 lbs (24.7 kg)	56.7 lbs (25.7 kg)	63.3 lbs (28.7 kg)
3/4" (DN20)	52.5 lbs (23.8 kg)	53.4 lbs (24.2 kg)	55.6 lbs (25.4 kg)	58.9 lbs (26.7 kg)	65.5 lbs (29.7 kg)
1" (DN25)	52.3 lbs (23.7 kg)	54.5 lbs (24.7 kg)	56.7 lbs (25.7 kg)	60.0 lbs (27.2 kg)	66.6 lbs (30.2 kg)
1 1/2" (DN40)	56.9 lbs (25.8 kg)	60.2 lbs (27.3 kg)	63.3 lbs (28.7 kg)	68.8 lbs (31.2 kg)	75.4 lbs (34.2 kg)
2" (DN50)	56.7 lbs (25.7 kg)	64.4 lbs (29.2 kg)	66.8 lbs (30.3 kg)	73.9 lbs (33.5 kg)	80.5 lbs (36.5 kg)



CONTROLS SUPPLY CHAIN

VALVES ACTUATORS INSTRUMENTATIONS