

Masoneilan™ 21000 Series

Top Guided Globe Valves
with **Lo-dB™**, Anti-Cavitation,
Bellows and API 6A High
Pressure Capabilities



Table of contents

Numbering System	3.....
Ratings/Connections	5.....
C_v and F_L versus Travel.....	6-16
Materials of Construction	17-22
Bellows Seal Design Features 21000 BS Series	23
Materials of Construction	24-26
21000 Series API 6A.....	27.....
C_v and F_L versus Travel.....	28.....
Materials of Construction	29-35
API Dimensions.....	36.....
API Weights.....	37.....
Dimensions (inches).....	38-39
Dimensions (mm).....	40-41
Weights.....	42.....
Actuator Dimensions and Weights (in./lbs).....	43
Actuator Dimensions and Weights (mm/kg).....	44

Numbering System

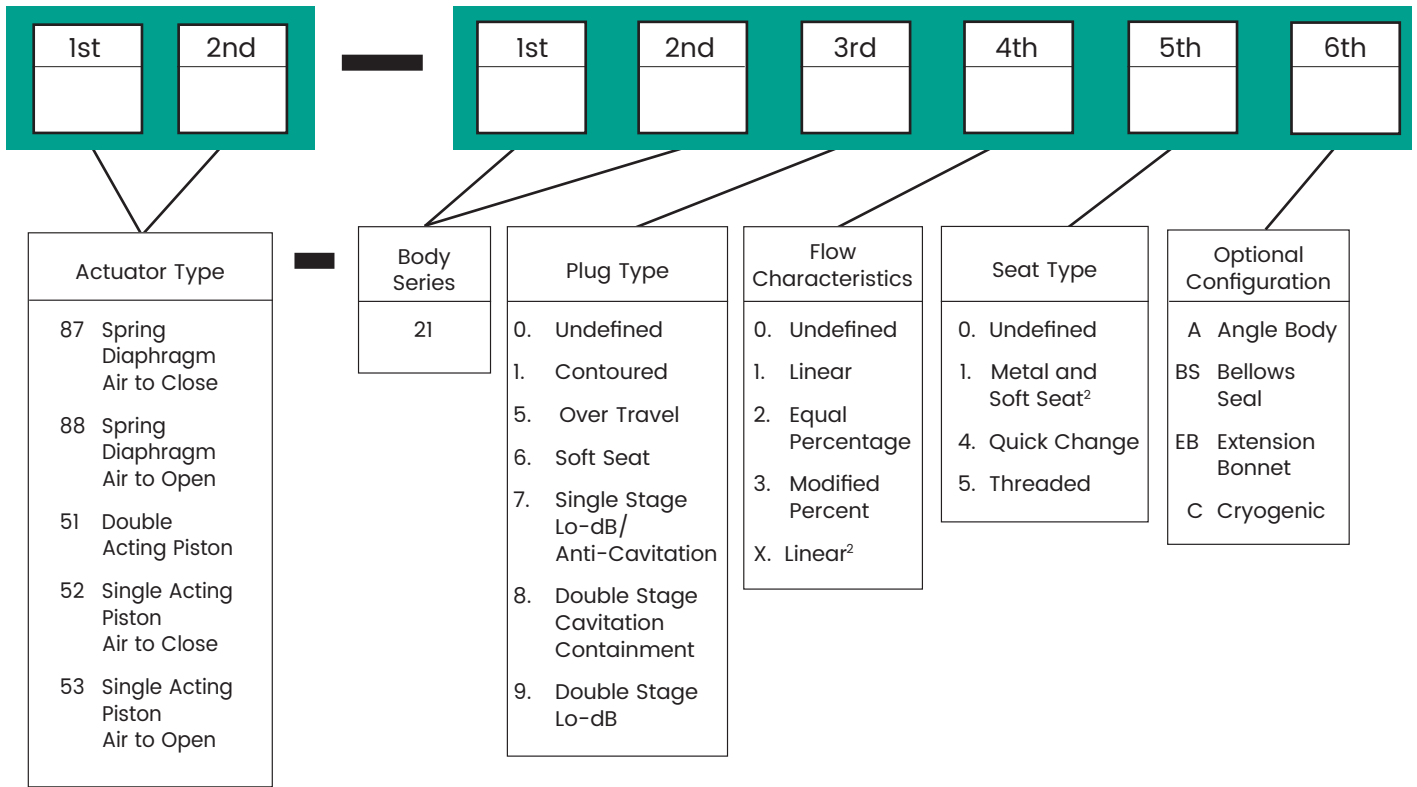

Notes:

1. Configuration for 21000 API 6A. See more details on page 27.
 For high temperature application, consult Engineering.

2. Over Travel Plug only.

Temperature Range/Seat Leakage

Contoured Trim

Valve Size		Body ¹ Rating	Seat Type	Packing Material	Temperature Range ²				Cryogenic Extension		Seat Leakage IEC 60534-4 and ANSI/ FCI 70.2 Class	
Inch	mm				Standard Bonnet		Extension Bonnet		min.	max.		
					min.	max.	min.	max.				
0.75 to 8	20 to 200	ASME Class 150 to 2500 and equivalent PN	Metal	PTFE, LE or LE FireSafe Packing	-20°F (-29°C)	+450°F (+232°C)	-50°F (-46°C)	+800°F (+427°C)			IV	V
				Graphite Packing	-20°F (-29°C)	+800°F (+427°C)	-50°F (-46°C)	+800°F (+427°C)				
				V-ring					-320°F (-196°C)	+212°F (+100°C)		
			Soft Seat ⁴	Any	-20°F (-29°C)	+450°F (+232°C)	-50°F (-46°C)	+450°F (+232°C)			VI	

Lo-dB/Anti-Cavitation Trim (1 or 2 Stage Design)³

Valve Size		Body ¹ Rating	Seat Type	Packing Material	Temperature Range ²				Cryogenic Extension		Seat Leakage IEC 60534-4 and ANSI/ FCI 70.2 Class	
Inch	mm				Standard Bonnet		Extension Bonnet		min.	max.		
					min.	max.	min.	max.				
0.75 to 8	20 to 200	ASME Class 150 to 2500 and equivalent PN	Metal	PTFE, LE or LE FireSafe Packing	-20°F (-29°C)	+450°F (+232°C)	-50°F (-46°C)	+800°F (+427°C)			IV	V
				Graphite Packing	-20°F (-29°C)	+800°F (+427°C)	-50°F (-46°C)	+800°F (+427°C)				
				V-ring					-320°F (-196°C)	+212°F (+100°C)		

- ASME Class 900-1500 available only in 0.75 to 4 inch (20 to 100 mm) sizes.
ASME Class 2500 available only in 0.75 to 2 inch (20 to 50 mm) sizes.
- See Materials of Construction Tables for other temperature limitations.
- 2-Stage design only available with Quick Change seat rings.
- Soft seat is limited to a maximum of 1000 psi (70 bar) shut-off and a maximum of 450°F (232°C).

Masonellan 21000 Series products meet design and materials requirements of PED Directive 2014/68/EU.

Ratings/Connections¹

Valve Size		ASME Class 150 (PN 20)					ASME Class 300 (PN 50)					ASME Class 600 (PN 100)				
Inch	mm	RF	SW	THD	RTJ	BW	RF	SW	THD	RTJ	BW	RF	SW	THD	RTJ	BW
0.75	20	X	X	X			X	X	X	X		X	X	X	X	
1	25	X	X	X			X	X	X	X		X	X	X	X	
1.5	40	X	X	X			X	X	X	X		X	X	X	X	
2	50	X	X	X		X	X	X	X	X	X	X	X	X	X	X
3	80	X				X	X			X	X	X			X	X
4	100	X				X	X			X	X	X			X	X
6	150	X				X	X			X	X	X			X	X
8	200	X				X	X			X	X	X			X	X

Valve Size		ASME Class 900 (PN 150)					ASME Class 1500 (PN 250)					ASME Class 2500 (PN 420)				
Inch	mm	RF	SW	THD	RTJ	BW	RF	SW	THD	RTJ	BW	RF	SW	THD	RTJ	BW
0.75	20	X	X		X		X	X		X		X	X		X	
1	25	X	X		X		X	X		X		X	X		X	
1.5	40	X	X		X		X	X		X		X	X		X	
2	50	X	X		X	X	X	X		X	X	X	X		X	X
3	80	X			X	X	X			X	X					
4	100	X			X	X	X			X	X					

1. Standard flange of Ra 125-250. Other flange facings and surface finishes available.

C_V and F_L Versus Travel

Contoured Trim

Direction: FLOW-TO-OPEN (FTO)
Flow Characteristic: LINEAR

Percent of Travel:							10	20	30	40	50	60	70	80	90	100
F _L :							0.93	0.93	0.92	0.92	0.91	0.91	0.91	0.9	0.9	0.9
Valve Size		ASME Rating	Orifice Diameter		Travel		Rated C _V									
Inch	mm		Inch	mm	Inch	mm										
Close clearance 0.75 and 1 ⁽¹⁾	Close clearance 20 and 25	150-600	0.125	3.2	0.8	20.3	0.01	0.02	0.03	0.04	0.05	0.06	0.07	0.08	0.09	0.1
			0.25	6.4	0.8	20.3	0.02	0.04	0.06	0.07	0.09	0.11	0.13	0.15	0.18	0.2
			0.25	6.4	0.8	20.3	0.03	0.06	0.08	0.11	0.13	0.16	0.19	0.23	0.27	0.3
			0.25	6.4	0.8	20.3	0.04	0.08	0.11	0.14	0.18	0.22	0.26	0.3	0.36	0.4
			0.25	6.4	0.8	20.3	0.06	0.12	0.17	0.22	0.27	0.32	0.38	0.45	0.54	0.6
			0.25	6.4	0.8	20.3	0.08	0.16	0.22	0.29	0.36	0.43	0.51	0.6	0.72	0.8
			0.25	6.4	0.8	20.3	0.1	0.2	0.28	0.36	0.45	0.54	0.64	0.76	0.9	1
0.75	20	150-1500	0.25	6.4	0.8	20.3	0.15	0.31	0.46	0.61	0.77	0.94	1.12	1.31	1.50	1.7
			0.375	9.5	0.8	20.3	0.34	0.68	1.02	1.36	1.72	2.11	2.51	2.93	3.36	3.80
			0.5	12.7	0.8	20.3	0.54	1.07	1.60	2.15	2.72	3.33	3.96	4.62	5.30	6
			0.812	20.6	0.8	20.3	1.09	2.15	3.21	4.30	5.45	6.65	7.92	9.24	10.60	12
1	25	150-1500	0.25	6.4	0.8	20.3	0.15	0.31	0.46	0.61	0.77	0.94	1.12	1.31	1.50	1.7
			0.375	9.5	0.8	20.3	0.34	0.68	1.02	1.36	1.73	2.11	2.51	2.93	3.36	3.8
			0.5	12.7	0.8	20.3	0.54	1.08	1.61	2.15	2.72	3.33	4.0	4.63	5.31	6
1.5	40	150-1500	0.812	20.6	0.8	20.3	1.09	2.16	3.22	4.31	5.45	6.66	7.93	9.25	10.6	12
			0.25	6.4	0.8	20.3	0.15	0.31	0.46	0.61	0.77	0.94	1.12	1.31	1.50	1.7
			0.375	9.5	0.8	20.3	0.34	0.68	1.02	1.36	1.73	2.11	2.51	2.93	3.36	3.8
			0.5	12.7	0.8	20.3	0.54	1.08	1.61	2.15	2.72	3.33	4.0	4.63	5.31	6
			0.812	20.6	0.8	20.3	1.18	2.33	3.48	4.66	5.9	7.2	8.58	10	11.5	13
			0.994	25.2	0.8	20.3	2.11	4.18	6.06	7.91	9.89	11.67	13.65	15.39	16.65	18
2	50	150-1500	1.25	31.8	0.8	20.3	2.27	4.49	6.7	8.97	11.3	13.9	16.5	19.3	22.1	25
			1.625	41.3	0.8	20.3	3.17	6.29	9.38	12.6	15.9	19.4	23.1	27	31	35
			0.25	6.4	0.8	20.3	0.15	0.31	0.46	0.61	0.77	0.94	1.12	1.31	1.50	1.7
			0.375	9.5	0.8	20.3	0.34	0.68	1.02	1.36	1.73	2.11	2.51	2.93	3.36	3.8
			0.5	12.7	0.8	20.3	0.54	1.08	1.61	2.15	2.72	3.33	4.0	4.63	5.31	6
			0.812	20.6	0.8	20.3	1.36	2.7	4.02	5.38	6.81	8.32	9.91	11.6	13.3	15
			0.994	25.2	0.8	20.3	2.22	4.41	6.4	8.35	10.44	12.32	14.4	16.25	17.58	19
3	80	150-1500	1.25	31.8	0.8	20.3	2.36	4.67	6.97	9.33	11.8	14.4	17.2	20.1	23	26
			1.625	41.3	0.8	20.3	4.17	8.27	12.3	16.5	20.9	25.5	30.4	35.5	40.7	46
			0.994	25.2	1.5	38.1	2.34	4.65	6.74	8.79	11.0	12.97	15.16	17.1	18.5	20
			1.25	31.8	1.5	38.1	2.81	5.57	8.31	11.1	14.1	17.2	20.5	23.9	27.4	31
			1.625	41.3	1.5	38.1	4.26	8.45	12.6	16.9	21.3	26.1	31.1	36.2	41.6	47
4	100	150-1500	2.000	50.8	1.5	38.1	8.43	16.7	24.26	31.65	39.57	46.68	54.58	61.57	66.6	72
			2.625	66.7	1.5	38.1	9.97	19.8	29.5	39.5	49.9	61	72.7	84.8	97.3	110
			0.994	25.2	1.5	38.1	2.34	4.65	6.74	8.79	11.0	12.97	15.16	17.1	18.5	20
			1.625	41.3	1.5	38.1	4.44	8.81	13.1	17.6	22.3	27.2	32.4	37.8	43.3	49
			2.000	50.8	1.5	38.1	8.67	17.2	24.93	32.53	40.67	47.97	56.1	63.28	68.45	74
			2.625	66.7	1.5	38.1	10.3	20.3	30.3	40.6	51.3	62.7	74.7	87.1	99.9	113
6	150	150-600	3.5	88.9	1.5	38.1	17.7	35.1	52.3	70	88.6	108	129	150	172	195
			2.000	50.8	2	50.8	9.5	18.8	27.3	35.6	44.5	52.5	61.4	69.3	74.9	81
			2.625	66.7	2	50.8	11.4	22.7	33.8	45.2	57.2	69.9	83.2	97.2	111	126
			3.5	88.9	2	50.8	18.9	37.4	55.7	74.6	94.5	115	137	160	184	208
			4.375	111	2	50.8	35.13	69.7	101	131.9	164.9	194.5	227.4	256.5	277.5	300
8	200	150-600	5	127	2	50.8	36.3	71.9	107	143	182	222	264	308	354	400
			3.5	88.9	2	50.8	20	40	60	80	101	124	148	172	197	224
			4.375	111	2	50.8	37	74	108	141	176	207	243	274	296	320
			5	127	2	50.8	37	75	112	148	187	230	274	319	365	415
			6.25	158.7	2.5	63.5	57	115	173	228	289	355	422	493	563	640

Standard Bellows Seal construction available for ASME Class 150 - 300 (PN 20 - PN 50) and capacities of C_V = 1.7 and higher.

1. Close clearance 0.75 and 1 are available in quick change trim only (Model 21114).

2. Models 21614 and 21615 available only in Cv ranges as indicated by green background.

C_v and F_L Versus Travel

Contoured Trim

Direction: FLOW-TO-OPEN (FTO)
Flow Characteristic: EQUAL PERCENTAGE

Percent of Travel:							10	20	30	40	50	60	70	80	90	100	
F _L :							0.93	0.93	0.93	0.93	0.93	0.92	0.92	0.91	0.91	0.91	0.90
Valve Size		ASME Rating	Orifice Diameter		Travel		Rated C _v										
Inch	mm		Inch	mm	Inch	mm											
0.75 ⁽¹⁾	20	150-1500	0.25	6.4	0.8	20.3	0.05	0.08	0.11	0.18	0.3	0.5	0.8	1.1	1.5	1.7	
			0.375	9.5	0.8	20.3	0.12	0.17	0.24	0.39	0.68	1.13	1.76	2.5	3.26	3.8	
			0.5	12.7	0.8	20.3	0.18	0.27	0.38	0.62	1.07	1.79	2.77	3.95	5.14	6	
			0.812	20.6	0.8	20.3	0.43	0.6	0.86	1.22	2.32	4.3	6.8	9.13	10.7	12	
1 ⁽¹⁾	25	150-1500	0.25	6.4	0.8	20.3	0.05	0.08	0.11	0.18	0.3	0.5	0.8	1.1	1.5	1.7	
			0.375	9.5	0.8	20.3	0.12	0.17	0.24	0.39	0.68	1.13	1.76	2.5	3.26	3.8	
			0.5	12.7	0.8	20.3	0.18	0.27	0.38	0.62	1.07	1.79	2.77	3.95	5.14	6	
			0.812	20.6	0.8	20.3	0.4	0.6	0.86	1.22	2.32	4.3	6.8	9.13	10.7	12	
1.5	40	150-1500	0.25	6.4	0.8	20.3	0.05	0.08	0.11	0.18	0.3	0.5	0.8	1.1	1.5	1.7	
			0.375	9.5	0.8	20.3	0.12	0.17	0.24	0.39	0.68	1.13	1.76	2.5	3.26	3.8	
			0.5	12.7	0.8	20.3	0.18	0.27	0.38	0.62	1.07	1.79	2.77	3.95	5.14	6	
			0.812	20.6	0.8	20.3	0.4	0.59	0.82	1.34	2.32	3.87	6.01	8.57	11.1	13	
			0.994	25.2	0.8	20.3	0.43	0.73	1.14	1.73	2.69	4.61	6.93	10.76	14.84	18	
			1.25	31.8	0.8	20.3	0.77	1.13	1.58	2.58	4.46	7.45	11.6	16.5	21.4	25	
2	50	150-1500	0.25	6.4	0.8	20.3	0.05	0.08	0.11	0.18	0.3	0.5	0.8	1.1	1.5	1.7	
			0.375	9.5	0.8	20.3	0.12	0.17	0.24	0.39	0.68	1.13	1.76	2.5	3.26	3.8	
			0.5	12.7	0.8	20.3	0.18	0.27	0.38	0.62	1.07	1.79	2.77	3.95	5.14	6	
			0.812	20.6	0.8	20.3	0.46	0.68	0.95	1.55	2.68	4.47	6.93	9.88	12.9	15	
			0.994	25.2	0.8	20.3	0.46	0.77	1.2	1.82	2.84	4.87	7.32	11.36	15.67	19	
			1.25	31.8	0.8	20.3	0.8	1.17	1.64	2.68	4.64	7.75	12	17.1	22.3	26	
3	80	150-1500	1.625	41.3	0.8	20.3	1.3	1.7	2.51	3.56	6.76	12.5	19.8	26.6	31.3	35	
			0.994	25.2	1.5	38.1	0.48	0.81	1.26	1.92	2.99	5.13	7.7	11.96	16.49	20	
			1.25	31.8	1.5	38.1	0.95	1.4	1.96	3.2	5.53	9.24	14.3	20.4	26.6	31	
			1.625	41.3	1.5	38.1	1.45	2.12	2.97	4.85	8.39	14	21.7	31	40.3	47	
			2.000	50.8	1.5	38.1	1.73	2.93	4.55	6.91	10.76	18.45	27.72	43	59.36	72	
			2.625	66.7	1.5	38.1	4	5.5	7.88	11.2	21.2	39.4	62.3	83.7	98.5	110	
4	100	150-1500	0.994	25.2	1.5	38.1	0.74	1.14	1.76	2.07	2.99	5.13	7.7	11.96	16.49	20	
			1.625	41.3	1.5	38.1	1.51	2.21	3.09	5.06	8.74	14.6	22.7	32.3	42	49	
			2.000	50.8	1.5	38.1	2.73	4.22	6.51	7.66	11.1	18.97	28.49	44.24	61	74	
			2.625	66.7	1.5	38.1	3.47	5.09	7.14	11.7	20.2	33.7	52.2	74.5	96.8	113	
			3.5	88.9	1.5	38.1	7	9.7	14	19.9	37.6	69.8	110	148	175	195	
6	150	150-600	2	50.8	2	50.8	2.99	4.62	7.13	8.38	12.1	20.76	31.19	48.42	66.78	81	
			2.625	66.7	2	50.8	3.87	5.68	7.96	13	22.5	37.5	58.3	83	108	126	
			3.5	88.9	2	50.8	6.4	9.37	13.1	21.5	37.1	62	96.2	137	178	208	
			4.375	111	2	50.8	11	17.1	26.4	31	44.85	76.89	115.5	179.34	247.35	300	
			5	127	2	50.8	14.4	20	28.7	40.7	77.2	143	227	304	358	400	
8	200	150-600	3.5	88.9	2	50.8	7	10	15	24	40	72	112	154	197	224	
			4.375	111	2	50.8	8	13	20	31	48	82	123	191	264	320	
			5	127	2	50.8	13	19	28	44	74	133	207	285	365	415	
			6.25	158.7	2.5	63.5	20	30	43	68	115	205	320	440	562	640	

1. Close clearance 0.75 and 1 are available in quick change trim only (Model 21114).

2. Models 21614 and 21615 available only in Cv ranges as indicated by green background.

C_v and F_L Versus Travel

Contoured Plug

Direction: FLOW-TO-OPEN (FTO)
Flow Characteristic: MODIFIED PERCENT

Percent of Travel:							10	20	30	40	50	60	70	80	90	100	
F _L :							0.93	0.93	0.93	0.93	0.93	0.92	0.92	0.91	0.91	0.91	0.9
Valve Size		ASME Rating	Orifice Diameter		Travel		Rated C _v										
Inch	mm		Inch	mm	Inch	mm											
0.75	20	150-1500	0.25	6.4	0.8	20.3	0.04	0.07	0.14	0.28	0.5	0.73	0.99	1.28	1.52	1.7	
			0.375	9.5	0.8	20.3	0.09	0.15	0.31	0.64	1.13	1.64	2.22	2.86	3.4	3.8	
			0.5	12.7	0.8	20.3	0.14	0.24	0.49	1	1.78	2.59	3.5	4.5	5.38	6	
			0.812	20.6	0.8	20.3	0.32	0.74	1.27	3.25	5.47	7.78	9.6	10.85	11.57	12	
1	25	150-1500	0.25	6.4	0.8	20.3	0.04	0.07	0.14	0.28	0.5	0.73	0.99	1.28	1.52	1.7	
			0.375	9.5	0.8	20.3	0.09	0.15	0.31	0.64	1.13	1.64	2.22	2.86	3.4	3.8	
			0.5	12.7	0.8	20.3	0.14	0.24	0.49	1	1.78	2.59	3.5	4.5	5.38	6	
			0.812	20.6	0.8	20.3	0.32	0.74	1.27	3.25	5.47	7.78	9.6	10.85	11.57	12	
1.5	40	150-1500	0.25	6.4	0.8	20.3	0.04	0.07	0.14	0.28	0.5	0.73	0.99	1.28	1.52	1.7	
			0.375	9.5	0.8	20.3	0.09	0.15	0.31	0.64	1.13	1.64	2.22	2.86	3.4	3.8	
			0.5	12.7	0.8	20.3	0.14	0.24	0.49	1	1.78	2.59	3.5	4.5	5.38	6	
			0.812	20.6	0.8	20.3	0.29	0.52	1.07	2.18	3.86	5.62	7.6	9.77	11.65	13	
			0.994	25.2	0.8	20.3	0.41	0.71	1.48	3.01	5.34	7.78	10.53	13.53	16.13	18	
			1.25	31.8	0.8	20.3	0.68	1.55	2.66	6.77	11.4	16.2	20	22.6	24.11	25	
			1.625	41.3	0.8	20.3	0.95	2.17	3.72	9.48	15.97	22.69	28	31.65	33.76	35	
2	50	150-1500	0.25	6.4	0.8	20.3	0.04	0.07	0.14	0.28	0.5	0.73	0.99	1.28	1.52	1.7	
			0.375	9.5	0.8	20.3	0.09	0.15	0.31	0.64	1.13	1.64	2.22	2.86	3.4	3.8	
			0.5	12.7	0.8	20.3	0.14	0.24	0.49	1	1.78	2.59	3.5	4.5	5.38	6	
			0.812	20.6	0.8	20.3	0.34	0.59	1.23	2.51	4.45	6.48	8.77	11.28	13.44	15	
			0.994	25.2	0.8	20.3	0.43	0.75	1.56	3.18	5.64	8.21	11.11	14.28	17	19	
			1.25	31.8	0.8	20.3	0.59	1.03	2.14	4.35	7.71	11.23	15.2	19.54	23.3	26	
			1.625	41.3	0.8	20.3	1.24	2.85	4.89	12.46	20.99	29.82	36.81	41.59	44.37	46	
3	80	150-1500	0.994	25.2	1.5	38.1	0.45	0.79	1.64	3.35	5.93	8.64	11.7	15	17.92	20	
			1.25	31.8	1.5	38.1	0.7	1.23	2.55	5.19	9.19	13.4	18.13	23.3	27.78	31	
			1.625	41.3	1.5	38.1	1.06	1.86	3.86	7.87	13.94	20.3	27.49	35.33	42.12	47	
			2.000	50.8	1.5	38.1	1.63	2.85	5.92	12.05	21.36	31.11	42.11	54.12	64.53	72	
			2.625	66.7	1.5	38.1	2.97	6.82	11.68	29.79	50.18	71.3	88	99.46	106.1	110	
4	100	150-1500	0.994	25.2	1.5	38.1	0.45	0.79	1.64	3.35	5.93	8.64	11.7	15	17.92	20	
			1.625	41.3	1.5	38.1	1.11	1.94	4.03	8.2	14.53	21.17	28.66	36.83	43.91	49	
			2.000	50.8	1.5	38.1	1.67	2.93	6.08	12.39	21.95	31.98	43.28	55.63	66.32	74	
			2.625	66.7	1.5	38.1	2.56	4.48	9.29	18.92	33.52	48.83	66.09	84.94	101.27	113	
			3.5	88.9	1.5	38.1	5.27	12.1	20.7	52.8	88.96	126.4	156.04	176.32	188.08	195	
6	150	150-600	2.000	50.8	2	50.8	1.83	3.21	6.66	13.56	24.02	35	47.38	60.89	72.6	81	
			2.625	66.7	2	50.8	2.85	4.99	10.36	21.1	37.37	54.44	73.7	94.7	112.92	126	
			3.5	88.9	2	50.8	4.71	8.25	17.1	34.82	61.69	89.88	121.66	156.35	186.41	208	
			4.375	111	2	50.8	6.79	11.89	24.66	50.22	88.98	129.63	175.47	225.51	268.86	300	
			5	127	2	50.8	10.8	24.8	42.48	108.32	182.48	259.28	320.08	361.68	385.8	400	

C_v and F_L Versus Travel

Direction: FLOW-TO-CLOSE (FTC)
Flow Characteristic: LINEAR TRIM

Contoured Plug

Percent of Travel:							10	20	30	40	50	60	70	80	90	100
F _L :							0.53	0.56	0.60	0.68	0.75	0.78	0.81	0.84	0.85	0.86
Valve Size		ASME Rating	Orifice Diameter		Travel		Rated C _v									
Inch	mm		Inch	mm	Inch	mm										
0.75 ⁽¹⁾	20	150-1500	0.25	6.4	0.8	20.3	0.225	0.39	0.46	0.61	0.77	0.94	1.12	1.31	1.5	1.7
			0.375	9.5	0.8	20.3	0.51	0.85	1.02	1.36	1.72	2.11	2.51	2.93	3.36	3.8
			0.5	12.7	0.8	20.3	0.81	1.34	1.6	2.15	2.72	3.33	3.96	4.62	5.3	6
			0.812	20.6	0.8	20.3	1.635	2.69	3.21	4.3	5.45	6.65	7.92	9.24	10.6	12
1 ⁽¹⁾	25	150-1500	0.25	6.4	0.8	20.3	0.225	0.39	0.46	0.61	0.77	0.94	1.12	1.31	1.5	1.7
			0.375	9.5	0.8	20.3	0.51	0.85	1.02	1.36	1.73	2.11	2.51	2.93	3.36	3.8
			0.5	12.7	0.8	20.3	0.81	1.35	1.61	2.15	2.72	3.33	4	4.63	5.31	6
			0.812	20.6	0.8	20.3	1.635	2.70	3.22	4.31	5.45	6.66	7.93	9.25	10.6	12
1.5	40	150-1500	0.25	6.4	0.8	20.3	0.225	0.39	0.46	0.61	0.77	0.94	1.12	1.31	1.5	1.7
			0.375	9.5	0.8	20.3	0.51	0.85	1.02	1.36	1.73	2.11	2.51	2.93	3.36	3.8
			0.5	12.7	0.8	20.3	0.81	1.35	1.61	2.15	2.72	3.33	4	4.63	5.31	6
			0.812	20.6	0.8	20.3	1.77	2.91	3.48	4.66	5.9	7.2	8.58	10	11.5	13
			0.994	25.2	0.8	20.3	3.15	5.22	6.1	7.91	9.89	11.67	13.65	15.39	16.65	18
			1.25	31.8	0.8	20.3	3.40	5.61	6.7	8.97	11.3	13.9	16.5	19.3	22.1	25
2	50	150-1500	0.25	6.4	0.8	20.3	0.225	0.39	0.46	0.61	0.77	0.94	1.12	1.31	1.5	1.7
			0.375	9.5	0.8	20.3	0.51	0.85	1.02	1.36	1.73	2.11	2.51	2.93	3.36	3.8
			0.5	12.7	0.8	20.3	0.81	1.35	1.61	2.15	2.72	3.33	4	4.63	5.31	6
			0.812	20.6	0.8	20.3	2.04	3.38	4.02	5.38	6.81	8.32	9.91	11.6	13.3	15
			0.994	25.2	0.8	20.3	3.33	5.51	6.4	8.35	10.44	12.3	14.4	16.25	17.58	19
			1.25	31.8	0.8	20.3	3.54	5.84	6.97	9.33	11.8	14.4	17.2	20.1	23	26
3	80	150-1500	1.625	41.3	0.8	20.3	4.76	7.86	9.38	12.6	15.9	19.4	23.1	27	31	35
			0.994	25.2	1.5	38.1	3.5	5.8	6.74	8.79	11	12.97	15.2	17.1	18.5	20
			1.25	31.8	1.5	38.1	4.22	6.96	8.31	11.1	14.1	17.2	20.5	23.9	27.4	31
			1.625	41.3	1.5	38.1	6.39	10.56	12.6	16.9	21.3	26.1	31.1	36.2	41.6	47
			2.000	50.8	1.5	38.1	12.6	20.9	24.26	31.65	39.57	46.68	54.58	61.57	66.6	72
4	100	150-1500	2.625	66.7	1.5	38.1	14.96	24.75	29.5	39.5	49.9	61	72.7	84.8	97.3	110
			0.994	25.2	1.5	38.1	3.5	5.8	6.74	8.79	11	12.97	15.2	17.1	18.5	20
			1.625	41.3	1.5	38.1	6.66	11.01	13.1	17.6	22.3	27.2	32.4	37.8	43.3	49
			2.000	50.8	1.5	38.1	12.95	21.46	24.93	32.53	40.67	47.97	56.1	63.28	68.45	74
			2.625	66.7	1.5	38.1	15.45	25.38	30.3	40.6	51.3	62.7	74.7	87.1	99.9	113
6	150	150-600	3.5	88.9	1.5	38.1	26.55	43.88	52.3	70	88.6	108	129	150	172	195
			2.000	50.8	2	50.	14.18	23.49	27.29	35.6	44.5	52.5	61.4	69.2	74.9	81
			2.625	66.7	2	50.	17.1	28.38	33.8	45.2	57.2	69.9	83.2	97.2	111	126
			3.5	88.9	2	50.	28.35	46.75	55.7	74.6	94.5	115	137	160	184	208
			4.375	111	2	50.	52.5	87	101	131.9	164.9	194.5	227.4	256.5	277.5	300
8	200	150-600	5	127	2	50.	54.45	89.88	107	143	182	222	264	308	354	400
			3.5	88.9	2	50.	30	50	60	80	101	124	148	172	197	224
			4.375	111	2	50.	54.5	92.8	108	141	176	207	243	274	296	320
			5	127	2	50.	55.5	93.75	112	148	187	230	274	319	365	415
			6.25	158.7	2.5	63.	85.5	143.7	173	228	289	355	422	493	563	640

1. Close clearance 0.75 and 1 are available in quick change trim only (Model 21114).
2. Models 21614 and 21615 available only in Cv ranges as indicated by green background.

C_v and F_L Versus Travel

Contoured Plug

Direction: FLOW-TO-CLOSE (FTC)
Flow Characteristic: EQUAL PERCENT

Percent of Travel:							10	20	30	40	50	60	70	80	90	100	
F _L :							0.53	0.53	0.55	0.63	0.72	0.80	0.80	0.80	0.80	0.80	0.80
Valve Size		ASME Rating	Orifice Diameter		Travel		Rated C _v										
Inch	mm		Inch	mm	Inch	mm											
0.75 ⁽¹⁾	20	150-1500	0.25	6.4	0.8	20.3	0.1	0.1	0.2	0.22	0.3	0.5	0.8	1.1	1.5	1.7	
			0.375	9.5	0.8	20.3	0.2	0.2	0.3	0.39	0.68	1.13	1.76	2.5	3.26	3.8	
			0.5	12.7	0.8	20.3	0.3	0.4	0.5	0.64	1.07	1.79	2.77	3.95	5.14	6	
			0.812	20.6	0.8	20.3	0.6	0.8	1.2	1.48	2.32	4.3	6.8	9.13	10.7	12	
1 ⁽¹⁾	25	150-1500	0.25	6.4	0.8	20.3	0.1	0.1	0.2	0.22	0.3	0.5	0.8	1.1	1.5	1.7	
			0.375	9.5	0.8	20.3	0.2	0.2	0.3	0.39	0.68	1.13	1.76	2.5	3.26	3.8	
			0.5	12.7	0.8	20.3	0.3	0.4	0.5	0.64	1.07	1.79	2.77	3.95	5.14	6	
			0.812	20.6	0.8	20.3	0.6	0.8	1.2	1.48	2.32	4.3	6.8	9.13	10.7	12	
1.5	40	150-1500	0.25	6.4	0.8	20.3	0.1	0.1	0.2	0.22	0.3	0.5	0.8	1.1	1.5	1.7	
			0.375	9.5	0.8	20.3	0.2	0.2	0.3	0.39	0.68	1.13	1.76	2.5	3.26	3.8	
			0.5	12.7	0.8	20.3	0.3	0.4	0.5	0.64	1.07	1.79	2.77	3.95	5.14	6	
			0.812	20.6	0.8	20.3	0.6	0.8	1.1	1.48	2.32	3.87	6.01	8.57	11.1	13	
			0.994	25.2	0.8	20.3	0.66	1.03	1.58	1.86	2.69	4.61	6.93	10.76	14.84	18	
			1.25	31.8	0.8	20.3	1.2	1.6	2.2	2.76	4.46	7.45	11.6	16.5	21.4	25	
2	50	150-1500	0.25	6.4	0.8	20.3	0.1	0.1	0.2	0.22	0.3	0.5	0.8	1.1	1.5	1.7	
			0.375	9.5	0.8	20.3	0.2	0.2	0.3	0.39	0.68	1.13	1.76	2.5	3.26	3.8	
			0.5	12.7	0.8	20.3	0.3	0.4	0.5	0.64	1.07	1.79	2.77	3.95	5.14	6	
			0.812	20.6	0.8	20.3	0.7	1.0	1.3	1.64	2.68	4.47	6.93	9.88	12.9	15	
			0.994	25.2	0.8	20.3	0.7	1.08	1.67	1.97	2.84	4.87	7.32	11.36	15.67	19	
			1.25	31.8	0.8	20.3	1.2	1.6	2.3	2.76	4.64	7.75	12	17.1	22.3	26	
3	80	150-1500	0.994	25.2	1.5	38.1	0.74	1.14	1.76	2.07	2.99	5.13	7.7	11.96	16.49	20	
			1.25	31.8	1.5	38.1	1.4	2.0	2.7	3.4	5.53	9.24	14.3	20.4	26.6	31	
			1.625	41.3	1.5	38.1	2.2	3.0	4.2	5.24	8.39	14	21.7	31	40.3	47	
			2.000	50.8	1.5	38.1	2.66	4.1	6.34	7.45	10.76	18.45	27.72	43	59.36	72	
			2.625	66.7	1.5	38.1	6.0	7.7	11.0	13.5	21.2	39.4	62.3	83.7	98.5	110	
4	100	150-1500	0.994	25.2	1.5	38.1	0.74	1.14	1.76	2.07	2.99	5.13	7.7	11.96	16.49	20	
			1.625	41.3	1.5	38.1	2.3	3.1	4.3	5.41	8.74	14.6	22.7	32.3	42	49	
			2.000	50.8	1.5	38.1	2.73	4.22	6.51	7.66	11.1	18.97	28.49	44.24	61	74	
			2.625	66.7	1.5	38.1	5.2	7.1	10.0	12.55	20.2	33.7	52.2	74.5	96.8	113	
			3.5	88.9	1.5	38.1	10.5	13.6	19.6	24.1	37.6	69.8	110	148	175	195	
6	150	150-600	2.000	50.8	2	50.8	3	4.62	7.13	8.38	12.1	20.76	31.19	48.42	66.78	81	
			2.625	66.7	2	50.8	5.8	8.0	11.1	13.9	22.5	37.5	58.3	83	108	126	
			3.5	88.9	2	50.8	9.6	13.1	18.3	23	37.1	62	96.2	137	178	208	
			4.375	111	2	50.8	11.1	17.1	26.4	31	44.85	76.89	115.5	179.34	247.35	300	
			5	127	2	50.8	21.6	28.0	40.2	49.4	77.2	143	227	304	358	400	
8	200	150-600	3.5	88.9	2	50.8	10.5	14.0	21.0	25.75	40	72	112	154	197	224	
			4.375	111	2	50.8	11.8	18.2	28.2	33.1	48	82	123	191	264	320	
			5	127	2	50.8	19.5	26.6	39.2	47.9	74	133	207	285	365	415	
			6.25	158.7	2.5	63.5	30.0	42.0	60.2	73.9	115	205	320	440	562	640	

1. Close clearance 0.75 and 1 are available in quick change trim only (Model 21114).

2. Models 21614 and 21615 available only in C_v ranges as indicated by green background.

C_v and F_L Versus Travel

Contoured Plug

Direction: FLOW-TO-CLOSE (FTC)
Flow Characteristic: MODIFIED PERCENT

Percent of Travel:							10	20	30	40	50	60	70	80	90	100	
F _L :							0.53	0.53	0.55	0.63	0.72	0.80	0.80	0.80	0.80	0.80	0.80
Valve Size		ASME Rating	Orifice Diameter		Travel		Rated C _v										
Inch	mm		Inch	mm	Inch	mm											
0.75	20	150-1500	0.25	6.4	0.8	20.3	0.06	0.09	0.19	0.3	0.5	0.73	0.99	1.28	1.52	1.7	
			0.375	9.5	0.8	20.3	0.13	0.21	0.43	0.68	1.13	1.64	2.22	2.86	3.4	3.8	
			0.5	12.7	0.8	20.3	0.2	0.33	0.68	1.08	1.78	2.59	3.51	4.51	5.38	6	
			0.812	20.6	0.8	20.3	0.48	1.03	1.79	3.91	5.47	7.78	9.6	10.85	11.57	12	
1	25	150-1500	0.25	6.4	0.8	20.3	0.06	0.09	0.19	0.3	0.5	0.73	0.99	1.28	1.52	1.7	
			0.375	9.5	0.8	20.3	0.13	0.21	0.43	0.68	1.13	1.64	2.22	2.86	3.4	3.8	
			0.5	12.7	0.8	20.3	0.2	0.33	0.68	1.08	1.78	2.59	3.51	4.51	5.38	6	
			0.812	20.6	0.8	20.3	0.48	1.03	1.79	3.91	5.47	7.78	9.6	10.85	11.57	12	
1.5	40	150-1500	0.25	6.4	0.8	20.3	0.06	0.09	0.19	0.3	0.5	0.73	0.99	1.28	1.52	1.7	
			0.375	9.5	0.8	20.3	0.13	0.21	0.43	0.68	1.13	1.64	2.22	2.86	3.4	3.8	
			0.5	12.7	0.8	20.3	0.2	0.33	0.68	1.08	1.78	2.59	3.51	4.51	5.38	6	
			0.812	20.6	0.8	20.3	0.44	0.72	1.48	2.34	3.86	5.62	7.6	9.77	11.65	13	
			0.994	25.2	0.8	20.3	0.61	0.99	2.05	3.24	5.34	7.78	10.53	13.53	16.13	18	
			1.25	31.8	0.8	20.3	1	2.15	3.73	8.15	11.4	16.2	20	22.6	24.11	25	
2	50	150-1500	0.25	6.4	0.8	20.3	0.06	0.09	0.19	0.3	0.5	0.73	0.99	1.28	1.52	1.7	
			0.375	9.5	0.8	20.3	0.13	0.21	0.43	0.68	1.13	1.64	2.22	2.86	3.4	3.8	
			0.5	12.7	0.8	20.3	0.2	0.33	0.68	1.08	1.78	2.59	3.51	4.51	5.38	6	
			0.812	20.6	0.8	20.3	0.51	0.83	1.71	2.7	4.45	6.48	8.77	11.28	13.44	15	
			0.994	25.2	0.8	20.3	0.65	1.05	2.17	3.42	5.64	8.21	11.11	14.28	17	19	
			1.25	31.8	0.8	20.3	0.88	1.43	2.96	4.68	7.71	11.23	15.2	19.54	23.3	26	
3	80	150-1500	0.25	6.4	0.8	20.3	0.06	0.09	0.19	0.3	0.5	0.73	0.99	1.28	1.52	1.7	
			0.375	9.5	0.8	20.3	0.13	0.21	0.43	0.68	1.13	1.64	2.22	2.86	3.4	3.8	
			0.5	12.7	0.8	20.3	0.2	0.33	0.68	1.08	1.78	2.59	3.51	4.51	5.38	6	
			0.812	20.6	0.8	20.3	0.44	0.72	1.48	2.34	3.86	5.62	7.6	9.77	11.65	13	
			0.994	25.2	1.5	38.1	0.68	1.1	2.28	3.6	5.93	8.64	11.7	15	17.92	20	
			1.25	31.8	1.5	38.1	1.05	1.7	3.53	5.58	9.19	13.4	18.13	23.3	27.78	31	
4	100	150-1500	0.25	6.4	0.8	20.3	0.06	0.09	0.19	0.3	0.5	0.73	0.99	1.28	1.52	1.7	
			0.375	9.5	0.8	20.3	0.13	0.21	0.43	0.68	1.13	1.64	2.22	2.86	3.4	3.8	
			0.5	12.7	0.8	20.3	0.2	0.33	0.68	1.08	1.78	2.59	3.51	4.51	5.38	6	
			0.812	20.6	0.8	20.3	0.51	0.83	1.71	2.7	4.45	6.48	8.77	11.28	13.44	15	
			0.994	25.2	1.5	38.1	0.68	1.1	2.28	3.6	5.93	8.64	11.7	15	17.92	20	
			1.25	31.8	1.5	38.1	1.05	1.7	3.53	5.58	9.19	13.4	18.13	23.3	27.78	31	
6	150	150-600	0.25	6.4	0.8	20.3	0.06	0.09	0.19	0.3	0.5	0.73	0.99	1.28	1.52	1.7	
			0.375	9.5	0.8	20.3	0.13	0.21	0.43	0.68	1.13	1.64	2.22	2.86	3.4	3.8	
			0.5	12.7	0.8	20.3	0.2	0.33	0.68	1.08	1.78	2.59	3.51	4.51	5.38	6	
			0.812	20.6	0.8	20.3	0.44	0.72	1.48	2.34	3.86	5.62	7.6	9.77	11.65	13	
			0.994	25.2	1.5	38.1	0.68	1.1	2.28	3.6	5.93	8.64	11.7	15	17.92	20	
			1.25	31.8	1.5	38.1	1.05	1.7	3.53	5.58	9.19	13.4	18.13	23.3	27.78	31	
6	150	150-600	2.000	50.8	2	50.8	2.75	4.46	9.23	14.58	24.02	35	47.38	60.89	72.59	81	
			2.625	66.7	2	50.8	4.28	6.93	14.36	22.68	37.37	54.44	73.7	94.71	113	126	
			3.5	88.9	2	50.8	7.07	11.44	23.71	37.44	61.69	89.88	121.66	156.35	186	208	
			4.375	111	2	50.8	10.2	16.5	34.2	54	88.98	129.63	175.47	225.51	269	300	
			5	127	2	50.8	16	34.4	59.6	130.4	182.48	259.28	320.1	361.68	386	400	

C_v and F_L Versus Travel

Direction: FLOW-TO-OPEN (FTO)
Flow Characteristic: LINEAR
Rating: ASME 2500 (PN 420)

Contoured Plug

Percent of Travel:							10	20	30	40	50	60	70	80	90	100	
F _L :							0.93	0.93	0.92	0.92	0.91	0.91	0.91	0.9	0.9	0.9	0.90
Valve Size		ASME Rating	Orifice Diameter		Travel		Rated C _v										
Inch	mm		Inch	mm	Inch	mm											
0.75 ⁽¹⁾	20	2500	0.25	6.4	0.8	20.3	0.15	0.31	0.46	0.61	0.77	0.94	1.12	1.31	1.5	1.7	
			0.375	9.5	0.8	20.3	0.34	0.68	1.02	1.36	1.7	2.11	2.5	2.9	3.4	3.8	
			0.5	12.7	0.8	20.3	0.54	1.07	1.60	2.2	2.7	3.33	4	4.6	5.30	6	
			0.812	20.6	0.8	20.3	0.70	1.40	2.20	2.80	3.60	4.40	5.30	6.20	7.00	8	
1 ⁽¹⁾	25	2500	0.25	6.4	0.8	20.3	0.15	0.31	0.46	0.61	0.77	0.94	1.12	1.31	1.50	1.7	
			0.375	9.5	0.8	20.3	0.34	0.68	1.02	1.36	1.73	2.11	2.5	2.9	3.4	3.8	
			0.5	12.7	0.8	20.3	0.54	1.08	1.61	2.2	2.7	3.33	4.0	4.6	5.3	6	
			0.812	20.6	0.8	20.3	0.9	1.8	2.7	3.6	4.5	5.6	6.6	7.7	9	10	
1.5	40	2500	0.25	6.4	0.8	20.3	0.15	0.31	0.46	0.61	0.77	0.94	1.12	1.31	1.50	1.7	
			0.375	9.5	0.8	20.3	0.34	0.68	1.02	1.36	1.7	2.11	2.5	2.93	3.4	3.8	
			0.5	12.7	0.8	20.3	0.54	1.08	1.61	2.15	2.7	3.33	4.0	4.6	5.3	6	
			0.812	20.6	0.8	20.3	1.18	2.3	3.5	4.7	5.9	7.2	8.6	10	11.5	13	
			0.994	25.2	0.8	20.3	2.1	4.2	6.1	7.9	9.9	11.7	13.7	15.4	16.7	18	
			1.25	31.8	0.8	20.3	2.3	4.5	6.7	9.0	11.3	13.9	16.5	19.3	22.1	25	
2	50	2500	0.25	6.4	0.8	20.3	0.15	0.31	0.46	0.61	0.77	0.94	1.12	1.31	1.50	1.7	
			0.375	9.5	0.8	20.3	0.34	0.68	1.02	1.36	1.7	2.11	2.5	2.9	3.4	3.8	
			0.5	12.7	0.8	20.3	0.54	1.08	1.61	2.2	2.7	3.33	4.0	4.6	5.3	6	
			0.812	20.6	0.8	20.3	1.4	2.7	4.0	5.4	6.8	8.3	9.9	11.6	13.3	15	
			0.994	25.2	0.8	20.3	2.2	4.4	6.4	8.4	10.4	12.3	14.4	16.3	17.6	19	
			1.25	31.8	0.8	20.3	2.4	4.7	7.0	9.3	11.8	14.4	17.2	20.1	23	26	
			1.625	41.3	0.8	20.3	3.2	6.3	9	12	16	19	23	27	31	35	

1. Close clearance 0.75 and 1 are available in quick change trim only (Model 21114).

2. Models 21614 and 21615 available only in C_v ranges as indicated by green background.

C_v and F_L Versus Travel

Direction: FLOW-TO-OPEN (FTO)
Flow Characteristic: EQUAL PERCENT
Rating: ASME 2500 (PN420)

Contoured Plug

							Percent of Travel:										
							10	20	30	40	50	60	70	80	90	100	
							F _L	0.93	0.93	0.93	0.93	0.93	0.92	0.92	0.91	0.91	0.90
Valve Size		ASME Rating	Orifice Diameter		Travel		Rated C _v										
Inch	mm		Inch	mm	Inch	mm											
0.75 ⁽¹⁾	20	2500	0.25	6.4	0.8	20.3	0.05	0.08	0.11	0.18	0.3	0.5	0.8	1.1	1.5	1.7	
			0.375	9.5	0.8	20.3	0.12	0.17	0.24	0.39	0.68	1.13	1.76	2.5	3.26	3.8	
			0.5	12.7	0.8	20.3	0.18	0.27	0.38	0.62	1.07	1.79	2.77	3.95	5.14	6	
			0.812	20.6	0.8	20.3	0.29	0.41	0.56	0.9	1.5	2.9	4.5	6	7	8	
1 ⁽¹⁾	25	2500	0.25	6.4	0.8	20.3	0.05	0.08	0.11	0.18	0.3	0.5	0.8	1.1	1.5	1.7	
			0.375	9.5	0.8	20.3	0.12	0.17	0.24	0.39	0.68	1.13	1.76	2.5	3.26	3.8	
			0.5	12.7	0.8	20.3	0.18	0.27	0.38	0.62	1.07	1.79	2.77	3.95	5.14	6	
			0.812	20.6	0.8	20.3	0.36	0.51	0.7	1.1	1.9	3.6	5.6	7.4	9	10	
1.5	40	2500	0.25	6.4	0.8	20.3	0.05	0.08	0.11	0.18	0.3	0.5	0.8	1.1	1.5	1.7	
			0.375	9.5	0.8	20.3	0.12	0.17	0.24	0.39	0.68	1.13	1.76	2.5	3.26	3.8	
			0.5	12.7	0.8	20.3	0.18	0.27	0.38	0.62	1.07	1.79	2.77	3.95	5.14	6	
			0.812	20.6	0.8	20.3	0.4	0.59	0.82	1.34	2.32	3.87	6.01	8.57	11.1	13	
			0.994	25.2	0.8	20.3	0.43	0.73	1.14	1.73	2.69	4.61	6.93	10.76	14.84	18	
			1.25	31.8	0.8	20.3	0.72	1.02	1.4	2.2	3.8	7.2	11	15	18	20	
			1.625	41.3	0.8	20.3	0.9	1.28	1.76	2.8	4.7	9	14	19	22	25	
2	50	2500	0.25	6.4	0.8	20.3	0.05	0.08	0.11	0.18	0.3	0.5	0.8	1.1	1.5	1.7	
			0.375	9.5	0.8	20.3	0.12	0.17	0.24	0.39	0.68	1.13	1.76	2.5	3.26	3.8	
			0.5	12.7	0.8	20.3	0.18	0.27	0.38	0.62	1.07	1.79	2.77	3.95	5.14	6	
			0.812	20.6	0.8	20.3	0.46	0.68	0.95	1.55	2.68	4.47	6.93	9.88	12.9	15	
			0.994	25.2	0.8	20.3	0.46	0.77	1.2	1.82	2.84	4.87	7.32	11.36	15.67	19	
			1.25	31.8	0.8	20.3	0.8	1.17	1.64	2.68	4.64	7.75	12	17.1	22.3	26	
			1.625	41.3	0.8	20.3	1.3	1.8	2.5	3.9	6.6	13	20	26	31	35	

1. Close clearance 0.75 and 1 are available in quick change trim only (Model 21114).

2. Models 21614 and 21615 available only in C_v ranges as indicated by green background.

C_v and F_L Versus Travel

Direction: FLOW-TO-OPEN (FTO)
Flow Characteristic: MODIFIED PERCENT
Rating: ASME 2500 (PN420)

Contoured Trim

Percent of Travel:							10	20	30	40	50	60	70	80	90	100	
F _L :							0.93	0.93	0.93	0.93	0.93	0.92	0.92	0.91	0.91	0.90	0.90
Valve Size		ASME Rating	Orifice Diameter		Travel		Rated C _v										
Inch	mm		Inch	mm	Inch	mm											
0.75 ⁽²⁾	20	2500	0.25	6.4	0.8	20.3	0.04	0.07	0.14	0.28	0.5	0.73	0.99	1.28	1.52	1.7	
			0.375	9.5	0.8	20.3	0.09	0.15	0.31	0.64	1.13	1.64	2.22	2.86	3.4	3.8	
			0.5	12.7	0.8	20.3	0.14	0.24	0.49	1	1.78	2.59	3.5	4.5	5.38	6	
			0.812	20.6	0.8	20.3	0.21	0.49	0.87	2.17	3.65	5.19	6.4	7.23	7.71	8	
1 ⁽²⁾	25	2500	0.25	6.4	0.8	20.3	0.04	0.07	0.14	0.28	0.5	0.73	0.99	1.28	1.52	1.7	
			0.375	9.5	0.8	20.3	0.09	0.15	0.31	0.64	1.13	1.64	2.22	2.86	3.4	3.8	
			0.5	12.7	0.8	20.3	0.14	0.24	0.49	1	1.78	2.59	3.5	4.5	5.38	6	
			0.812	20.6	0.8	20.3	0.26	0.58	1.06	2.71	4.56	6.48	8.0	9.04	9.64	10	
1.5	40	2500	0.25	6.4	0.8	20.3	0.04	0.07	0.14	0.28	0.5	0.73	0.99	1.28	1.52	1.7	
			0.375	9.5	0.8	20.3	0.09	0.15	0.31	0.64	1.13	1.64	2.22	2.86	3.4	3.8	
			0.5	12.7	0.8	20.3	0.14	0.24	0.49	1	1.78	2.59	3.5	4.5	5.38	6	
			0.812	20.6	0.8	20.3	0.29	0.52	1.07	2.18	3.86	5.62	7.6	9.77	11.65	13	
			0.994	25.2	0.8	20.3	0.41	0.71	1.48	3.01	5.34	7.78	10.53	13.53	16.13	18	
			1.25	31.8	0.8	20.3	0.68	1.55	2.66	6.77	11.4	16.2	20	22.6	24.11	25	
2 ⁽¹⁾	50	2500	0.25	6.4	0.8	20.3	0.04	0.07	0.14	0.28	0.5	0.73	0.99	1.28	1.52	1.7	
			0.375	9.5	0.8	20.3	0.09	0.15	0.31	0.64	1.13	1.64	2.22	2.86	3.4	3.8	
			0.5	12.7	0.8	20.3	0.14	0.24	0.49	1	1.78	2.59	3.5	4.5	5.38	6	
			0.812	20.6	0.8	20.3	0.34	0.59	1.23	2.51	4.45	6.48	8.77	11.28	13.44	15	
			0.994	25.2	0.8	20.3	0.43	0.75	1.56	3.18	5.64	8.21	11.11	14.28	17	19	
			1.25	31.8	0.8	20.3	0.59	1.03	2.14	4.35	7.71	11.23	15.2	19.54	23.3	26	

1. 2 inch size valve with 2 inch (50.8mm) orifice diameter is only available with quick change trim for ASME Class 150 to 600.
2. The .75 and 1 inch valves with C_v 8 is available in quick change trim only.

C_v and F_L Versus Travel

Single Stage Lo-dB / Anti-Cavitation Trim
Single Stage Cavitation Containment

Direction: FLOW-TO-OPEN (FTO) Lo-dB
FLOW-TO-CLOSE (FTC) ANTI/CAV
Flow Characteristic: LINEAR

Percent of Travel:							10	20	30	40	50	60	70	80	90	100	
F _L :							0.93	0.93	0.93	0.93	0.93	0.93	0.93	0.93	0.93	0.93	0.93
Valve Size		ASME Rating	Orifice Diameter		Travel		Rated C _v										
Inch	mm		Inch	mm	Inch	mm											
0.75 ⁽²⁾	20	150-2500	0.812	20.26	0.8	20.3	0.24	0.56	0.96	1.44	2.08	2.68	3.2	3.56	3.84	4	
							0.48	1.12	1.92	2.88	4.16	5.36	6.4	7.12	7.68	8	
1 ⁽²⁾	25	150-2500	0.812	20.26	0.8	20.3	0.24	0.56	0.96	1.44	2.08	2.68	3.2	3.56	3.84	4	
							0.48	1.12	1.92	2.88	4.16	5.36	6.4	7.12	7.68	8	
1.5	40	150-2500	1.25	31.8	0.8	20.3	0.48	1.12	1.92	2.88	4.16	5.36	6.4	7.12	7.68	8	
							0.9	2.1	3.6	5.4	7.8	10.1	12.0	13.4	14.4	15	
2	50	150-2500	1.25	31.8	0.8	20.3	0.48	1.12	1.92	2.88	4.16	5.36	6.4	7.12	7.68	8	
							0.9	2.1	3.6	5.4	7.8	10.1	12.0	13.4	14.4	15	
			1.625	41.3			1.5	3.5	6.0	9	13	16.8	20	22.3	24	25	
			2.00 ¹	50.8			1.8	4.2	7.2	10.8	15.6	20.2	24	26.8	28.8	30	
3	80	150-1500	2.00	50.8	1.5	38.1	1.8	4.2	7.2	10.8	15.6	20.2	24	26.8	28.8	30	
			2.625	66.7			2.9	6.7	11.5	17.3	24.9	32.2	38.4	42.7	46.1	48	
			4.5	10.5			18	27	39	50.3	60	66.8	72	75			
4	100	150-1500	2.00	50.8	1.5	38.1	1.8	4.2	7.2	10.8	15.6	20.2	24	26.8	28.8	30	
			2.625	66.7			3.8	8.8	15.1	22.7	32.8	42.2	50.4	56.1	60.5	63	
			3.50	88.9			6	14	24	36	52	67	80	89	96	100	
6	150	150-600	5.00	127.0	2	50.4	9	21	36	54	78	101	120	134	144	150	
							12	28	48	72	104	134	160	178	192	200	
8	200	150-600	6.25	157.8	2.5	63.5	18	31	65	98	120	161	196	228	263	290	

1. 2 inch size valve with 2 inch (50.8mm) orifice diameter is only available with quick change trim for ASME Class 150 to 600.
2. The .75 and 1 inch valves with Cv 8 is available in quick change trim only.

C_v and F_L Versus Travel

Double Stage Anti-Cavitation Trim⁽¹⁾

Direction: FLOW-TO-CLOSE (FTC)
Flow Characteristic: LINEAR

Percent of Travel:							10	20	30	40	50	60	70	80	90	100	
F _L :							0.975	0.975	0.975	0.975	0.975	0.975	0.975	0.975	0.975	0.975	0.975
Valve Size		ASME Rating	Orifice Diameter		Travel		Rated C _v										
inch	mm		inch	mm	inch	mm											
0.75	20	150-2500	0.812	20.6	0.8	20.3	0.14	0.32	0.55	0.83	1.2	1.54	1.8	2.1	2.2	2.3	
							0.27	0.63	1.08	1.62	2.3	3	3.6	4	4.3	4.5	
1	25	150-2500	0.812	20.6	0.8	20.3	0.14	0.32	0.55	0.83	1.2	1.54	1.8	2.1	2.2	2.3	
							0.27	0.63	1.08	1.62	2.3	3	3.6	4	4.3	4.5	
1.5	40	150-2500	0.812	20.6	0.8	20.3	0.14	0.32	0.55	0.83	1.2	1.54	1.8	2.1	2.2	2.3	
							0.27	0.63	1.08	1.62	2.3	3	3.6	4	4.3	4.5	
			1.25	31.8	0.8	20.3	0.51	1.19	2	3.1	4.4	5.7	6.8	7.6	8.2	8.5	
2	50	150-2500	1.25	31.8	0.8	20.3	0.27	0.63	1.08	1.62	2.3	3	3.6	4	4.3	4.5	
							0.51	1.19	2	3.1	4.4	5.7	6.8	7.6	8.2	8.5	
			1.625	41.3	0.8	20.3	0.8	1.9	3.4	5	7.3	9.4	11.2	12.5	13.4	14	
3	80	150-1500	2.625	66.7	1.5	38.1	1.6	3.8	6.4	9.7	14.1	18.1	21.6	24	25.9	27	
							2.5	5.9	10.1	15.1	21.8	28.1	33.6	37.4	40.3	42	
4	100	150-1500	2.625	66.7	1.5	38.1	2.4	5.6	9.6	14.4	20.8	26.8	32	35.6	38.4	40	
							3.5	88.9	3.7	8.7	14.9	22.3	32.2	41.5	49.6	55.2	59.5

1. Double stage anti-cavitation trim not available with Bellows Seal construction.

Double Stage Lo-dB Trim⁽¹⁾

Direction: FLOW-TO-OPEN (FTO)
Flow Characteristic: LINEAR

Percent of Travel:							10	20	30	40	50	60	70	80	90	100	
F _L :							0.95	0.95	0.95	0.95	0.95	0.95	0.95	0.95	0.95	0.95	0.95
Valve Size		ASME Rating	Orifice Diameter		Travel		Rated C _v										
inch	mm		inch	mm	inch	mm											
0.75	20	150-2500	0.812	20.6	0.8	20.3	0.21	0.49	0.84	1.26	1.8	2.4	2.8	3.1	3.4	3.5	
							0.34	0.8	1.37	2.1	3	3.8	4.6	5.1	5.5	5.7	
1	25	150-2500	0.812	20.6	0.8	20.3	0.21	0.49	0.84	1.26	1.8	2.4	2.8	3.1	3.4	3.5	
							0.34	0.8	1.37	2.1	3	3.8	4.6	5.1	5.5	5.7	
1.5	40	150-2500	1.25	31.8	0.8	20.3	0.42	0.98	1.68	2.5	3.6	4.7	5.6	6.2	6.7	7	
							0.8	1.8	3.1	4.7	6.8	8.7	10.4	11.6	12.5	13	
2	50	150-2500	1.25	31.8	0.8	20.3	0.8	1.8	3.1	4.7	6.8	8.7	10.4	11.6	12.5	13	
							1.3	2.9	5	7.6	10.9	14.1	16.8	18.7	20.2	21	
3	80	150-1500	2.625	66.7	1.5	38.1	2.4	5.6	9.6	14.4	20.8	26.8	32	35.6	38.4	40	
							3.5	88.9	1.5	38.1	3.8	8.8	15.1	22.7	32.8	42.2	50.4
4	100	150-1500	2.625	66.7	1.5	38.1	3.2	7.4	12.7	19.1	27.6	35.5	42.4	47.2	50.9	53	
							3.5	88.9	1.5	38.1	4.9	11.6	19.9	29.9	43.2	55.6	66.4
6	150	150-600	3.5	88.9	1.5	38.1	7.5	17.5	30	45	65	84	100	111	120	125	

1. Double stage anti-cavitation trim not available with Bellows Seal construction.

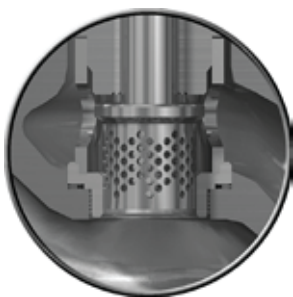

Single Stage Lo-dB /
Anti-Cavitation Trim

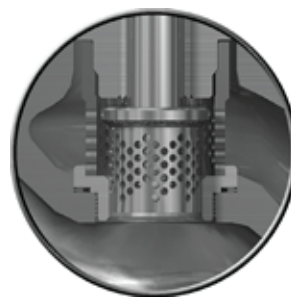

Double Stage Lo-dB /
Anti-Cavitation Trim

Materials of Construction

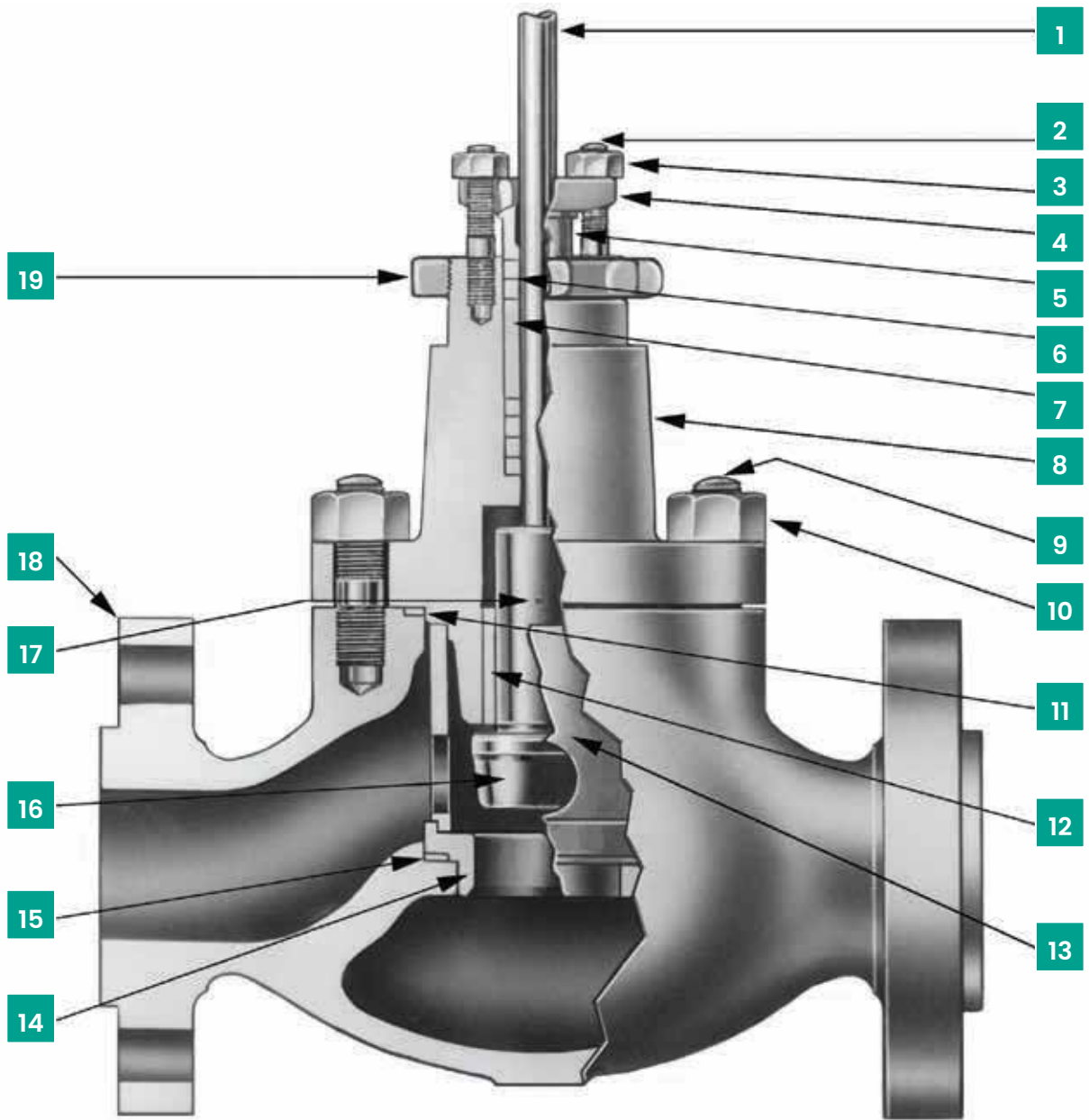

Standard Construction

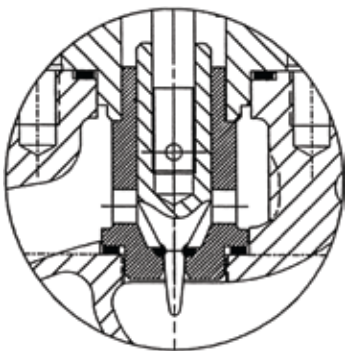

21000 Close Clearance
Low Flow Trim

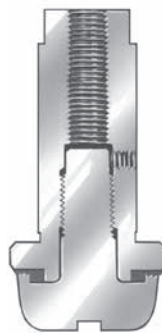

Soft Seated
Plug S/A

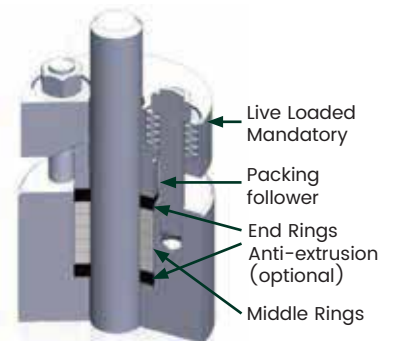

LE Packing System (Optional)
Low Emission Stem Packing

- Live Loaded Mandatory
- Packing follower
- End Rings Anti-extrusion (optional)
- Middle Rings

Materials of Construction

Standard Carbon Steel Version

Ref . No.	Temperature Range	-20°F (-29°C)	450°F (232°C)	650°F (343°C)	800°F (427°C)	
		Standard Materials				
1	Plug Stem	17-4 PH STAINLESS STEEL H1075 ¹				
		SOLUTION ANNEALED 316 STAINLESS STEEL				
		HARDENED ASTM A638 GRADE 660				
		ASTM B637 ALLOY				
2	Packing Flange Stud	ASTM A193 GRADE B8 CLASS 1				
3	Packing Flange Nut	ASTM A194 GRADE 8				
4	Packing Flange	LOW CARBON STEEL ZINC PLATED				
5	Packing Follower	SOLUTION ANNEALED 316L STAINLESS STEEL				
6	Packing	PTFE PACKING / LE PACKING		FLEXIBLE GRAPHITE PACKING		
		CARBON CORE BRAIDED PTFE PACKING WITH EXTENSION BONNET				
7	Lantern Ring (Optional)	AUSTENITIC STAINLESS STEEL				
8	Valve Bonnet	ASTM A216 GRADE WCC/WCB/EN 1.0619/1.0625 or A105				
9	Body Stud	ASTM A193 GRADE B7				
10	Body Stud Nut	ASTM A194 GRADE 2H				
11	Body Gasket	316L ST ST SPIRAL WOUND GASKET WITH GRAPHITE FILLER				
12	Guide Bushing ⁶	HARDENED 440C STAINLESS STEEL ²				
		Stellite or Equivalent NO. 6				
13	Cage / Retainer ⁴	SOLUTION ANNEALED 304 STAINLESS STEEL				
		CA6NM CLASS B STAINLESS STEEL ³				
	Close Clearance Cage/Seat	SOLUTION ANNEALED 316 STAINLESS STEEL				
		HARDENED 410 STAINLESS STEEL				
Stellite or Equivalent NO. 6						
14	Seat Ring	SOLUTION ANNEALED 316 STAINLESS STEEL				
		HARDENED 410 STAINLESS STEEL				
		316 STAINLESS STEEL WITH Stellite or Equivalent NO. 6 HARDFACING				
		HARDENED 440C STAINLESS STEEL (from 0.75" to 3" only)				
15	Seat Ring Gasket	316L ST ST SPIRAL WOUND GASKET WITH GRAPHITE FILLER				
16	Plug	SOLUTION ANNEALED 316 STAINLESS STEEL				
		SOLUTION ANNEALED 316 SS W/ TEFLON [®] SEAT				
		HARDENED 410 STAINLESS STEEL				
		316 STAINLESS STEEL WITH Stellite or Equivalent NO. 6 HARDFACING ON SEAT ⁵				
		316 STAINLESS STEEL WITH Stellite or Equivalent NO. 6 HARDFACING ON SEAT AND GUIDE ⁵				
	Stellite or Equivalent NO. 6 ⁷					
	Close Clearance Plug	Stellite or Equivalent NO. 6 ⁷				
17	Plug Pin	SOLUTION ANNEALED 316 STAINLESS STEEL				
18	Valve Body	ASTM A216 GRADE WCC/WCB / EN 1.0619/1.0625				
19	Drive Nut	LOW CARBON STEEL GRADES DICHROMATE ZINC PLATED				

1. 17-4 PH ST.ST will be substituted when required due to the differential pressure.
2. 440C bushing not used in combination with 316 trim.
3. Standard material for two stage lo-db (drilled hole) cages.
4. Required for Quick Change trim only.

5. Use Solid Stellite or Equivalent plug for C_v smaller than 1.7.
6. Guide bushings not used with close clearance trim.
7. Solid Stellite or Equivalent is not available for Lo-dB/Anti-Cavitation plugs.

Materials of Construction

Standard Stainless Steel Version

Ref . No.	Temperature Range	-20°F (-29°C)	450°F (232°C)	650°F (343°C)	800°F (427°C)
	Description	Standard Materials			
1	Plug Stem	SOLUTION ANNEALED 316 STAINLESS STEEL			
		HARDENED ASTM A638 GRADE 660			
		ASTM B637 ALLOY			
2	Packing Flange Stud	ASTM A193 GRADE B8 CLASS 1			
3	Packing Flange Nut	ASTM A194 GRADE 8			
4	Packing Flange	ASTM A216 GRADE WCC ZINC PLATING			
5	Packing Follower	AUSTENITIC STAINLESS STEEL			
6	Packing	PTFE PACKING / LE PACKING		FLEXIBLE GRAPHITE PACKING	
		PTFE PACKING / LE PACKING WITH EXTENSION BONNET			
7	Lantern Ring (Optional)	AUSTENITIC STAINLESS STEEL			
8	Valve Bonnet	ASTM A351 GRADE CF8M			
9	Body Stud	ASTM A193 GR B7 – ZINC PLATING		ASTM A193 GRADE B7	
10	Body Stud Nut	ASTM A194 GR 2H – ZINC PLATING		ASTM A194 GRADE 2H	
11	Body Gasket	316L ST ST SPIRAL WOUND GASKET WITH GRAPHITE FILLER			
12	Guide Bushing ⁴	NITRONIC 60 ASTM A479			
		Stellite or Equivalent NO. 6			
13	Cage / Retainer ¹	SOLUTION ANNEALED 304 STAINLESS STEEL			
		CA6NM CLASS B STAINLESS STEEL ²			
	Close Clearance Cage/Seat	SOLUTION ANNEALED 316 STAINLESS STEEL			
		HARDENED 410 STAINLESS STEEL			
		Stellite or Equivalent NO. 6			
14	Seat Ring	SOLUTION ANNEALED 316 STAINLESS STEEL			
		316 STAINLESS STEEL WITH Stellite or Equivalent NO. 6 HARDFACING			
15	Seat Ring Gasket	316L ST ST SPIRAL WOUND GASKET WITH GRAPHITE FILLER			
16	Plug	SOLUTION ANNEALED 316 STAINLESS STEEL			
		SOLUTION ANNEALED 316 SS W/ TEFLON [®] SEAT			
		HARDENED 410 STAINLESS STEEL			
		316 STAINLESS STEEL WITH Stellite or Equivalent NO. 6 HARDFACING ON SEAT ³			
		316 STAINLESS STEEL WITH Stellite or Equivalent NO. 6 HARDFACING ON SEAT AND GUIDE ⁴			
	Stellite or Equivalent NO. 6 ⁵				
	Close Clearance Plug	Stellite or Equivalent NO. 6 ⁵			
17	Plug Pin	SOLUTION ANNEALED 316 STAINLESS STEEL			
18	Valve Body	ASTM A351 GRADE CF8M			
19	Drive Nut	ASTM A216 GRADE WCC			
Ref . No.	Temperature Range	-20°F (-29°C)	450°F (232°C)	650°F (343°C)	800°F (427°C)

1. Required for Quick Change trim only.

2. Standard material for two stage lo-db (drilled hole) cages.

3. Use Solid Stellite or Equivalent plug for Cv smaller than 1.7.

4. Guide bushings not used with close clearance trim.

5. Solid Stellite or Equivalent is not available for Lo-dB/Anti-Cavitation plugs.

Materials of Construction

Standard Chrome Moly Version

Ref . No.	Temperature Range	-20°F (-29°C)	450°F (232°C)	650°F (343°C)	800°F (427°C)	
	Description	Standard Materials				
1	Plug Stem	17-4 PH STAINLESS STEEL H1075				
		SOLUTION ANNEALED 316 STAINLESS STEEL				
		HARDENED ASTM A638 GRADE 660				
		ASTM B637 ALLOY				
2	Packing Flange Stud	ASTM A193 GRADE B8 CLASS 1				
3	Packing Flange Nut	ASTM A194 GRADE 8				
4	Packing Flange	ASTM A216 GRADE WCC ZINC PLATING				
5	Packing Follower	AUSTENITIC STAINLESS STEEL				
6	Packing	PTFE PACKING / LE PACKING		FLEXIBLE GRAPHITE PACKING		
		PTFE PACKING / LE PACKING WITH EXTENSION BONNET				
7	Lantern Ring (Optional)	AUSTENITIC STAINLESS STEEL				
8	Valve Bonnet	ASTM A217 GRADE WC9 CLASS 3				
9	Body Stud	ASTM A193 GRADE B7				
10	Body Stud Nut	ASTM A194 GRADE 2H				
11	Body Gasket	316L ST ST SPIRAL WOUND GASKET WITH GRAPHITE FILLER				
12	Guide Bushing ⁵	HARDENED 440C STAINLESS STEEL				
		Stellite or Equivalent NO. 6				
13	Cage / Retainer ²	SOLUTION ANNEALED 304 STAINLESS STEEL				
		CA6NM CLASS B STAINLESS STEEL ³				
	Close Clearance Cage/Seat	SOLUTION ANNEALED 316 STAINLESS STEEL				
HARDENED 410 STAINLESS STEEL						
Stellite or Equivalent NO. 6						
14	Seat Ring	SOLUTION ANNEALED 316 STAINLESS STEEL				
		HARDENED 410 STAINLESS STEEL				
		316 STAINLESS STEEL WITH Stellite or Equivalent NO. 6 HARDFACING				
15	Seat Ring Gasket	316L ST ST SPIRAL WOUND GASKET WITH GRAPHITE FILLER				
16	Plug	SOLUTION ANNEALED 316 STAINLESS STEEL				
		SOLUTION ANNEALED 316 SS W/ TEFLON [®] SEAT				
		HARDENED 410 STAINLESS STEEL				
		316 STAINLESS STEEL WITH Stellite or Equivalent NO. 6 HARDFACING ON SEAT ⁴				
		316 STAINLESS STEEL WITH Stellite or Equivalent NO. 6 HARDFACING ON SEAT AND GUIDE ⁴				
	Stellite or Equivalent NO. 6 ⁶					
	Close Clearance Plug	Stellite or Equivalent NO. 6 ⁶				
17	Plug Pin	SOLUTION ANNEALED 316 STAINLESS STEEL				
18	Valve Body	ASTM A217 GRADE WC9 CLASS 3				
19	Drive Nut	ASTM A216 GRADE WCC				

1. 17-4 PH ST.ST will be substituted when required due to the differential pressure.

2. Required for Quick Change trim only.

3. Standard material for two stage Lo-db (drilled hole) cages.

4. Use Solid Stellite or Equivalent plug for Cv smaller than 1.7.

5. Guide bushings not used with close clearance trim.

6. Solid Stellite or Equivalent is not available for Lo-db/Anti-Cavitation plugs.

Materials of Construction

NACE Materials Construction

Ref. No.	Temperature Range	-50°F (-46°C)	-20°F (-29°C)	450°F (232°C)	
		NACE Materials ¹			
Description					
1	Plug Stem ⁸	SOLUTION ANNEALED 316 STAINLESS STEEL			
		ASTM B637 ALLOY UNS NO7750 ²			
		SOLUTION ANNEALED 316L STAINLESS STEEL			
2	Packing Flange Stud	ASTM A194 GRADE 8			
3	Packing Flange Nut	ASTM A194 GRADE 8			
4	Packing Flange	LOW CARBON STEEL ZINC PLATED			
5	Packing Follower	SOLUTION ANNEALED 316L STAINLESS STEEL			
6	Packing	CARBON CORE BRAIDED PTFE PACKING			
7	Lantern Ring (Optional)	SOLUTION ANNEALED 304 STAINLESS STEEL			
8	Valve Bonnet	ASTM A216 GRADE WCC/WCB / EN 1.0619/1.0625			
		ASTM A105 / 1.0436 EN 10222-2			
		ASTM A351 GRADE CF8M / EN 1.4408			
9	Body Stud	ASTM A193 GR B7 – ZINC PLATING ^{3,7}			
		ASTM A193 GR B7M ZINC PLATING ^{4,7}			
		ASTM A193 GRADE B7 ³			
		ASTM A193 GRADE B7M ⁴			
10	Body Stud Nut	ASTM A194 GR 2H – ZINC PLATING ^{3,7}			
		ASTM A194 GR 2HM ZINC PLATING ^{4,7}			
		ASTM A194 GRADE 2H ³			
		ASTM A194 GRADE 2HM ⁴			
11	Body Gasket	316L ST ST SPIRAL WOUND GASKET WITH GRAPHITE FILLER			
12	Guide Bushing ⁶	Stellite or Equivalent NO. 6			
13	Cage / Retainer ⁴	SOLUTION ANNEALED 304 STAINLESS STEEL			
	Close Clearance Cage/Seat	SOLUTION ANNEALED 316 STAINLESS STEEL Stellite or Equivalent NO. 6			
14	Seat Ring	SOLUTION ANNEALED 316 STAINLESS STEEL			
		316 STAINLESS STEEL WITH Stellite or Equivalent NO. 6 HARDFACING			
15	Seat Ring Gasket	316L ST ST SPIRAL WOUND GASKET WITH GRAPHITE FILLER			
16	Plug	SOLUTION ANNEALED 316 STAINLESS STEEL			
		316 STAINLESS STEEL WITH Stellite or Equivalent NO. 6 HARDFACING ON SEAT			
		316 STAINLESS STEEL WITH Stellite or Equivalent NO. 6 HARDFACING ON SEAT AND GUIDE Stellite or Equivalent NO. 6 ^{6,9}			
	Close Clearance Plug	Stellite or Equivalent NO. 6 ^{6,9}			
17	Plug Pin	SOLUTION ANNEALED 316 STAINLESS STEEL			
18	Valve Body	ASTM A216 GRADE WCC/WCB / EN 1.0619/1.0625			
		ASTM A105 / 1.0436 EN 10222-2			
		ASTM A351 GRADE CF8M / EN 1.4408			
19	Drive Nut	ASTM A216 GRADE WCC			

- Materials and processes in accordance with the requirements of NACE specification MR0103. Applications requiring compliance to MR0175, 2003 Rev. or ISO 15156 would require engineering review.
- Inconel 718 will be substituted in applications when required due to the differential pressure.
- Materials designated for these parts conform to NACE non-exposed bolting requirements.
- Materials designated for these parts conform to NACE exposed bolting requirements.

- Consult Masoneilan for NACE Applications above ANSI Class 600 (PN 100) rating or above 450°F (232°C).
- Optional component and materials for Close Clearance low flow trim option.
- To be used with stainless steel body and bonnet.
- Guide bushing not used with close clearance trim.
- Solid Stellite or Equivalent is not available for Lo-dB/Anti-Cavitation plugs.

Materials of Construction

Cryogenic Construction

Ref. No.	Temperature Range	-320°F (-196°C)	-50°F (-46°C)	-20°F (-29°C)
	Description ^{3,4}	Standard Materials ^{1,2,5}		
1	Plug Stem	SOLUTION ANNEALED 316 STAINLESS STEEL		
		HARDENED ASTM A638 GRADE 660		
2	Packing Flange Stud	ASTM A193 GRADE B8 CLASS 1		
3	Packing Flange Nut	ASTM A194 GR 8		
4	Packing Flange	ASTM A351 GRADE CF8M		
5	Packing Follower	SOLUTION ANNEALED 316L STAINLESS STEEL		
6	Packing	TEFLON™ V-Ring		
7	Lantern Ring (Optional)	AUSTENITIC STAINLESS STEEL		
8	Valve Bonnet	ASTM A351 GRADE CF8M / EN 1.4408		
		ASTM A479 TYPE 316		
		ASTM A312 TYPE 316		
9	Body Stud ⁶	ASTM A193 GRADE B8 CLASS 2 (for studs ≤ Ø 3/4") 0.75" ; 1" ; 1.5" ; 2" ; 3" => 150/300/600 lb 4" ; 6" => 150/300 lb		
		ASTM A453 GRADE 660 CLASS A for studs > 3/4" 0.75" ; 1" ; 1.5" & 2" => 900/1500/2500 lb 3" => 900/1500 lb - 4" => 600/900/1500 lb 6" => 600 lb - 8" => 150/300/600 lb		
		ASTM A194 GR 8		
		ASTM A194 GR 8		
10	Body Stud Nut	ASTM A194 GR 8		
11	Body Gasket	316L ST ST SPIRAL WOUND GASKET WITH GRAPHITE FILLER		
12	Guide Bushing ⁶	STELLITE NO.6 (UNS 30006)(STANDARD)		
		ASTM A479 UNS S21800 (OPTIONAL)		
13	Cage	SOLUTION ANNEALED 304 STAINLESS STEEL (STANDARD)		
		SOLUTION ANNEALED 316 STAINLESS STEEL (OPTIONAL)		
		ASTM A479 TYPE 316		
14	Seat Ring	SOLUTION ANNEALED 316 STAINLESS STEEL (STANDARD)		
		HARDFACING STELLITE NO.6 ON 316 STAINLESS STEEL		
15	Seat Ring Gasket	316L ST ST SPIRAL WOUND GASKET WITH GRAPHITE FILLER		
16	Plug	SOLUTION ANNEALED 316 STAINLESS STEEL (STANDARD)		
		HARDFACING STELLITE NO.6 ON 316 STAINLESS STEEL		
17	Plug Pin	SOLUTION ANNEALED 316 STAINLESS STEEL		
18	Valve Body	ASTM A351 GRADE CF8M / EN 1.4408		
19	Drive Nut	LOW CARBON STEEL GRADES DICHROMATE ZINC PLATED		

1. Materials recommended for Cryogenic Liquid Natural Gas (LNG) applications -320°F (-196°C). Consult factory for suitability in their cryogenic applications.
2. Consult factory for NACE applications.
3. Trim offerings limited to Quick Change designs only.
4. Consult factory for proper actuator sizing to provide correct valve shut-off.
5. JIS and EN material equivalents are available.

Bellows seal design features 21000 BS Series

Standard construction

Bellows seal configuration is fully compatible with the standard 21000 Series trim and actuator options providing equivalent capacity capabilities for each valve size. The standard packing box design and packing design options are used as a secondary stem seal.

Rugged design

The formed bellows construction is an externally pressurized design that is capable of operating up to the full valve ANSI B16.34 pressure rating. Guides are located above and below the bellows providing excellent stability to withstand flow induced and mechanical vibration.

Extended life

The bellows assembly is designed for 50% compression/extension (zero stress) at the valve mid-stroke position to help maximize cycle life. Bellows torsional stresses are also reduced with the anti-rotation feature provided by flats on the plug stem.

High quality

Each bellows subassembly is helium leak tested to verify weld integrity, and is also hydro-statically tested as part of the complete valve assembly. Mechanical travel stops are also designed into both the bellows and valve assemblies to prevent over compression or extension.

Smart solution

Bellows installed cycle life can be monitored in the field by utilizing Masoneilan's SVI™ Digital Positioner with actual process data. This advanced preventative maintenance option will help improve plant safety by identifying potential hazardous failures before they happen, and cut cost by reducing premature bellows replacement.

Bellows materials standard material

316/316L stainless steel

Optional materials

- Hastelloy C276
- Monel 400
- Inconel 625

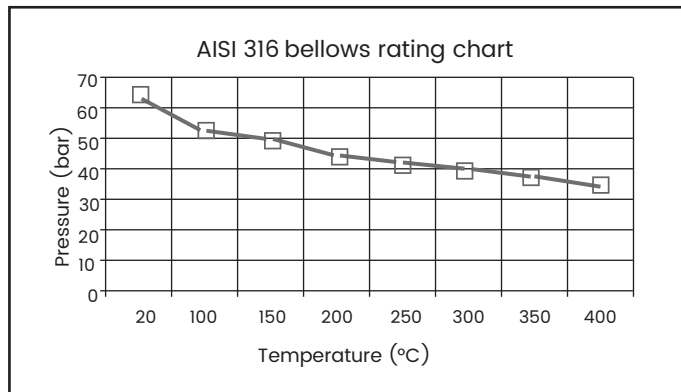

Size and ratings

Pressure ratings: ASME Class 150 and 300 – PN 20 and PN 50

Valve size	Bellows design stroke		Life cycle ratings ¹		
	Inches	mm	100%	50%	25%
.75" - 2"	75	19	100,000 Full Cycles	600,000 Full Cycles	3,000,000 Full Cycles
3" - 4"	1.50	38.1			
6"	2.00	50.8			

1. Minimum expected average cycle life for Class 300 (PN50) bellows operating at constant pressure.
 2. Consult Masoneilan for Bellows applications above ASME Class 300 (PN50).

Materials of construction

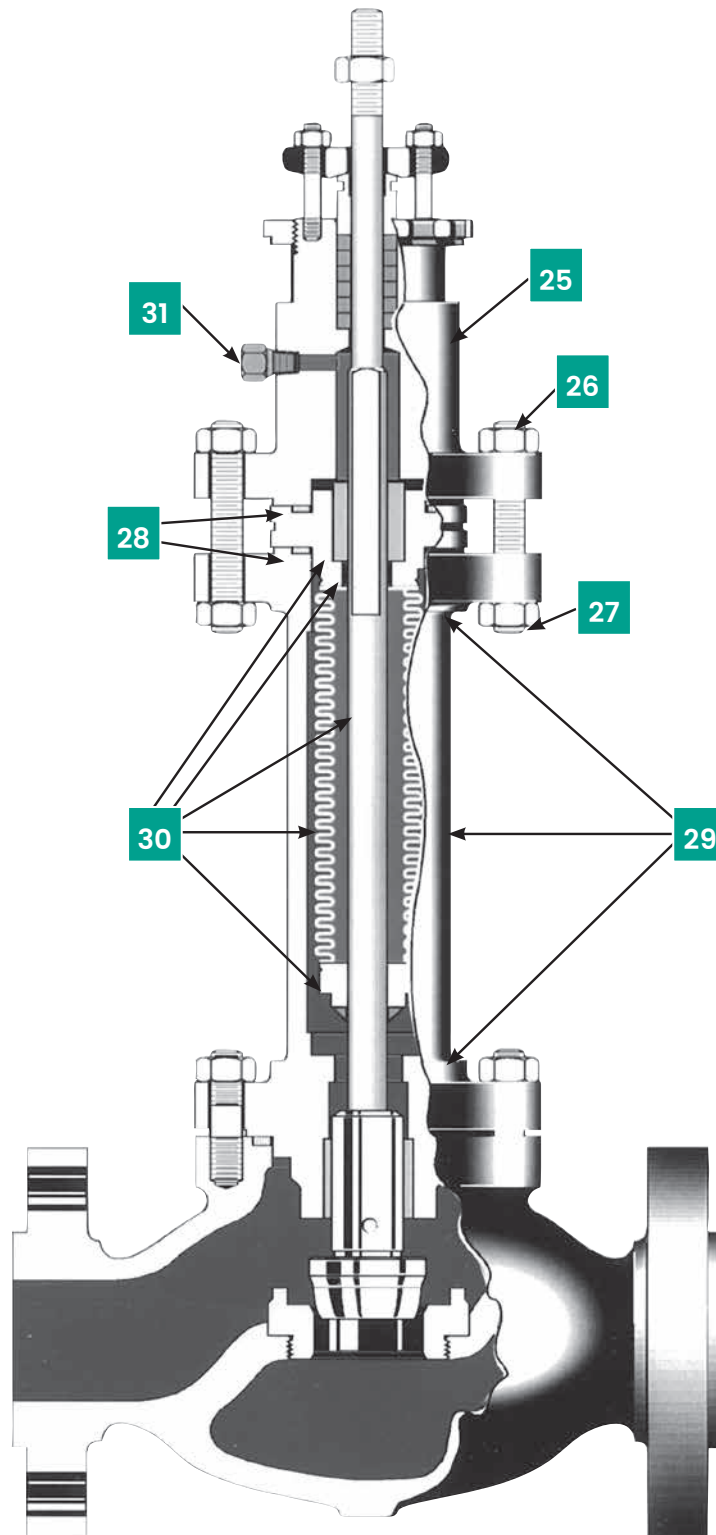

Bellows seal construction

Materials of construction

Bellows Seal – Carbon Steel Body Version

Ref. No.	Temperature Range		
		-20°F (-29°C)	800°F (427°C)
Ref. No.	Description	Materials	
25	Valve Bonnet	ASTM A216 GRADE WCC/WCB or ASTM A105	
26	Bonnet Stud	ASTM A193 GRADE B7	
27	Bonnet Stud Nut	ASTM A194 GRADE 2H	
28	Bonnet Spacer Gasket	316L ST ST SPIRAL WOUND GASKET WITH GRAPHITE FILLER	
29	Carbon Steel Bonnet Extension Assembly	Upper Flange	ASTM A216 GRADE WCC or ASTM A105
		Spacer	ASTM A106 GRADE B HRC 22 MAXIMUM
		Lower Flange	ASTM A216 GRADE WCC
30	Stainless Steel Bellows and Stem Assembly	Stem	SOLUTION ANNEALED 316 STAINLESS STEEL
		Guide Bushing	ASTM A479
		Bellows	316 ST. ST. ASTM A240/A312
		Upper Adapter Lower Adapter	GENERAL SERVICE ANNEALED 316L ST ST
	Hastelloy C Bellows and Stem Assembly	Stem	ASTM B574
		Guide Bushing	Stellite or Equivalent NO. 6
		Bellows	Hastelloy C276 ASTM B575/B622
		Upper Adapter Lower	ASTM B574
	Monel 400 ³ Bellows and Stem Assembly	Stem	ASTM B164 CLASS A
		Guide Bushing	Stellite or Equivalent NO. 6
		Bellows	ASTM B164 CLASS A
		Upper Adapter Lower	ASTM B164 CLASS A
Inconel 625 ³ Bellows and Stem Assembly	Stem	INCONEL X-750	
	Guide Bushing	Stellite or Equivalent NO. 6	
	Bellows	ASTM B446	
	Upper Adapter Lower	ASTM B446	
31	Plug – 1/8" NPT	ASTM A234 GRADE WPB	
Ref. No.	Temperature Range		
		-20°F (-29°C)	800°F (427°C)

1. Materials for other components are same as listed for Standard Carbon Steel Construction.
2. Items No. 1 (plug stem) and 8 (bonnet) in Standard Materials of Construction tables are replaced by items above.
3. Optional Hastelloy C, Monel 400 and Inconel 625 Bellows Construction available.

Materials of Construction

Bellows Seal – Stainless Steel Body Version

Ref . No.	Temperature Range		-20°F (-29°C)	650°F (343°C)	800°F (427°C)
	Description	Materials			
25	Valve Stud		ASTM A351 GRADE CF8M or ASTM A182 GRADE F 316		
26	Bonnet Stud		ASTM A193 GR B7 – ZINC PLATING	ASTM A193 GRADE B7	
27	Bonnet Stud Nut		ASTM A194 GR 2H – ZINC PLATING	ASTM A194 GRADE 2H	
28	Bonnet Spacer Gasket		316L ST ST SPIRAL WOUND GASKET WITH GRAPHITE FILLER		
29	Carbon Steel Bonnet Extension Assembly	Upper Flange	ASTM A351 GRADE CF8M or ASTM A182 GRADE F 316		
		Spacer	316 St. St. ASTM A269 TY 316		
		Lower Flange	ASTM A351 GRADE CF8M		
30	Stainless Steel Bellows and Stem Assembly	Stem	SOLUTION ANNEALED 316 STAINLESS STEEL		
		Guide Bushing	ASTM A479		
		Bellows	316 St. St. ASTM A240/A312		
		Upper Adapter Lower Adapter	GENERAL SERVICE ANNEALED 316L ST ST		
	Hastelloy C ³ Bellows and Stem Assembly	Stem	ASTM B574		
		Guide Bushing	Stellite or Equivalent NO. 6		
		Bellows	Hastelloy C276 ASTM B575/B622		
		Upper Adapter Lower	ASTM B574		
	Monel 400 ³ Bellows and Stem Assembly	Stem	ASTM B164 CLASS A		
		Guide Bushing	Stellite or Equivalent NO. 6		
		Bellows	ASTM B164 CLASS A		
		Upper Adapter Lower	ASTM B164 CLASS A		
Inconel 625 ³ Bellows and Stem Assembly	Stem	INCONEL X-750			
	Guide Bushing	Stellite or Equivalent NO. 6			
	Bellows	ASTM B446			
	Upper Adapter Lower	ASTM B446			
31	Plug – 1/8" NPT		AUSTENITIC STAINLESS STEEL		

1. Materials for other components are same as listed for Standard Stainless Steel Construction.
2. Items No. 1 (plug stem) and 8 (bonnet) in Standard Materials of Construction tables are replaced by items above.
3. Optional Hastelloy C, Monel 400 and Inconel 625 Bellows Construction available.

High Pressure Design Features

API 6A 21000 Series

API 6A 21000 Series Valve is offered from 0.75 to 1 inch, with API class 10 kPSI [690 bar] to 15 kPSI [1034 bar].

This design consists of a single ported, cage guided control valve designed to meet API 6A standards for high pressure applications:

Forged Body

Forged bodies will meet 15 kPSI (1034 bar) in operation.

Integral Bonnet

Designed with an integral bonnet, the API 6A 21000 Series Valve has a smaller profile and reduced weight.

Integral Internal Components

Seat and cage are one piece allowing for ease of installation and maintenance.

Flow Characteristic

Linear characteristic is standard.

Trim Options

Full area and reduced trims are available for optimal control.

Leakage Rate

Class IV & V leakage is standard as per IEC-60534-4.

Hardened Trim

For longer service life, hardened trim is provided to handle high pressure.

Packing

Standard packing and environmental LOW E packing options are available to comply with application requirements.

NACE Compliance

NACE MRO175/ISO 15156-1 compatible materials are available.

Size and ratings

Pressure ratings: API class from 10 kPSI [690 bar] to 15 kPSI [1034 bar]

End Connections and Shut Off

Valve Size (in)	Valve Ends Size (NPS)	Body Rating	Packing Material	Seat Type	Temperature Range								Seat Leakage Class IEC 60534-4 / ANSI / FCI 70-2	
					Stainless Steel F6NM		Duplex Stainless Steel F51		Duplex Stainless Steel F55		Inconel 718™			
					Min.	Max.	Min.	Max.	Min.	Max.	Min.	Max.		
0.75 to 1 ^{1,2,3}	1 ¹³ / ₁₆ (1.8125)	API 10K API 15K	PTFE	Metal	-75°F (-60°C)	+350°F (+180°C)	-50°F (-46°C)	+350°F (+180°C)	-50°F (-46°C)	+350°F (+180°C)	-75°F (-60°C)	+350°F (+180°C)	IV	V

1. Pressure drop is limited at 10 kPSI [690 bar] for the 15 kPSI [1034 bar] valve.

2. API 6A 21000 valves are designed as control valves, not as isolating valves.

3. Lifting lugs are provided for handling.

C_v and F_L Versus Travel

API 6A 21000 Series

Direction: **FLOW-TO-OPEN (FTO)**
Flow Characteristic: **LINEAR**

API 10K & 15K – FTO Models 21114

Sizes: 3/4" through 1" Contoured API 10K & 15K – Flow to Close																
Travel (Percent)							10	20	30	40	50	60	70	80	90	100
FL							0.93	0.93	0.92	0.91	0.91	0.91	0.91	0.90	0.90	0.90
Valve Size	Valve Ends Size	API 6A Rating	Orifice Dia.		Travel		Rated Cv									
			inch	mm	inch	mm										
inch	mm		inch	mm	inch	mm										
0.75	1"13/16	10000 & 15000	0.25	6.35	0.8	20.32	0.07	0.21	0.33	0.44	0.55	0.64	0.74	0.84	0.94	1
			0.25	6.35	0.8	20.32	0.22	0.34	0.47	0.65	0.85	1.03	1.20	1.39	1.60	1.7
			0.375	9.53	0.8	20.32	0.81	1.41	1.91	2.32	2.69	2.99	3.24	3.48	3.75	3.8
1	1"13/16	10000 & 15000	0.50	12.70	0.8	20.32	1.03	1.78	2.49	3.14	3.74	4.28	4.88	5.64	6.43	6
			0.812	20.64	0.8	20.32	2.28	3.85	5.31	6.60	7.66	8.96	10.24	11.04	11.57	12

Direction: **FLOW-TO-CLOSE (FTC)**
Flow Characteristic: **LINEAR**

API 10K & 15K – FTC Models 21114

Sizes: 3/4" through 1" Contoured API 10K & 15K – Flow to Close																
Travel (Percent)							10	20	30	40	50	60	70	80	90	100
FL							0.53	0.56	0.60	0.68	0.75	0.78	0.81	0.84	0.85	0.86
Valve Size	Valve Ends Size	API 6A Rating	Orifice Dia.		Travel		Rated Cv									
			inch	mm	inch	mm										
inch	mm		inch	mm	inch	mm										
0.75	1"13/16	10000 & 15000	0.25	6.35	0.8	20.32	0.30	0.50	0.66	0.90	1.14	1.38	1.61	1.78	1.87	1.9
			0.375	9.53	0.8	20.32	1.07	1.86	2.42	2.75	3.15	3.58	3.85	3.99	4.17	4.2
1	1"13/16	10000 & 15000	0.50	12.70	0.8	20.32	1.20	2.25	2.97	3.46	3.83	4.27	4.88	5.87	6.94	7
			0.812	20.64	0.8	20.32	2.46	4.29	5.62	6.56	7.38	8.41	10.01	12.10	12.67	13

Materials of Construction

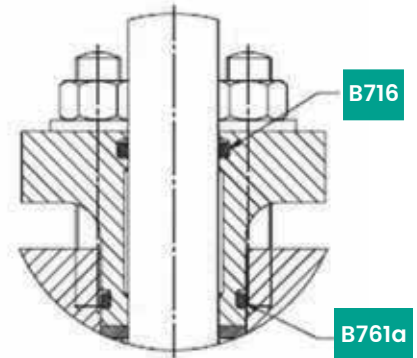
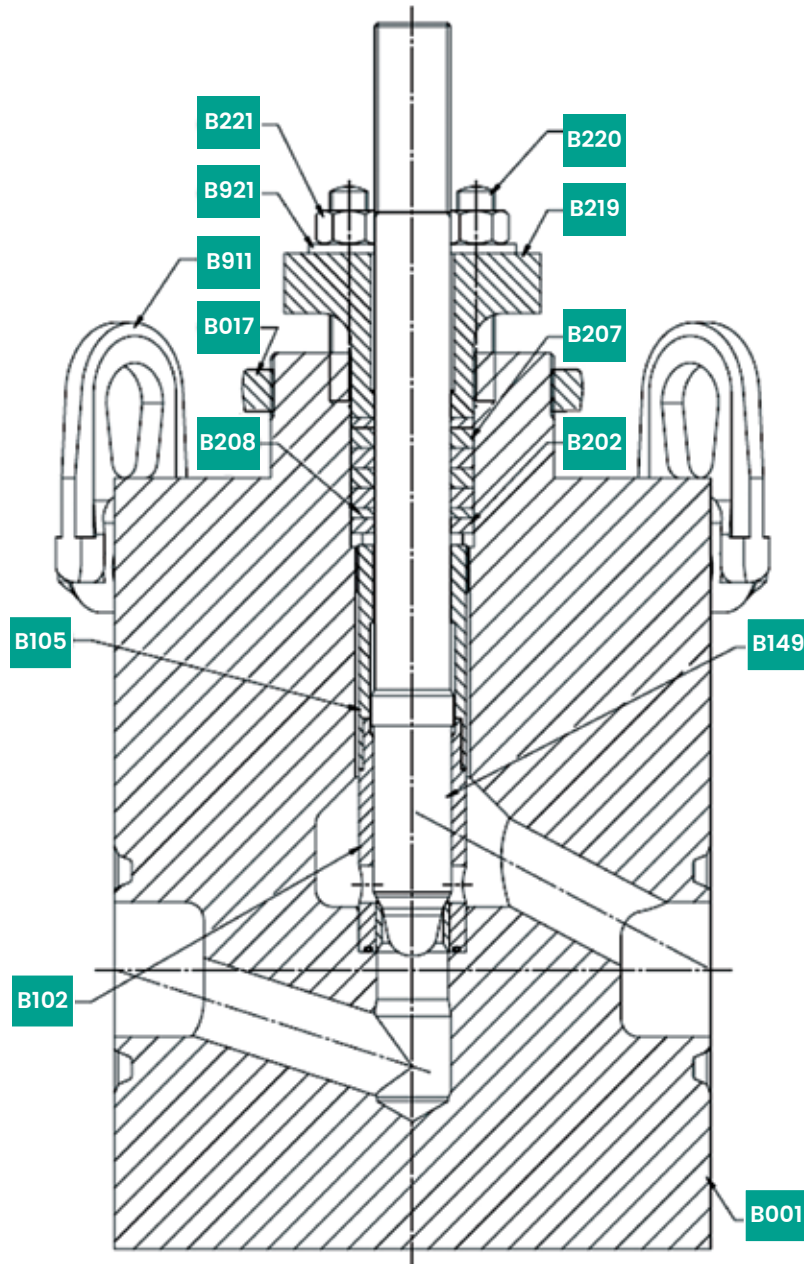

Packing Flange/Follower O-Ring Detail

Flow-to-Close Seat-Ring Gasket Detail

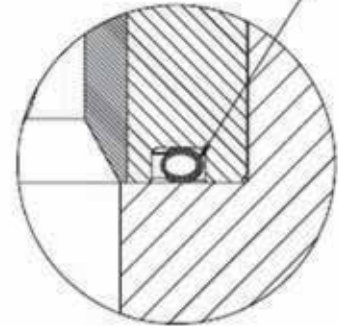
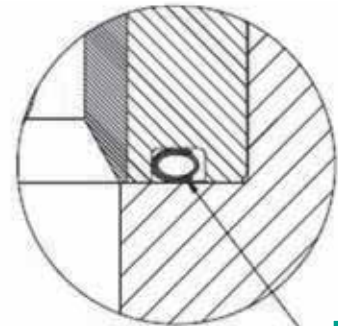

Flow-to-Open Seat-Ring Gasket Detail

21000 Series API 6A Design

Part Tag Codes	Valve Body S/A Part Description	Part Tag Codes	Valve Body S/A Part Description
B001	VALVE BODY	B202	PACKING SPACER
B017	DRIVE NUT	B207	PACKING RING
B102	INTEGRAL SEAT-RING/CAGE	B208	ANTI-EXTRUSION RING
B103	SEAT-RING GASKET	B219	INTEGRAL PACKING FLANGE/FOLLOWER
B105	TRIM RETAINER	B716	O-RING
B149	INTEGRAL PLUG/STEM	B716a	O-RING
B220	PACKING FLANGE STUD	B911	LIFTING LUG
B221	PACKING FLANGE NUT	B921	FLAT WASHER

Material of Construction

Material Class vs Material of Construction

Material Class		Material of Construction Availability			
		Stainless Steel F6NM	Duplex Stainless Steel F51	Duplex Stainless Steel F55	Inconel 718™
AA	General Service	X	X	X	X
BB	General Service	X	X	X	X
CC	General Service	X	X	X	X

Material Class		Material of Construction Availability			
		Stainless Steel F6NM	Duplex Stainless Steel F51	Duplex Stainless Steel F55	Inconel 718™
DD	Sour Service				X
EE	Sour Service				X
FF	Sour Service	X	X	X	X
HH	Sour Service				X

Temperature Rating vs Material of Construction

Temperature Ratings	Temperature Range				Material of Construction Availability			
	Min °C	Max °C	Min °F	Max °F	Stainless Steel F6NM	Duplex Stainless Steel F51	Duplex Stainless Steel F55	Inconel 718™
K	-60	82	-75	180	X			X
L	-46	82	-50	180	X	X	X	X
N	-46	60	-50	140	X	X	X	X
P	-29	82	-20	180	X	X	X	X
S	-18	60	0	140	X	X	X	X
T	-18	82	0	180	X	X	X	X
U	-18	121	0	250	X	X	X	X
V	2	121	35	250	X	X	X	X
X	-18	180	0	350	X	X	X	X

Materials of Construction

Standard Martensitic Stainless-Steel Construction

Max operating pressure: 15 kPSI [1034 bar]

Temperature class: K/L/N/P/S/T/U/V/X⁽¹⁾

Material class: AA/BB/CC/FF⁽¹⁾

Ref. No.	Temperature Range ⁽¹⁾	-76°F (-60°C)	-20°F (-29°C)	250°F (121°C)	356°F (180°C)	
		Materials ⁽¹⁾				
B001	Body	ASTM A182 GR F6NM API6A				
					ASTM A182 GR F6NM API6A Elevated Temperature X	
B017	Drive Nut	SOLUTION ANNEALED 316 STAINLESS STEEL HRC 22 MAXIMUM . HARDNESS COMPLIANCE WITH NACE MR0103 & MR0175 SHALL BE CERTIFIED				
B102	Integral Seat-Ring/ Cage	ASTM A182 GR F6NM CL B + CHROME PLATING + STELLITE N°6 HARDFACING				
B103	Seat-Ring Gasket	INCONEL 718 + SILVER PLATING				
B105	Retainer	SUPER AUSTENITIC STAINLESS STEEL UNS S20910 (NITRONIC 50) 35 HRC MAXIMUM				
B149	Integral Plug/Stem ⁽⁴⁾	ASTM A182 GR F6NM API6A as per CMS-7011 + STELLITE N°6 HARDFACING				
					ASTM A182 GR F6NM API6A Elevated Temperature X + STELLITE N°6 HARDFACING	
B220	Packing Flange Stud ⁽⁵⁾	ASTM A193 GRADE B7 ZINC PLATED ⁽²⁾				
		ASTM A193 GR B7M ELECTROLESS NICKEL PLATING ⁽³⁾				
		ASTM A320 Gr L7 ZINC PLATED ⁽²⁾				
		ASTM A320 Gr L7M ELECTROLESS NICKEL PLATING ⁽³⁾				
B221	Packing Flange Nut ⁽⁵⁾	ASTM A194 GR 7 ZINC PLATED ⁽²⁾				
		ASTM A194 GR 7M ELECTROLESS NICKEL PLATING ⁽³⁾				
		ASTM A 194 GR 2H ZINC PLATED ⁽²⁾				
		ASTM A194 GR 2HM, ELECTROLESS NICKEL PLATING ⁽³⁾				
B202	Packing Spacer	CA6NM CLASS B STAINLESS STEEL HB 255 MAXIMUM				
B207	Packing Ring	LATTYFLON 3265 LM (NO EQUIVALENTS ALLOWED)				
B208	Anti-Extrusion Ring	CARBON-GRAPHITE BRAIDED LATTYGRAF 6995NG (NO EQUIVALENTS ALLOWED)				
B213	Packing Flange/ Follower ⁽⁴⁾	ASTM A182 GR F6NM API6A				
					ASTM A182 GR F6NM API6A Elevated Temperature X	
B716/ B716a	O-ring	VITON-A 65-75 SHORE A				
B921	Flat Washer ⁽⁵⁾	ASTM F436 ZINC PLATED				
		410 ST. ST. HRC 35-45				

Notes:

1. Refer to tables on page 26.
2. For General Service only: Nace Non-Exposed per ANSI/NACE MR0175/ISO 15156-1.
3. For Sour Service only: Nace Exposed per ANSI/NACE MR0175/ISO 15156-1.
4. Considered as pressure containing parts in API 6A specification. See Design Practice BHPD10046.
5. Zinc electroplating is not permitted for splash zone or subsea service.

Materials of Construction

Duplex F51 Stainless-Steel Construction

Max operating pressure: 10 kPSI [690 bar]

Temperature class: L/N/P/S/T/U/V/X⁽¹⁾

Material class: AA/BB/CC/FF⁽¹⁾

Ref. No.	Temperature Range ⁽¹⁾	-51°F (-46°C)	-20°F (-29°C)	250°F (121°C)	356°F (180°C)	
		Description				Materials ⁽¹⁾
B001	Body	ASTM A182 GR F51 API6A				
					ASTM A182 GR F51 API6A Elevated Temperature X	
B017	Drive Nut	SOLUTION ANNEALED 316 STAINLESS STEEL HRC 22 MAXIMUM. HARDNESS COMPLIANCE WITH NACE MR0103 & MR0175 SHALL BE CERTIFIED				
B102	Integral Seat-Ring/ Cage	ASTM A 479 UNS S31803 + STELLITE N°6 + CHROME PLATING				
B103	Seat-Ring Gasket	INCONEL 718 + SILVER PLATING				
B105	Retainer	SUPER AUSTENITIC STAINLESS STEEL UNS S20910 (NITRONIC 50) 35 HRC MAXIMUM				
B149	Integral Plug/Stem ⁽⁴⁾	ASTM A182 GR F51 API6A + STELLITE N°6 HARDFACING				
					ASTM A182 GR F51 API6A Elevated Temperature X + STELLITE N°6 HARDFACING	
B220	Packing Flange Stud ⁽⁵⁾					ASTM A193 GRADE B7 ZINC PLATED ⁽²⁾
						ASTM A193 GR B7M ELECTROLESS NICKEL PLATING ⁽³⁾
						ASTM A320 Gr L7 ZINC PLATED PER CES 1041 ⁽²⁾
						ASTM A320 Gr L7M ELECTROLESS NICKEL PLATING ⁽³⁾
B221	Packing Flange Nut ⁽⁵⁾					ASTM A194 GR 7 ZINC PLATED ⁽²⁾
						ASTM A194 GR 7M ELECTROLESS NICKEL PLATING ⁽³⁾
						ASTM A 194 GR 2H ZINC PLATED ⁽²⁾
						ASTM A194 GR 2HM, ELECTROLESS NICKEL PLATING ⁽³⁾
B202	Packing Spacer	SOLUTION ANNEALED 2205 STAINLESS STEEL (DUPLEX) HRC 28 MAXIMUM				
B207	Packing Ring	LATTYFLON 3265 LM (NO EQUIVALENTS ALLOWED)				
B208	Anti-Extrusion Ring	CARBON-GRAPHITE BRAIDED LATTYGRAF 6995NG (NO EQUIVALENTS ALLOWED)				
B213	Packing Flange/ Follower ⁽⁴⁾	ASTM A182 GR F51 API6A				
					ASTM A182 GR F51 API6A Elevated Temperature X	
B716/ B716a	O-ring	VITON-A 65-75 SHORE A				
B921	Flat Washer ⁽⁵⁾	ASTM F436 ZINC PLATED				
		410 ST. ST. HRC 35-45				
Ref. No.	Temperature Range	-51°F (-46°C)	-20°F (-29°C)	250°F (121°C)	356°F (180°C)	

Notes:

1. Refer to tables on page 26.
2. For General Service only: Nace Non-Exposed per ANSI/NACE MR0175/ISO 15156-1.
3. For Sour Service only: Nace Exposed per ANSI/NACE MR0175/ISO 15156-1.
4. Considered as pressure containing parts in API 6A specification. See Design Practice BHPD10046.
5. Zinc electroplating is not permitted for splash zone or subsea service.

Materials of Construction

Super Duplex F55 Stainless-Steel Construction

Max operating pressure: 15 kPSI [1034 bar]

Temperature class: L/N/P/S/T/U/V/X⁽¹⁾

Material class: AA/BB/CC/FF⁽¹⁾

Ref. No.	Temperature Range ⁽¹⁾	-51°F (-46°C)	-20°F (-29°C)	250°F (121°C)	356°F (180°C)	
		Materials ⁽¹⁾				
B001	Body	ASTM A182 GR F55 API6A				
					ASTM A182 GR F55 API6A Elevated Temperature X	
B017	Drive Nut	SOLUTION ANNEALED 316 STAINLESS STEEL HRC 22 MAXIMUM. HARDNESS COMPLIANCE WITH NACE MR0103 & MR0175 SHALL BE CERTIFIED				
B102	Integral Seat-Ring/ Cage	ASTM A 479 UNS S32760 + STELLITE N°6 + CHROME PLATING				
B103	Seat-Ring Gasket	INCONEL 718 + SILVER PLATING				
B105	Retainer	SUPER AUSTENITIC STAINLESS STEEL UNS S20910 (NITRONIC 50) 35 HRC MAXIMUM				
B149	Integral Plug/Stem ⁽²⁾	ASTM A182 GR F55 API6A as per CMS-7011 + STELLITE N°6 HARDFACING				
					ASTM A182 GR F55 API6A Elevated Temperature X + STELLITE N°6 HARDFACING	
B220	Packing Flange Stud ⁽⁵⁾	ASTM A193 GRADE B7 ZINC PLATED ⁽²⁾				
		ASTM A193 GR B7M ELECTROLESS NICKEL PLATING ⁽³⁾				
		ASTM A320 Gr L7 ZINC PLATED PER CES 1041 ⁽²⁾				
		ASTM A320 Gr L7M ELECTROLESS NICKEL PLATING ⁽³⁾				
B221	Packing Flange Nut ⁽⁵⁾	ASTM A194 GR 7 ZINC PLATED ⁽²⁾				
		ASTM A194 GR 7M ELECTROLESS NICKEL PLATING ⁽³⁾				
		ASTM A 194 GR 2H ZINC PLATED ⁽²⁾				
		ASTM A194 GR 2HM, ELECTROLESS NICKEL PLATING ⁽³⁾				
B202	Packing Spacer	SUPER DUPLEX AUSTENO-FERRITIQUE STAINLESS STEEL (TYPE UNS S32760) HRC 32 MAXIMUM				
B207	Packing Ring	LATTYFLON 3265 LM (NO EQUIVALENTS ALLOWED)				
B208	Anti-Extrusion Ring	CARBON-GRAPHITE BRAIDED LATTYGRAF 6995NG (NO EQUIVALENTS ALLOWED)				
B213	Packing Flange/ Follower ⁽⁴⁾	ASTM A182 GR F55 API6A				
					ASTM A182 GR F55 API6A Elevated Temperature X	
B716/ B716a	O-ring	VITON-A 65-75 SHORE A				
B921	Flat Washer ⁽⁵⁾	ASTM F436 ZINC PLATED				
		410 ST. ST. HRC 35-45				

Notes:

1. Refer to tables on page 26.
2. For General Service only: Nace Non-Exposed per ANSI/NACE MR0175/ISO 15156-1.
3. For Sour Service only: Nace Exposed per ANSI/NACE MR0175/ISO 15156-1.
4. Considered as pressure containing parts in API 6A specification. See Design Practice BHPDI0046.
5. Zinc electroplating is not permitted for splash zone or subsea service.

Materials of Construction

CRA Nickel-Alloy Inconel 718 Construction

Max operating pressure: 15 kPSI [1034 bar]

Temperature class: K/L/N/P/S/T/U/V/X⁽¹⁾

Material class: AA/BB/CC/DD/EE/FF/HH⁽¹⁾

Ref. No.	Temperature Range ⁽¹⁾	-76°F (-60°C)	-20°F (-29°C)	250°F (121°C)	356°F (180°C)	
		Description				Materials ⁽¹⁾
B001	Body	UNS N07718 120K				
					UNS N07718 120K Elevated Temperature X	
B017	Drive Nut	SOLUTION ANNEALED 316 STAINLESS STEEL HRC 22 MAXIMUM HARDNESS COMPLIANCE WITH NACE MR0103 & MR0175 SHALL BE CERTIFIED				
		ASTM B637 GRADE NO7718 (UNS 07718) HRC 40 MAXIMUM HARDNESS COMPLIANCE WITH NACE MR0103 SHALL BE CERTIFIED				
B102	Integral Seat-Ring/ Cage	UNS N07718 120K				
					UNS N07718 120K Elevated Temperature X	
B103	Seat-Ring Gasket	INCONEL 718 + SILVER PLATING				
B105	Retainer	SUPER AUSTENITIC STAINLESS STEEL UNS S20910 (NITRONIC 50) 35 HRC MAXIMUM				
B149	Integral Plug/Stem ⁽⁴⁾	UNS N07718 120K				
					UNS N07718 120K Elevated Temperature X	
B220	Packing Flange Stud ⁽⁵⁾		ASTM A193 GRADE B7 ZINC PLATED ⁽²⁾			
			ASTM A193 GR B7M ELECTROLESS NICKEL PLATING ⁽³⁾			
			ASTM A320 Gr L7 ZINC PLATED PER CES 104 ⁽²⁾			
			ASTM A320 Gr L7M ELECTROLESS NICKEL PLATING ⁽³⁾			
B221	Packing Flange Nut ⁽⁵⁾		ASTM A194 GR 7 ZINC PLATED ⁽²⁾			
			ASTM A194 GR 7M ELECTROLESS NICKEL PLATING ⁽³⁾			
			ASTM A 194 GR 2H ZINC PLATED ⁽²⁾			
			ASTM A194 GR 2HM, ELECTROLESS NICKEL PLATING ⁽³⁾			
B202	Packing Spacer	ASTM B637 GRADE NO7718 (UNS 07718) HRC 40 MAXIMUM HARDNESS COMPLIANCE WITH NACE MR0103 SHALL BE CERTIFIED				
B207	Packing Ring	LATTYFLON 3265 LM (NO EQUIVALENTS ALLOWED)				
B208	Anti-Extrusion Ring	CARBON-GRAPHITE BRAIDED LATTYGRAF 6995NG (NO EQUIVALENTS ALLOWED)				
B213	Packing Flange/ Follower ⁽⁴⁾	UNS N07718 120K				
					UNS N07718 120K Elevated Temperature X	
B716/ B716a	O-ring	VITON-A 65-75 SHORE A (CES-1031)				
B921	Flat Washer ⁽⁵⁾	ASTM F436 ZINC PLATED				
		410 ST. ST. HRC 35-45				
Ref. No.	Temperature Range	-76°F (-60°C)	-20°F (-29°C)	250°F (121°C)	356°F (180°C)	

Notes:

1. Refer to tables on page 26.

2. For General Service only: Nace Non-Exposed per ANSI/NACE MR0175/ISO 15156-1.

3. For Sour Service only: Nace Exposed per ANSI/NACE MR0175/ISO 15156-1.

4. Considered as pressure containing parts in API 6A specification. See Design Practice BHDP10046.

5. Zinc electroplating is not permitted for splash zone or subsea service.

Materials of Construction

Common Parts

Temperature class: K/L/N/P/S/T/U/V/X⁽¹⁾

Material class: AA/BB/CC/DD/EE/FF/HH⁽¹⁾

Ref. No.	Temperature Range ⁽¹⁾	-76°F (-60°C)	356°F (180°C)
	Description	Materials ⁽¹⁾	
B703	Serial Plate	GENERAL SERVICE ANNEALED 316L ST. ST. HRc 22 MAX	
B704	Flow Arrow	AUSTENITIC STAINLESS STEEL	
B902	Drive Screw	AUSTENITIC STAINLESS STEEL	
B911	Lifting Lugs	STAINLESS STEEL	

Notes:

1. Refer to tables on page 26.

Dimensions

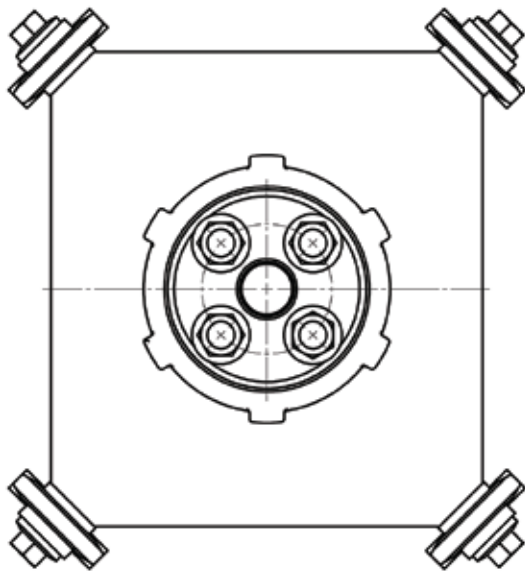
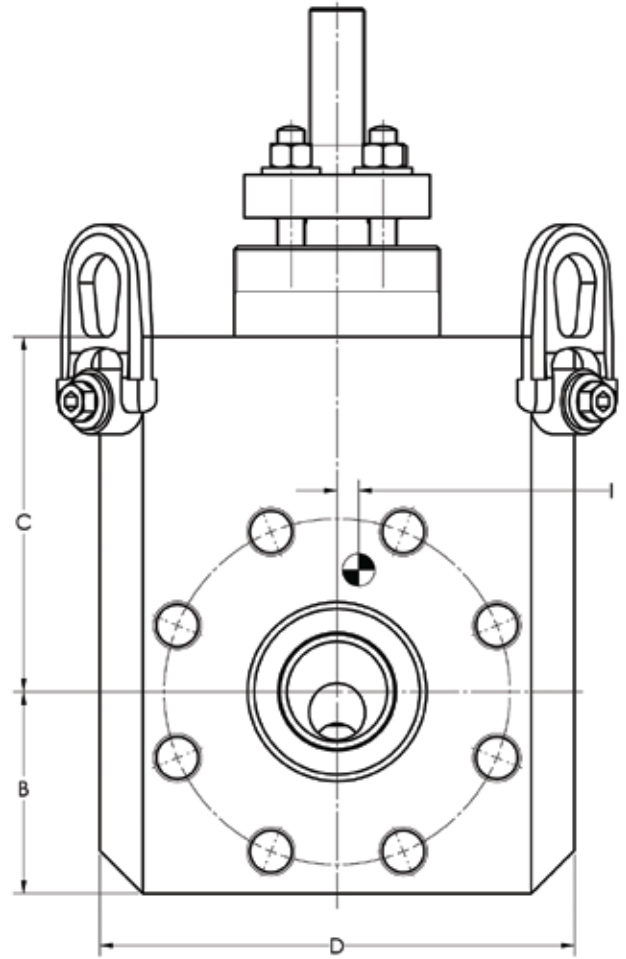
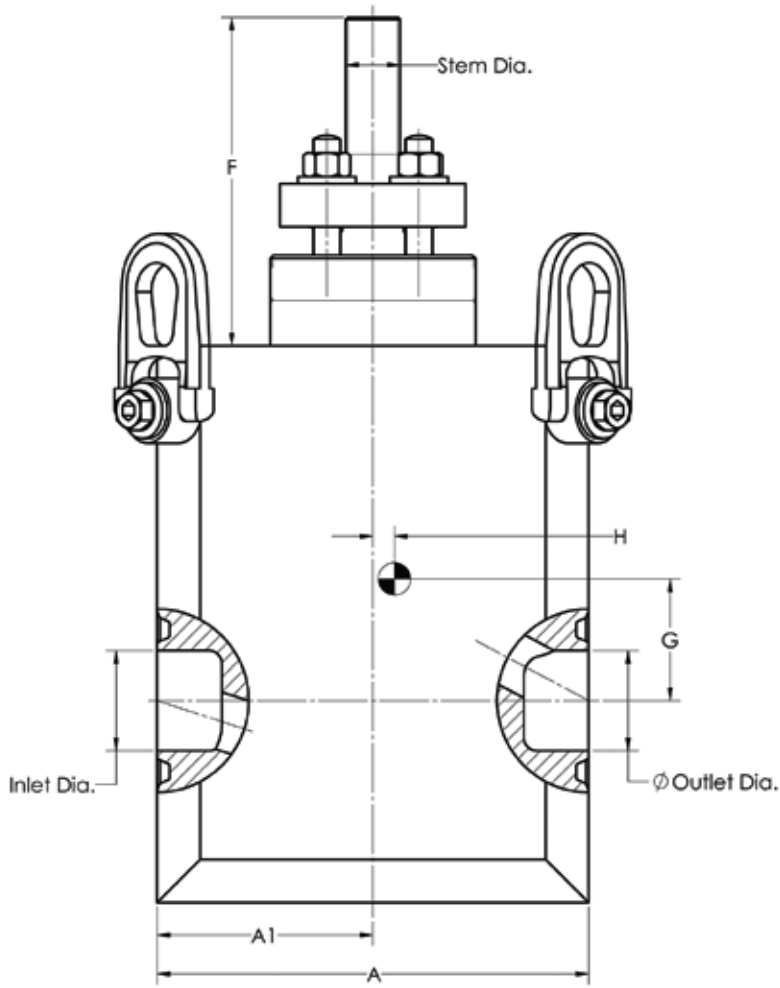

Weights and Dimensions

API 10K & 15K Body S/A (mm)

Valve Trim Size (in)	Valve Ends Size (NPS)	Max Operating Pressure (PSI)	Valve Ends	Stem Diameter	Inlet Diameter	Outlet Dia.	Spud Diameter	A	A1	B	C	D	G	H	I	Approx. Mass (kg)
0.75	1 ¹ / ₃ /16	10K	6BX	3/4" 16UNF-3A	46.45	46.45	3 ⁵ / ₁₆ 16UNS-2A	160	80	93.5	131.5	220	29.5	0	0	61
0.75	1 ¹ / ₃ /16	15K	6BX	3/4" 16UNF-3A	46.45	46.45	3 ⁵ / ₁₆ 16UNS-2A	160	80	93.5	131.5	220	29.5	0	0	61
1	1 ¹ / ₃ /16	10K	6BX	1" 14UNF-3A	46.45	46.45	3 ³ / ₄ 12UNS-2A	200	100	93.6	164.4	220	46	0	0	88
1	1 ¹ / ₃ /16	15K	6BX	1" 14UNF-3A	46.45	46.45	3 ³ / ₄ 12UNS-2A	200	100	93.6	164.4	220	46	0	0	88

API 10K & 15K Body S/A (in.)

Valve Trim Size (in)	Valve Ends Size (NPS)	Max Operating Pressure (PSI)	Valve Ends	Stem Diameter	Inlet Diameter	Outlet Dia.	Spud Diameter	A	A1	B	C	D	G	H	I	Approx. Mass (lb)
0.75	1 ¹ / ₃ /16	10K	6BX	3/4" 16UNF-3A	1.829	1.829	3 ⁵ / ₁₆ 16UNS-2A	6.299	3.150	3.681	5.175	8.661	1.161	0	0	134
0.75	1 ¹ / ₃ /16	15K	6BX	3/4" 16UNF-3A	1.829	1.829	3 ⁵ / ₁₆ 16UNS-2A	6.299	3.150	3.681	5.175	8.661	1.161	0	0	134
1	1 ¹ / ₃ /16	10K	6BX	1" 14UNF-3A	1.829	1.829	3 ³ / ₄ 12UNS-2A	7.874	3.937	3.681	6.472	8.661	1.811	0	0	194
1	1 ¹ / ₃ /16	15K	6BX	1" 14UNF-3A	1.829	1.829	3 ³ / ₄ 12UNS-2A	7.874	3.937	3.681	6.472	8.661	1.811	0	0	194

Dimensions (inches)

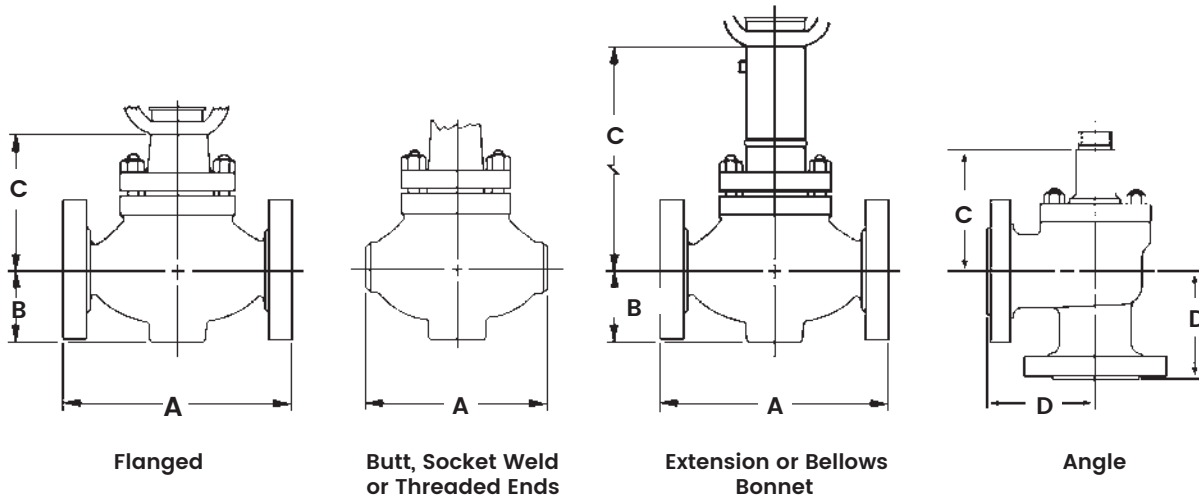

21000 Series Dimensions (inches)

Valve Size (inches)	A													
	ASME Class 150-600 (PN 20-100)	ASME Class 900-1500 (PN 150-250)	ASME Class 2500 (PN 420)	ASME Class 150 (PN 20)	ASME Class 300 (PN 50)		ASME Class 600 (PN 100)		ASME Class 900 (PN 150)		ASME Class 1500 (PN 250)		ASME Class 2500 (PN 420)	
	BW, SW, THD	BW, SW, THD	BW, SW, THD	RF	RF	RTJ	RF	RTJ	RF	RTJ	RF	RTJ	RF	RTJ
0.75	8.25	8.50	12.50	7.25	7.63	8.11	8.11	8.11	10.75	10.75	10.75	10.75	12.12	12.12
1	8.25	8.50	12.50	7.25	7.75	8.25	8.25	8.25	11.50	11.50	11.50	11.50	12.50	12.50
1.5	9.88	9.25	13	8.75	9.25	9.76	9.88	9.88	13.12	13.12	13.12	13.12	14.12	14.25
2	11.25	11.50	14.75	10	10.50	11.12	11.25	11.38	14.75	14.88	14.75	14.88	16.25	16.37
3	13.24	12.50		11.75	12.50	13.12	13.25	13.38	15.24	15.31	15.99	16.06		
4	15.50	14.49		13.88	14.50	15.12	15.50	15.62	18.27	18.34	19.02	19.09		
6	20			17.75	18.62	19.25	20	20.12						
8	24			21.38	22.36	22.83	24	24.09						

Valve Size (inches)	B													
	ANSI Class 150-300 (PN 20-50)	ANSI Class 600 (PN 100)	ANSI Class 150-600 (PN 20-100)	ANSI Class 900-1500 (PN 150-250)		ANSI Class 2500 (PN 420)		ANSI Class 150 (PN 20)	ANSI Class 300 (PN 50)	ANSI Class 600 (PN 100)	ANSI Class 900 (PN 150)	ANSI Class 1500 (PN 250)	ANSI Class 2500 (PN 420)	
	BW	BW	SW & THD	BW	SW	BW	SW	RF	RF & RTJ	RF & RTJ	RF & RTJ	RF & RTJ	RF & RTJ	
0.75			1.83		2.15		2.42	2	2.29	2.29	2.59	2.59	2.79	
1			1.83		2.15		2.42	2.19	2.49	2.49	2.98	2.98	3.18	
1.5			2.50		2.81		3.17	2.50	3.08	3.08	3.57	3.57	4.06	
2	3	3	3	3.53	3.53	3.87	3.87	3	3.28	3.30	4.26	4.26	4.66	
3	3.69	3.69		4.36				3.77	4.16	4.16	4.72	5.22		
4	5	5.50		5.75				4.98	5.05	5.50	5.75	6.10		
6	6.26	7.37						6.26	6.36	7.37				
8	7.68	7.68						7.68	7.68	8.27				

Dimensions (mm)

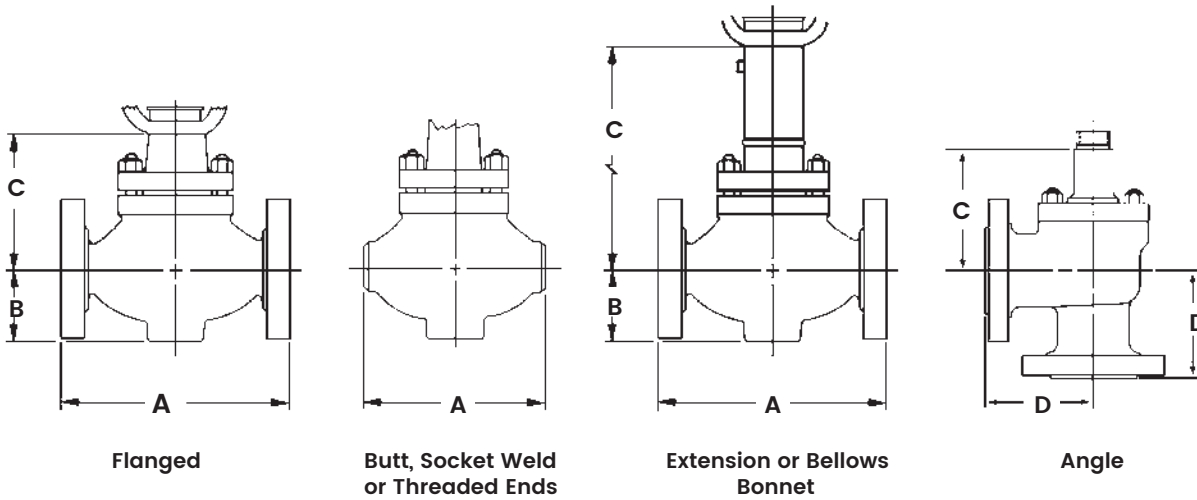

21000 Series Dimensions (mm)

Valve Size (mm)	A													
	ASME Class 150-600 (PN 20-100)	ASME Class 900-1500 (PN 150-250)	ASME Class 2500 (PN 420)	ASME Class 150 (PN 20)	ASME Class 300 (PN 50)		ASME Class 600 (PN 100)		ASME Class 900 (PN 150)		ASME Class 1500 (PN 250)		ASME Class 2500 (PN 420)	
	BW, SW, THD	BW, SW, THD	BW, SW, THD	RF	RF	RTJ	RF	RTJ	RF	RTJ	RF	RTJ	RF	RTJ
20	210	216	318	184	194	206	206	206	273	273	273	273	308	308
25	210	216	318	184	197	210	210	210	292	292	292	292	318	318
40	251	235	330	222	235	248	251	251	333	333	333	333	359	362
50	286	292	375	254	267	283	286	289	375	378	375	378	413	416
80	336	318		299	318	333	337	340	387	389	406	408		
100	394	368		353	368	384	394	397	464	466	483	485		
150	508			451	473	489	508	511						
200	610			543	568	580	610	612						

Valve Size (mm)	B												
	ANSI Class 150-300 (PN 20-50)	ANSI Class 600 (PN 100)	ANSI Class 150-600 (PN 20-100)	ANSI Class 900-1500 (PN 150-250)		ANSI Class 2500 (PN 420)		ANSI Class 150 (PN 20)	ANSI Class 300 (PN 50)	ANSI Class 600 (PN 100)	ANSI Class 900 (PN 150)	ANSI Class 1500 (PN 250)	ANSI Class 2500 (PN 420)
	BW	BW	SW & THD	BW	SW	BW	SW	RF	RF & RTJ	RF & RTJ	RF & RTJ	RF & RTJ	RF & RTJ
20			47		55		62	51	58	58	66	66	71
25			47		55		62	56	63	63	76	76	81
40			64		72		81	64	78	78	91	91	103
50	76	76	76	90	90	96	98	76	83	84	108	108	118
80	95	95		111				96	106	106	120	133	
100	127	140		146				127	128	140	146	155	
150	159	187						159	162	187			
200	195	195						195	195	210			

Weights

Body S/A with Standard Bonnet (lbs)

Valve Size (inches)	ASME Class 150 – 300 (PN 20 – 50)		ASME Class 600 (PN100)		ASME Class 900 – 1500 (PN 150 – 250)		ASME Class 2500 (PN 420)	
	FLG	BW, SW & THD	FLG	BW, SW & THD	FLG	BW, SW & THD	FLG	BW, SW & THD
0.75	36	27	38	27	57	44	70	44
1	36	27	38	27	75	44	90	44
1.5	49	36	53	36	100	57	118	57
2	57	44	64	44	144	82	255	154
3	127	73	128	99	199	146		
4	196	121	216	135	409	318		
6	355	238	450	272				
8	682	610	771	610				

Body S/A with Standard Bonnet (kg)

Valve Size (mm)	ASME Class 150 – 300 (PN 20 – 50)		ASME Class 600 (PN100)		ASME Class 900 – 1500 (PN 150 – 250)		ASME Class 2500 (PN 420)	
	FLG	BW, SW & THD	FLG	BW, SW & THD	FLG	BW, SW & THD	FLG	BW, SW & THD
20	16	12	17	12	26	20	32	20
25	16	12	17	12	34	20	41	20
40	22	16	24	16	45	26	53	26
50	26	20	29	20	65	37	116	70
80	58	33	58	45	90	66		
100	89	55	98	61	186	144		
150	161	108	204	123				
200	309	277	350	277				

87/88 Dimensions and Weights (in./lbs)

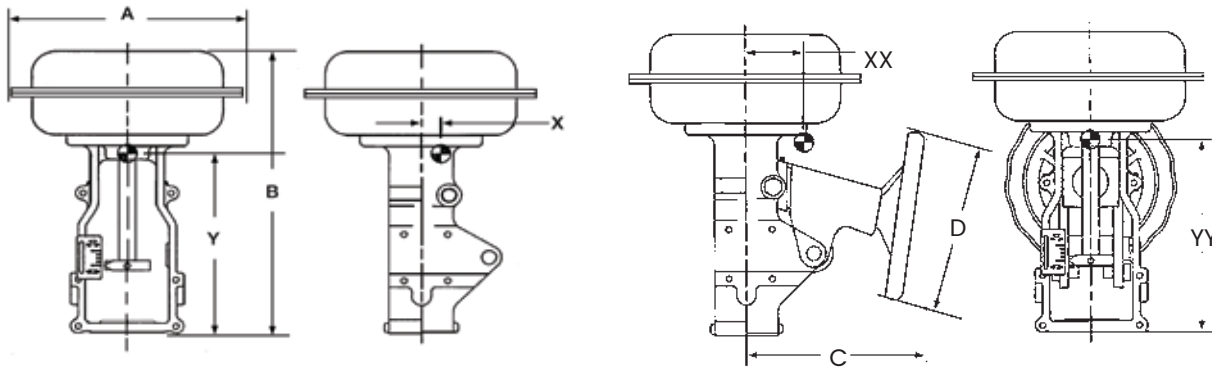

Shown with optional Handwheel

Dimensions and Weights

Actuator Size	Actuator Dimensions (inches)				Weights (lbs.)	
	A	B (Model 88)	C	D	Standard	w/Handwheel
6	11.50	15.54 (17.52)	10.00	9.00	45	60
10	14.50	19.58 (21.54)	10.90	12.00	85	105
16	18.75	28.22 (30.79)	14.00	18.00	210	245
23	23.63	30.71 (33.27)	16.00	18.00	265	320

Actuator Removal Clearance = 6 inches

Center of Gravity (inches)

Without Handwheel

Size	X	Y
6	.19	9.75
10	.0	12.88
16	.13	18.50
23	.06	21.13

With Handwheel

Size	XX	YY
6	1.25	9.13
10	0.88	12.00
16	1.38	16.75
23	1.38	19.00

Limit Stops (inches)

Up Stop

Size	Model	Overall Height B
6	87	19.45
10		25.43
16		36.42
23		38.84
6	88	19.16
10		25.06
16		35.48
23		28.65

Down Stop

Size	Model	Overall Height B
6	87	19.80
10		25.98
16		37.20
23		39.90
6	88	19.74
10		25.85
16		37.46
23		40.33

87/88 Dimensions and Weights (mm/kg)

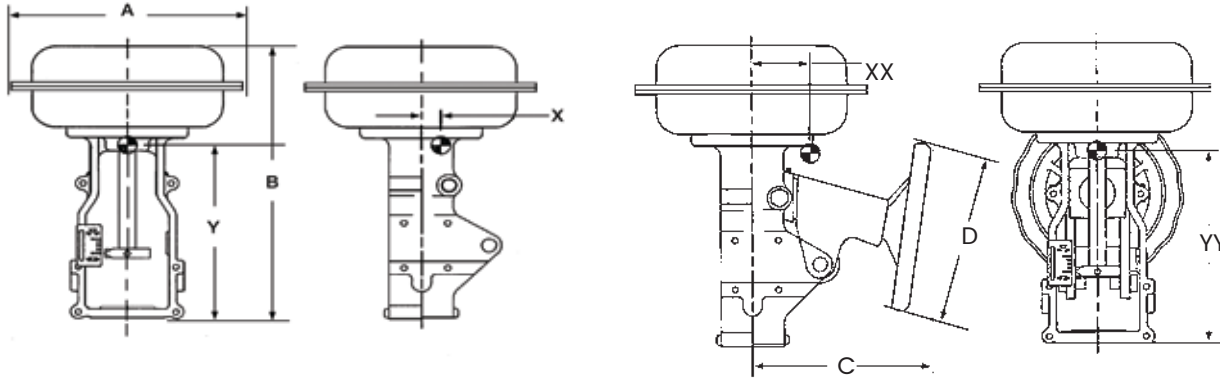

Shown with optional Handwheel

Dimensions and Weights

Actuator Size	Actuator Dimensions (mm)				Weights (kg)	
	A	B (Model 88)	C	D	Standard	w/Handwheel
6	302	395 (445)	254	229	20	27
10	373	497 (547)	277	305	39	48
16	476	717 (782)	356	457	95	111
23	600	780 (845)	406	457	120	145

Actuator Removal Clearance = 152mm

Center of Gravity (mm)

Without Handwheel

Size	X	Y
6	5	248
10	0	327
16	3	470
23	2	537

With Handwheel

Size	XX	YY
6	32	232
10	22	305
16	35	425
23	35	483

Limit Stops (mm)

Up Stop

Size	Model	Overall Height B
6	87	494
10		646
16		925
23		987
6	88	487
10		636
16		901
23		982

Down Stop

Size	Model	Overall Height B
6	87	503
10		660
16		945
23		1014
6	88	501
10		657
16		952
23		1024



CONTROLS SUPPLY CHAIN

VALVES ACTUATORS INSTRUMENTATIONS