

Masoneilan™ 33000 Series

Triple Offset
Butterfly Valves



Table of Contents

Overview / Features & Benefits	3.....
Numbering System	4.....
General Data - Actuator Mounting Positions.....	5-6
Body Assembly Data	7.....

Materials of Construction

Standard	8.....
Standard CL 600.....	9.....
Exploded View Standard	10....
Exploded View 3" and 4" CL 600	11....
Cryogenic	12-13
Exploded View Cryogenic.....	14....

Rated Flow Coefficients

Flow to Close - ASME 150.....	15....
Flow to Open - ASME 150.....	16....
Flow to Close - ASME 300.....	17....
Flow to Open - ASME 300.....	18....
Flow to Close - ASME 600.....	19....
Flow to Open - ASME 600.....	20....

Weights and Dimensions.....	21....
------------------------------------	---------------

Actuator Data

Model 33.....	22.....
Model 31/32.....	23.....
Models 33 & 31/32 Dimensions.....	24....
CP/GP Series.....	25....
CP Series Dimensional Drawing.....	26....
CP Series Dimensions.....	27....
CP Series Dimensional Drawing with Manual Operator	28
CP Series Dimensions With Manual Operator	29-30
GP Series Dimensional Drawing	31....
GP Series Dimensions.....	32-35

Overview

Masoneilan's 33000 Series Triple Offset Butterfly Valve incorporates new performance enhancing operational features, allowing for a more simplified manufacturing process. The result is exclusive patented range of superior performance zero leakage bi-directional triple offset butterfly valves, suitable for extreme pressure/temperature applications.

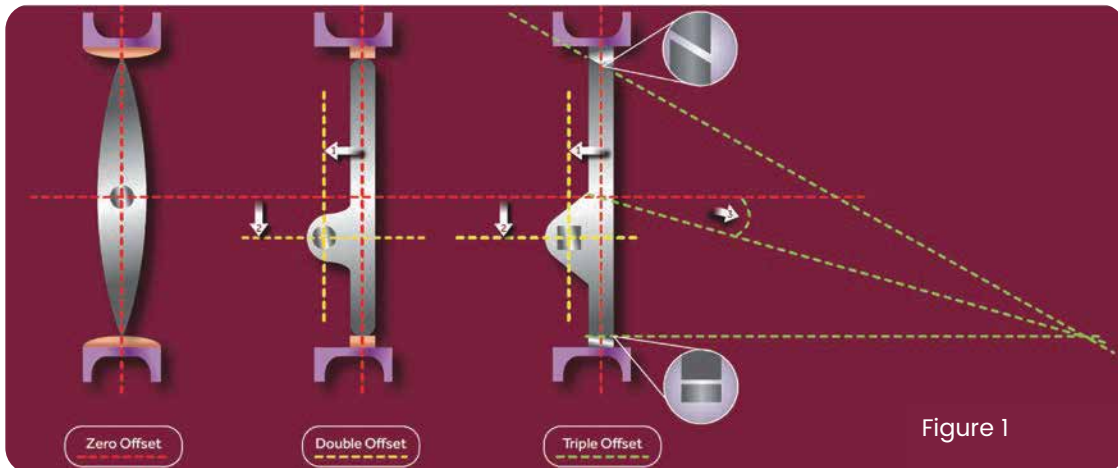

Features & Benefits

The 33000 Series Triple Offset Butterfly Valve incorporates new performance enhancing operational features including:



Conical Sealing

A design focused on circular conical sealing technology means a better seal with max C_v , that performs at 100% for longer performance. Many other designs use elliptical seals, which create greater drag, reducing C_v and increasing wear.



Zero Leakage

Our patented seat and seal technology makes for a more reliable valve. Better by design, there is only one theoretical leak path; properly maintained and operated, a Masoneilan 33000 Series valve means leak-free operation.

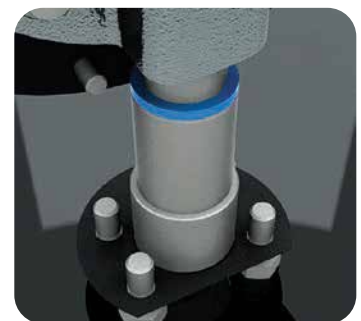

Less Downtime

When the time comes to carry out essential maintenance, the Masoneilan 33000 Series design pays massive dividends. Components can be quickly inspected, removed and replaced, saving you valuable plant downtime.

Numbering System

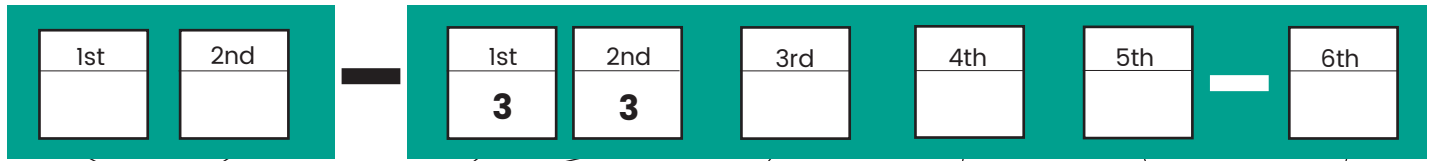

Actuator Type and Action on Air Failure	Body Series	Actuator Mounting Position (see Figure 2 on page 5)	Construction Option	Design Series	Options
31 Spring opposed rolling diaphragm (Air To Close) ¹ 32 Spring opposed rolling diaphragm (Air To Open) ¹ 33 Spring Diaphragm (Air To Extend action only) ¹ CP Scotch-Yoke Piston Cylinder GP Scotch-Yoke Piston Cylinder A/AB/IW- Manual Operator	33 Triple Offset Butterfly Valve	0 Not used 1 Horizontal above center valve closes on stem extension (Air To Close) 2 Horizontal above center valve opens on stem extension (Air To Open) 3 Vertical above center valve closes on stem extension (Air To Close) 4 Vertical above center valve opens on stem extension (Air To Open) ² 5 Horizontal below center valve opens on stem extension (Air To Close) 6 Horizontal below center valve opens on stem extension (Air To Open) 7 Vertical below center valve closes on stem extension (Air To Close) 8 Vertical below center valve opens on stem extension (Air To Open)	0 Not Defined 1 Lugged (Drilled Through) 2 Lugged (Threaded) 3 Double Flanged (Short Pattern) 4 Wafer 5 Double Flanged (Long Pattern) ³	0	C Cryogenic ³ FS Fire Safe

Notes:

1. Up to 8" only
2. Standard configuration
3. Dimensional information available upon request

General Data – Actuator Mounting Positions

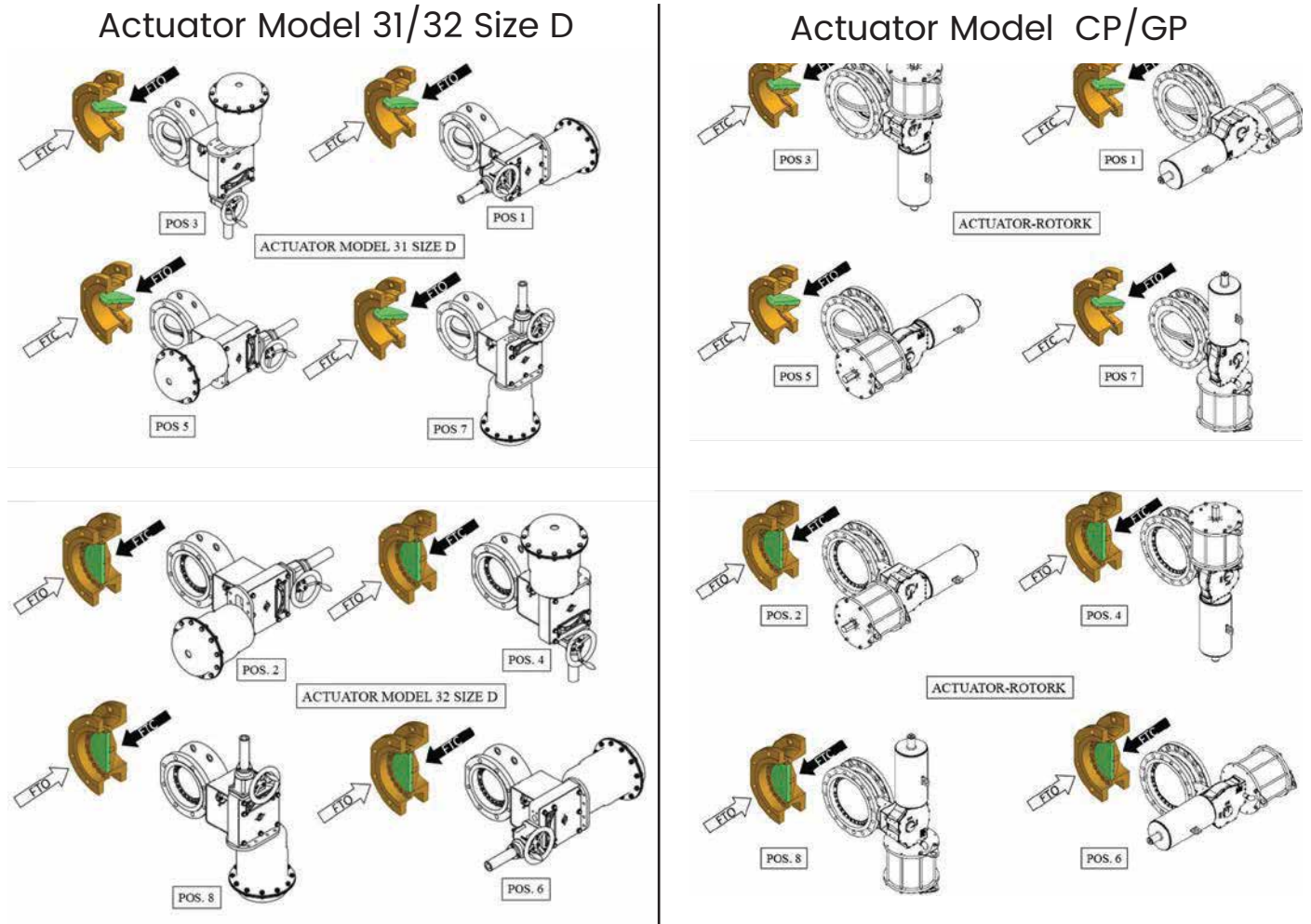

Figure 2 - Actuator Mounting Positions

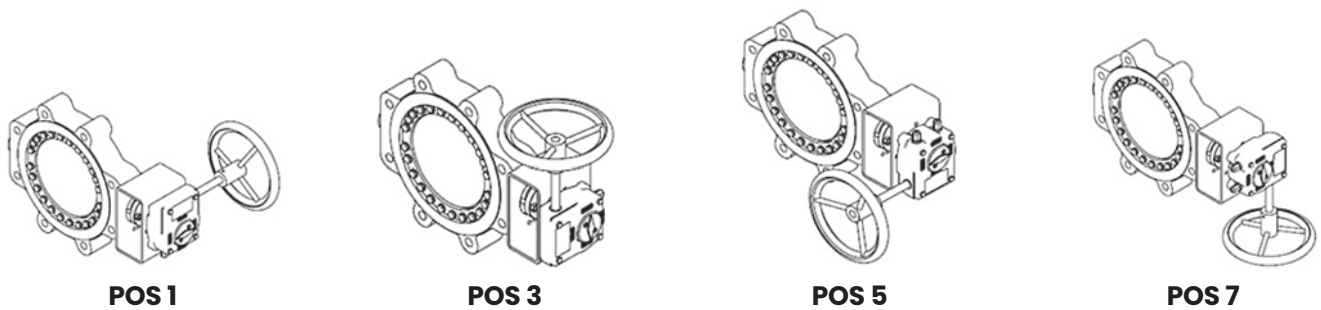

Figure 3 - Manual Operator Gearbox

General Data

Flow Direction:	bi-directional (Preferred Direction: Shaft Upstream i.e. Flow To Close Reverse direction optional i.e. shaft downstream or Flow To Open)
Seat ring Seal Type:	laminated material
Seat Leakage:	Class IV (Standard) per IEC 60534-4 &ANSI/FCI 70-2 Class VI (Optional) per IEC 60534-4 &ANSI/FCI 70-2 Class V (Preferred direction only) API 598 (preferred direction only)
Cv Ratio:	50:1
Inherent Flow Characteristic:	Equal Percentage

End Connections



Figure 3
Wafer



Figure 4
Lugged



Figure 5
Double Flanged

Certificates / Design Codes

Certifications

The 33000 valves comply with:

- ASME B16-34
- European directives PED 2014/68/EU and ATEX 2014/34/EU
- Canada Registration Number (CRN)
- CU-TR 032 & CU-TR 012 Category 1, 2 & 3
- Fire Safe according to NF EN ISO 10497 & API 607
- API 598
- ISO 15848 Fugitive Emissions
- IBR
- AQSIQ
- SIL 3 according to IEC 61508

Body Assembly Data

Cast integral bonnet, Short neck design

Body Style Options:

- Lugged (Through Holes & Drilled & Threaded Holes)
- Wafer
- Double Flanged Short Pattern (DFSP)
- Double Flanged Long Pattern (DFLP)

Body Face To Face:

- Wafer and lugged bodies API 609 Table-3 (A) (Category B Valves for sizes up to 48")
- Double flanged long pattern: API609 table 3 (B) (Category B Valves for sizes up to 48")
- Double flanged short pattern: API609 table 3 (C) (Category B Valves for sizes up to 48")
 - o Class 150: dimensions agree with ISO 5752 Basic series 13 and EN 558-2 and EN 593
 - o Class 300: dimensions agree with ISO 5752 Basic series 14 and EN 558-2 and EN 593
 - o Class 600: dimensions agree with ISO 5752 Basic series 14 and EN 558-2 and EN 593

Body End Options:

- Raised Face on Lugged and wafer
- Raised Face Flange
- Flange finishing: Ra 3.2µm - 6.4µm (125-250 AARH)
 - Other flange facings and surface finishes available on request
- Ring Type Joint optional
- Butt weld end optional

Body Materials:

- Carbon steel WCC
- Stainless steel CF8M
- Low Temperature Carbon Steel LCC
- Duplex and Chrome Moly
- Other material available upon request

Special Applications:

Designed with metal-to-metal seats, and optional extended bonnet design, the 33000 Series is ideal to maintaining zero leakage performance under harsh conditions, including LNG cryogenic conditions (-196°C), and fire resistant environments requiring API 607 and ISO EN 10497 certification.



Standard Materials of Construction

(Refer to parts list on page 10)

Valve Sizes: 3" to 48"

Body Ratings: ANSI Class 150 to 300

Temperature Range (in °F)		-50°F	-20°F	650°F
Part No.	Description	Standard Materials		
B001	Body	A216 GR WCC/WCB/EN 1.0619/1.0625		
		ASTM A352 GR LCC		
		ASTM A351 Grade CF8M/EN 1.4408		
B011	Bearing	ASTM A479 UNS S31603 Hard Coated		
B208	Bearing Protector	Die Formed Graphite		
B102	Seat Ring (CL 150)	ASTM A240 UNS S31600 with Laminated Graphite Sheet for Valve Size ≤10"		
		ASTM B443 UNS N06625 with Laminated Graphite Sheet for Valve Size ≥12"		
	Seat Ring (CL 300)	ASTM A240 UNS S31600 with Laminated Graphite Sheet for Valve Size ≤8"		
		ASTM B443 UNS N06625 with Laminated Graphite Sheet for Valve Sizes ≥10"		
B913c	Seat Ring Fasteners (CL 150)	A4-80 (ISO 3506) 316L		
	Seat Ring Fasteners (CL 300)	ASTM A564 UNS S17400 H1150D		
B103	Seat Ring Gasket	NR40 Nickel Reinforced Graphite Sheet		
B206	Packing Set	Gland Packing Passivated / Braided Graphite Packing		
B105	Seat Ring Retainer	Solution Annealed 316L Stainless Steel		
B137	Disc Retainer	Solution Annealed 316 Stainless Steel		
B913	Disc Fasteners	A4-80 (ISO 3506) 316L		
B138	Disc	Solution Annealed 316L Stainless Steel		
B010	End Plate	Solution Annealed 316L Stainless Steel		
B913a	End Plate Fasteners	ASTM A564 UNS S17400 H1150D		
B015	End Plate Gasket	NR40 Nickel Reinforced Graphite		
B213	Packing Flange	Solution Annealed 316L Stainless Steel		
B201	Packing Nut	A4-80 (ISO 3506) 316L		
B202	Packing Ring	ASTM A479 UNS S31603 Hard Coated		
B200	Packing Stud	A4-80 (ISO 3506) 316L		
B123	Shaft	ASTM A564 UNS S17400 H1150D		
B139	Thrust Pad	ASTM A479 UNS S31603 Hard Coated		
B913b	Thrust Pad Fastener	A4-80 (ISO 3506) 316L		
B903	Dowel Pin	17-4PH Type 630(H1150D)		
Part No.	Temperature Range (in °C)	-46°C	-29°C	343°C

Standard Materials of Construction CL 600

(Refer to parts list on page 10)

Valve Sizes: 3" to 20"

Body Ratings: ANSI Class 600

Temperature Range (in °F)		-50°F	-20°F	650°F
Part No.	Description	Standard Materials		
B001	Body			A216 GR WCC/WCB/EN 1.0619/1.0625 CMS-1040
				ASTM A217 Grade WC9 HRc 22 Maximum and CMS-1040
				ASTM A352 GR LCC HRc 22 Maximum CMS-1040
				ASTM A351 Grade CF8M/EN 1.4408 CMS-1040 HRc 22 Maximum
B011	Bearing			ASTM A479 UNS S31603 Titanium Nitride Coated
B208	Bearing Protector			Die Formed Graphite
B102	Seat Ring			ASTM B443 UNS N06625 with Laminated Graphite Sheet
B913b ¹	Seat Ring Fasteners			17-4PH Type 630 (H1150D)
B915a ²				
B103	Seat Ring Gasket			SST100 - Tanged Stainless Steel reinforced Graphite Sheet
B206	Packing Set			Gland Packing Passivated / Gland Packing Braided
B105	Seat Ring Retainer			Solution Annealed 316L Stainless Steel HRc 22 Maximum
B137	Disc ³			Solution Annealed 316 Stainless Steel HRc 22 Maximum
B913	Disc Fasteners ³			A4-80 (ISO 3506) 316L
B138	Integrated Disc and Disc Seat ⁴			17-4PH Type 630 (H1150D)
B929	Key ⁴			17-4PH Type 360 (H1150D)
B914	Grub Screw ⁴			ASTM B446 HRc 35 Maximum (UNS N06625) Hot Worked and Annealed
B138	Disc Seat ³			Solution Annealed 316 Stainless Steel HRc 22 Maximum
B010	End Plate			ASTM A351 GR CF3M/EN 14408 C:0.03/14409 CMS-1040 HRc 22 Maximum
B913a	End Plate Fasteners			ASTM A564 UNS S17400 H1150D
B015	End Plate Gasket			SST100 - Tanged Stainless Steel Reinforced Graphite Sheet
B213	Packing Flange			Solution Annealed 316L Stainless Steel HRc 22 Maximum
B201	Packing Nut			A4-80 (ISO 3506) 316L
B202	Packing Ring			ASTM A479 UNS S31603 Titanium Nitride Coated
B200	Packing Stud			A4-80 (ISO 3506) 316L
B123	Shaft			17-4PH Type 630 (H1150D)
B139	Thrust Pad			ASTM A479 UNS S31603 Titanium Nitride Coated
B915	Thrust Pad Fastener			A4-80 (ISO 3506) 316L
B903	Dowel Pin			17-4PH Type 630 (H1150D)
Part No.	Temperature Range (in °C)	-46°C	-29°C	343°C

Notes:

1. Used from 3" to 8" CL 600
2. Used from 10" to 20" CL 600
3. Not Available in 3" and 4" CL 600
4. Available in 3" and 4" CL 600 only

Exploded View Standard

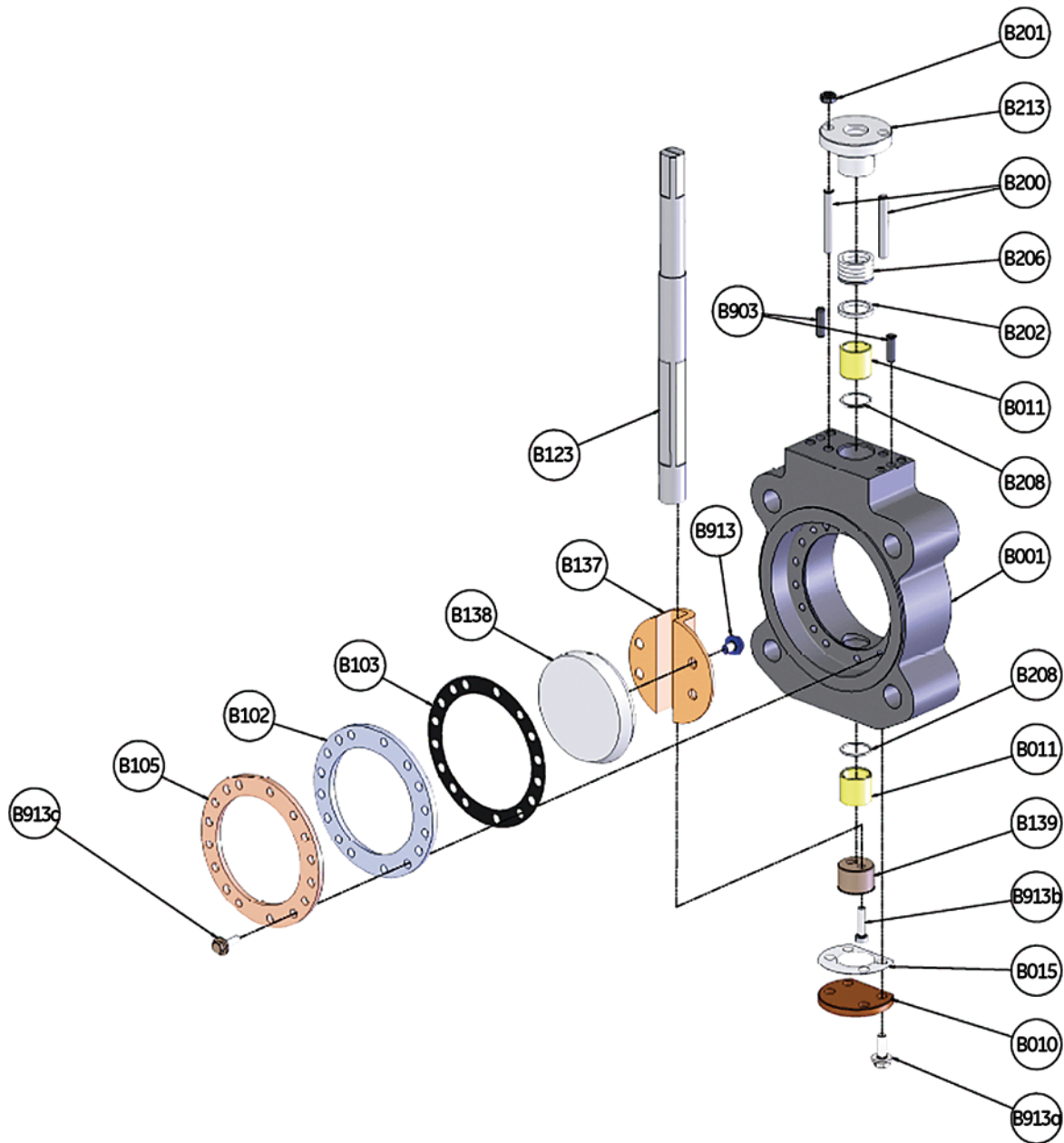

Part No.	Description
B001	Body
B010	End Plate
B011	Bearing
B015	End Plate Gasket
B102	Seat Ring
B103	Seat Ring Gasket
B105	Seat Ring Retainer
B123	Shaft
B137	Disc Retainer
B138	Disc
B139	Thrust Pad

Part No.	Description
B200	Full Threaded Stud
B201	Hex Nut
B202	Gland Packing Ring
B206	Gland Packing
B208	Bearing Protector
B213	Gland
B903	Dowel Pin
B913	Flange Hex Bolt
B813a	Flange Hex Bolt
B913b	Cap Head Screw
B913c	Flange Hex Bolt

Exploded View Standard Class 600 (3" & 4" Only)

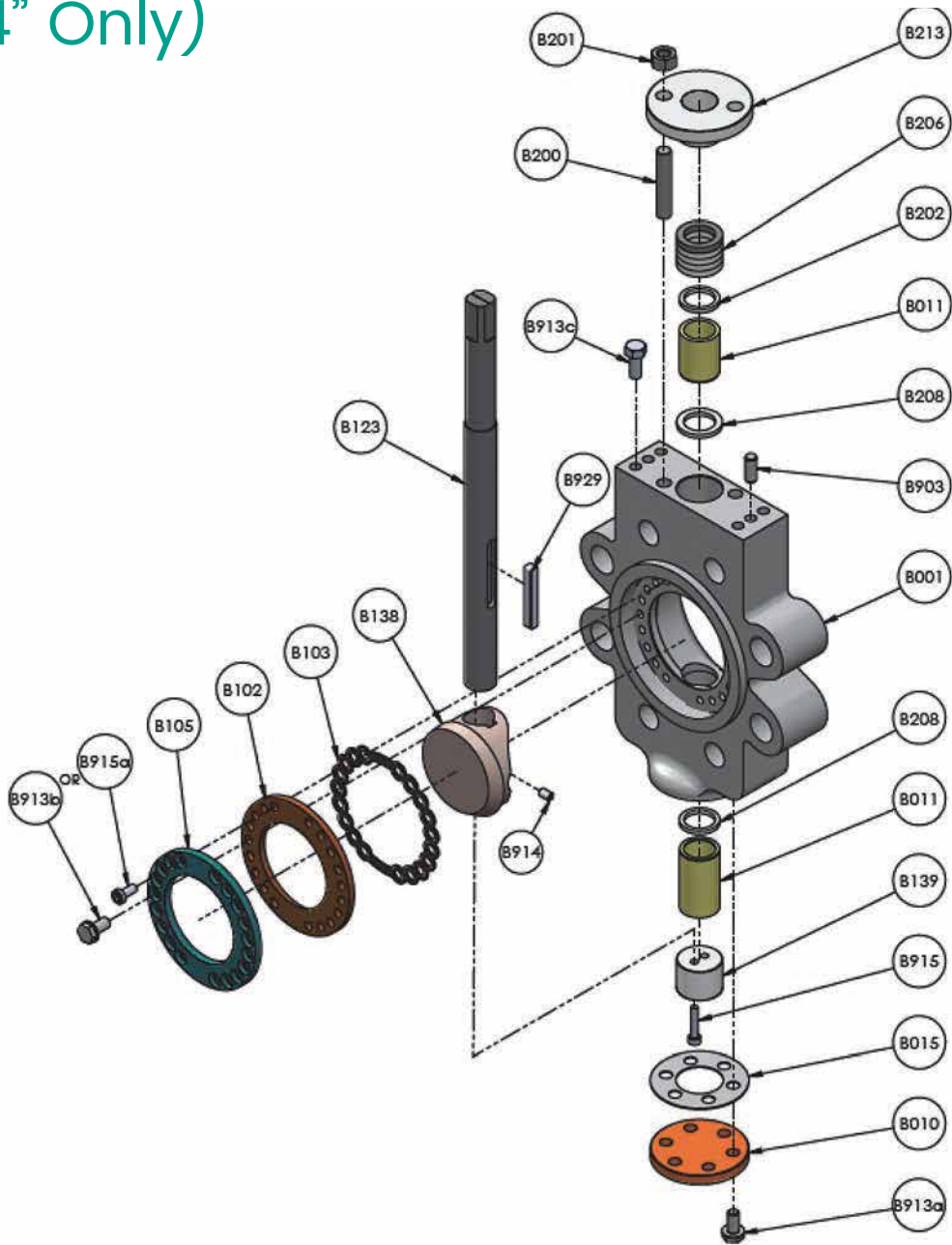

Part No.	Description
B001	Body
B010	End Plate
B011	Bearing
B015	End Plate Gasket
B102	Seat Ring
B103	Seat Ring Gasket
B105	Seat Ring Retainer
B123	Shaft
B138	Disc Seat
B139	Thrust Pad
B200	Full Threaded Stud
B201	Hex Nut

Part No.	Description
B202	Gland Packing Ring
B206	Gland Packing
B208	Bearing Protector
B213	Gland
B903	Dowel Pin
B813a	Flange Hex Bolt
B913b	Flange Hex Bolt
B913c	Flange Hex Bolt
B914	Set Screw
B915	Cap Head Screw
B915a	Cap Head Screw
B929	Shaft Key

Cryogenic Materials of Construction

(Refer to parts list on page 14)

Valve Sizes: 3" to 24"

Body Ratings: ANSI Class 150 to 300

Temperature Range (in °F)		-320°F	-50°F	-20°F
Part No.	Description	Standard Materials		
B001	Body	ASTM A351 Grade CF8M/EN 1.4408 CMS-1040 HRc 22 Maximum		
B003	Cryogenic Extension	ASTM A351 Grade CF8M/EN 1.4408 CMS-1040 HRc 22 Maximum		
B015a	Body Gasket	316L Stainless Steel Spiral w/Gasket and Graphite Filler		
B002	Body Stud	ASTM A193 Grade B8 Class 2		
B014	Body Stud Nut	ASTM A194 Grade 8 HRc 22 Maximum		
B011	Bearing	ASTM A479 UNS S31603 Titanium Nitride Coated		
B011a	Sleeve	Solution Annealed 316L Stainless Steel HRc 22 Maximum		
B208	Bearing Protector	Die Formed Graphite		
B102	Seat Ring (CL150) ¹	ASTM A240 UNS S31600 with Laminated Graphite Sheet for Valve Size ≤10"		
		ASTM B443 UNS N06625 with Laminated Graphite Sheet for Valve Size ≥12"		
	Seat Ring (CL 300) ¹	ASTM A240 UNS S31600 with Laminated Graphite Sheet for Valve Size ≤8"		
		ASTM B443 UNS N06625 with Laminated Graphite Sheet for Valve Size ≥10"		
B913b	Seat Ring Fasteners	ASTM A479 Type XM-19 HRc 35 Maximum w/ Hot Rolled / Cold Rolled Condition		
B103	Seat Ring Gasket	NR40 Nickel reinforced Graphite Sheet		
B206	Packing Set	Gland Packing Passivated Gland Packing Braided		
B105	Seat Ring Retainer	ASTM A240 TY 316L (UNS S31603) HRc 22 Maximum		
B137	Disc	ASTM A351 Grade CF8M/EN 1.4408 CMS-1040 HRc 22 Maximum		
B913	Disc Fasteners	ASTM A479 Type XM-19 HRc 35 Maximum w/ Hot Rolled / Cold Rolled Condition		
B138	Disc Seat	Solution Annealed 316L Stainless Steel HRc 22 Maximum		
B010	End Plate	ASTM A351 GR CF3M/EN 14408 C:0.03/14409 CMS-1040 HRc 22 Maximum		
B913a	End Plate Fasteners	ASTM A479 Type XM-19 HRc 35 Maximum w/ Hot Rolled / Cold Rolled Condition		
B015	End Plate Gasket	NR40 Nickel reinforced Graphite Sheet		
B213	Packing Flange	Solution Annealed 316L Stainless Steel HRc 22 Maximum		
B201	Packing Nut	A4-80 (ISO 3506) 316L		
B202	Packing Ring	ASTM A479 UNS S31603 Titanium Nitride Coated		
B200	Packing Stud	A4-80 (ISO 3506) 316L		
B123	Shaft ²	ASTM A479 Type XM-19 HRc 35 Maximum w/ Hot Rolled / Cold Rolled Condition		
B139	Thrust Pad	ASTM A479 UNS S31603 Titanium Nitride Coated		
B915	Thrust Pad Fastener	ASTM A479 Type XM-19 HRc 35 Maximum w/ Hot Rolled / Cold Rolled Condition		
B903	Dowel Pin	ASTM A479 Type XM-19 HRc 35 Maximum w/ Hot Rolled / Cold Rolled Condition		
Part No.	Temperature Range (in °C)	-196°C	-46°C	-29°C

Notes:

1. May change to Nitronic 50 metal seal, consult engineering.
2. Inconel will be substituted in the applications when required due to the differential pressure.

Cryogenic Materials of Construction

(Refer to parts list on page 14)

Valve Sizes: 3" to 20"

Body Ratings: ANSI Class 600

Temperature Range (in °F)		-320°F	-50°F	-20°F
Part No.	Description	Standard Materials		
B001	Body	ASTM A351 Grade CF8M/EN 1.4408 CMS-1040 HRc 22 Maximum		
B003	Cryogenic Extension	ASTM A351 Grade CF8M/EN 1.4408 CMS-1040 HRc 22 Maximum		
B015a	Body Gasket	316L Stainless Steel Spiral w/Gasket and Graphite Filler		
B002	Body Stud	ASTM A193 Grade B8 Class 2		
B014	Body Stud Nut	ASTM A194 Grade 8 HRc 22 Maximum		
B011	Bearing	ASTM A479 UNS S31603 Titanium Nitride Coated		
B011a	Sleeve	Solution Annealed 316L Stainless Steel HRc 22 Maximum		
B208	Bearing Protector	Die Formed Graphite		
B102	Seat Ring ¹	ASTM B443 UNS N06625 with Laminated Graphite Sheet		
B913b ³	Seat Ring Fasteners	ASTM A479 Type XM-19 HRc 35 Maximum w/ Hot Rolled / Cold Rolled Condition		
B913a ⁴				
B103	Seat Ring Gasket	SST100 - Tanged Stainless Steel Reinforced Graphite Sheet		
B206	Packing Set	Gland Packing Passivated Gland Packing Braided		
B105	Seat Ring Retainer	ASTM A240 TY 316L (UNS S31603) HRc 22 Maximum		
B137	Disc ⁵	ASTM A351 Grade CF8M/EN 1.4408 CMS-1040 HRc 22 Maximum		
B913	Disc Fasteners ⁵	ASTM A479 Type XM-19 HRc 35 Maximum w/ Hot Rolled / Cold Rolled Condition		
B138	Integrated Disc Seat and Disc Seat ⁶	ASTM A479 Type XM-19 HRc 35 Maximum w/ Hot Rolled / Cold Rolled Condition		
B929	Key ⁶	ASTM A479 Type XM-19 HRc 35 Maximum w/ Hot Rolled / Cold Rolled Condition		
B914	Grub Screw ⁶	ASTM B446 HRc 35 Maximum (UNS N0625) Hot Worked and Annealed		
B138	Disc Seat ⁵	Solution Annealed 316L Stainless Steel HRc 22 Maximum		
B010	End Plate	ASTM A351 GR CF3M/EN 14408 C:0.03/14409 CMS-1040 HRc 22 Maximum		
B913a	End Plate Fasteners	ASTM A479 Type XM-19 HRc 35 Maximum w/ Hot Rolled / Cold Rolled Condition		
B015	End Plate Gasket	SST100 - Tanged Stainless Steel Reinforced Graphite Sheet		
B213	Packing Flange	Solution Annealed 316L Stainless Steel HRc 22 Maximum		
B201	Packing Nut	A4-80 (ISO 3506) 316L		
B202	Packing Ring	ASTM A479 UNS S31603 Titanium Nitride Coated		
B200	Packing Stud	A4-80 (ISO 3506) 316L		
B123	Shaft ²	ASTM A479 Type XM-19 HRc 35 Maximum w/ Hot Rolled / Cold Rolled Condition		
B139	Thrust Pad	ASTM A479 UNS S31603 Titanium Nitride Coated		
B915	Thrust Pad Fastener	ASTM A479 Type XM-19 HRc 35 Maximum w/ Hot Rolled / Cold Rolled Condition		
B903	Dowel Pin	ASTM A479 Type XM-19 HRc 35 Maximum w/ Hot Rolled / Cold Rolled Condition		
Part No.	Temperature Range (in °C)	-196°C	-46°C	-29°C

Notes:

1. May change to Nitronic 50 metal seal, consult engineering.
2. Inconel will be substituted in the applications when required due to the differential pressure.
3. Used from 3" to 8" CL 600.
4. Used from 10" to 20" CL 600.
5. Not Available in 3" and 4" CL 600.
6. Available in 3" and 4" CL 600 only.

Exploded View Cryogenic

Part No.	Description
B001	Body
B002	Body Stud
B003	Cryogenic Extension
B010	End Plate
B011	Bearing
B011a	Sleeve
B014	Body Stud Nut
B015	End Plate Gasket
B015a	Body Gasket
B102	Seat Ring
B103	Seat Ring Gasket
B105	Seat Ring Retainer
B123	Shaft
B137	Disc
B138	Disc Seat
B139	Thrust Pad
B200	Full Threaded Stud
B201	Hex Nut
B202	Gland Packing Ring
B206	Gland Packing
B208	Bearing Protector
B213	Gland
B903	Dowel Pins
B913	Flange Hex Bolt
B913a	Flange Hex Bolt
B913b	Flange Hex Bolt
B913c	Hex Head Bolt
B914	Set Screw
B915	Cap Head Screw

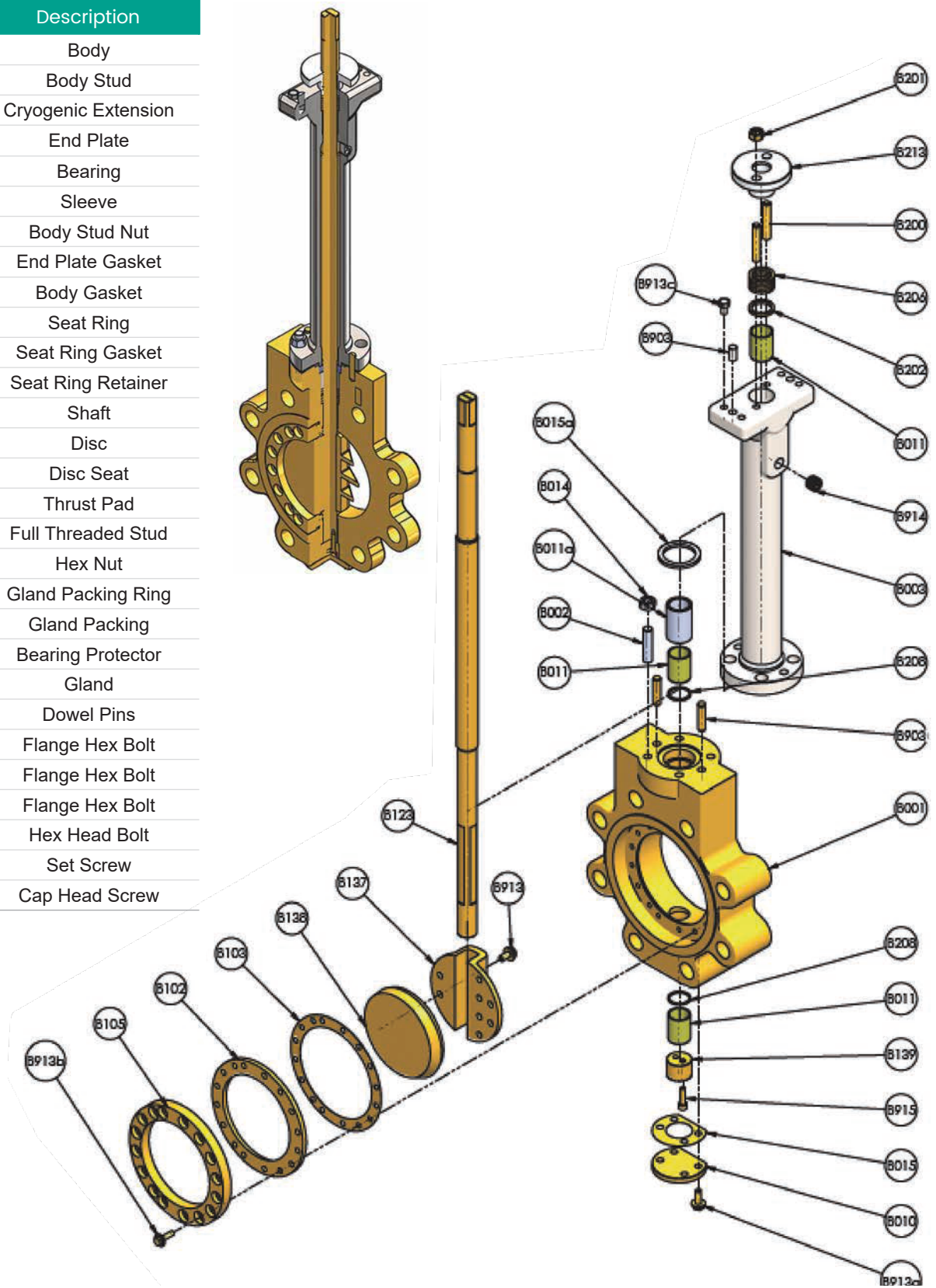

Rated Flow Coefficients

Flow to Close - ASME 150

Valve Size		ASME 150 - Valve Sizing Coefficient (Cv)										
		Disc Opening Percent										
Inches	mm		10	20	30	40	50	60	70	80	90	100
3"	80	Cv	2.2	6.1	12	19	30	43	58	74	90	98
		F _L	0.93	0.91	0.90	0.88	0.86	0.85	0.83	0.81	0.80	0.78
		X _T	0.73	0.70	0.68	0.65	0.63	0.60	0.58	0.56	0.53	0.51
4"	100	Cv	5	13	25	42	65	93	126	160	195	212
		F _L	0.93	0.91	0.90	0.88	0.86	0.84	0.82	0.81	0.79	0.77
		X _T	0.73	0.70	0.67	0.65	0.62	0.60	0.57	0.55	0.52	0.50
6"	150	Cv	14	38	72	119	186	269	362	460	560	610
		F _L	0.92	0.90	0.88	0.86	0.84	0.82	0.80	0.78	0.76	0.74
		X _T	0.71	0.68	0.65	0.62	0.59	0.57	0.54	0.51	0.49	0.46
8"	200	Cv	33	91	172	286	445	644	867	1103	1342	1461
		F _L	0.91	0.89	0.86	0.84	0.81	0.78	0.76	0.73	0.71	0.68
		X _T	0.70	0.66	0.62	0.59	0.55	0.52	0.48	0.45	0.42	0.39
10"	250	Cv	56	155	293	487	757	1097	1476	1878	2285	2488
		F _L	0.90	0.88	0.85	0.82	0.80	0.77	0.74	0.71	0.69	0.66
		X _T	0.68	0.64	0.61	0.57	0.53	0.50	0.46	0.43	0.40	0.37
12"	300	Cv	93	256	484	803	1248	1808	2433	3096	3767	4102
		F _L	0.89	0.86	0.83	0.81	0.78	0.75	0.72	0.69	0.66	0.63
		X _T	0.67	0.63	0.59	0.55	0.51	0.47	0.43	0.40	0.37	0.33
14"	350	Cv	118	326	615	1022	1588	2300	3096	3939	4793	5218
		F _L	0.88	0.85	0.81	0.78	0.74	0.71	0.67	0.64	0.60	0.57
		X _T	0.65	0.61	0.56	0.51	0.47	0.42	0.38	0.34	0.31	0.27
16"	400	Cv	153	422	796	1322	2055	2976	4007	5098	6203	6753
		F _L	0.87	0.84	0.80	0.77	0.73	0.69	0.66	0.62	0.59	0.55
		X _T	0.64	0.59	0.54	0.49	0.45	0.40	0.36	0.33	0.29	0.25
18"	450	Cv	198	548	1034	1717	2668	3864	5201	6618	8052	8767
		F _L	0.86	0.83	0.79	0.76	0.72	0.69	0.65	0.62	0.58	0.55
		X _T	0.62	0.58	0.53	0.48	0.44	0.40	0.36	0.32	0.29	0.25
20"	500	Cv	246	680	1282	2129	3310	4793	6452	8209	9989	10875
		F _L	0.85	0.82	0.79	0.75	0.72	0.69	0.65	0.62	0.58	0.55
		X _T	0.61	0.57	0.52	0.48	0.43	0.39	0.36	0.32	0.29	0.25
24"	600	Cv	357	986	1860	3090	4803	6955	9362	11912	14494	15780
		F _L	0.85	0.82	0.79	0.75	0.72	0.69	0.65	0.62	0.58	0.55
		X _T	0.61	0.57	0.52	0.48	0.43	0.39	0.36	0.32	0.29	0.25
30"	750	Cv	623	1721	3248	5394	8385	12142	16345	20797	25304	27550
		F _L	0.85	0.82	0.79	0.75	0.72	0.69	0.65	0.62	0.58	0.55
		X _T	.061	0.57	0.52	0.48	0.43	0.39	0.36	0.32	0.29	0.25
36"	900	Cv	898	2481	4680	7773	12083	17497	23554	29969	36464	39700
		F _L	0.85	0.82	0.79	0.75	0.72	0.69	0.65	0.62	0.58	0.55
		X _T	0.61	0.57	0.52	0.48	0.43	0.39	0.36	0.32	0.29	0.25
42"	1050	Cv	1277	3528	6656	11054	17182	24879	33492	42614	51849	56450
		F _L	0.85	0.82	0.79	0.75	0.72	0.69	0.65	0.62	0.58	0.55
		X _T	0.61	0.57	0.52	0.48	0.43	0.39	0.36	0.32	0.29	0.25
48"	1200	Cv	1669	4690	8695	14441	22447	32504	43756	55673	67739	73750
		F _L	0.85	0.82	0.79	0.75	0.72	0.69	0.65	0.62	0.58	0.55
		X _T	0.61	0.57	0.52	0.48	0.43	0.39	0.36	0.32	0.29	0.25

Rated Flow Coefficients

Flow to Open – ASME 150

Valve Size		ASME 150 - Valve Sizing Coefficient (Cv)										
		Disc Opening Percent										
Inches	mm		10	20	30	40	50	60	70	80	90	100
3"	80	Cv	4.5	8.7	14.6	22.6	33	47	63	81	93	94
		F _L	0.93	0.91	0.89	0.87	0.84	0.82	0.80	0.78	0.75	0.73
		X _T	0.73	0.70	0.66	0.63	0.60	0.56	0.53	0.50	0.48	0.45
4"	100	Cv	9.8	18.9	31.4	48.8	72	101	137	175	200	203
		F _L	0.93	0.91	0.89	0.87	0.84	0.82	0.80	0.78	0.75	0.73
		X _T	0.73	0.70	0.66	0.63	0.60	0.56	0.53	0.50	0.48	0.45
6"	150	Cv	28	54	90	140	207	291	392	502	573	582
		F _L	0.92	0.90	0.88	0.86	0.83	0.81	0.79	0.77	0.74	0.72
		X _T	0.71	0.68	0.65	0.61	0.58	0.55	0.52	0.49	0.46	0.44
8"	200	Cv	67	130	216	335	496	697	940	1205	1375	1396
		F _L	0.91	0.89	0.87	0.85	0.83	0.81	0.78	0.76	0.74	0.72
		X _T	0.70	0.67	0.64	0.60	0.57	0.55	0.52	0.49	0.46	0.44
10"	250	Cv	115	221	368	571	845	1187	1601	2051	2341	2377
		F _L	0.90	0.88	0.86	0.84	0.81	0.79	0.77	0.75	0.72	0.70
		X _T	0.68	0.65	0.62	0.59	0.55	0.52	0.49	0.47	0.44	0.41
12"	300	Cv	189	364	607	941	1392	1956	2639	3381	3858	3918
		F _L	0.89	0.87	0.85	0.83	0.80	0.78	0.76	0.74	0.71	0.69
		X _T	0.67	0.64	0.60	0.57	0.54	0.51	0.48	0.45	0.43	0.40
14"	350	Cv	241	464	772	1197	1771	2489	3358	4302	4908	4984
		F _L	0.88	0.86	0.84	0.82	0.79	0.77	0.75	0.73	0.70	0.68
		X _T	0.65	0.62	0.59	0.56	0.53	0.50	0.47	0.44	0.41	0.39
16"	400	Cv	311	600	999	1549	2292	3221	4346	5567	6353	6451
		F _L	0.87	0.85	0.83	0.81	0.78	0.76	0.74	0.72	0.69	0.67
		X _T	0.64	0.61	0.58	0.54	0.51	0.49	0.46	0.43	0.40	0.38
18"	450	Cv	404	779	1297	2011	2976	4182	5642	7227	8247	8375
		F _L	0.86	0.84	0.82	0.79	0.77	0.74	0.72	0.70	0.67	0.65
		X _T	0.62	0.59	0.56	0.53	0.50	0.47	0.44	0.41	0.38	0.35
20"	500	Cv	502	966	1609	2495	3692	5187	6998	8965	10230	10388
		F _L	0.85	0.83	0.81	0.79	0.76	0.74	0.72	0.70	0.67	0.65
		X _T	0.61	0.58	0.55	0.52	0.49	0.46	0.43	0.41	0.38	0.35
24"	600	Cv	728	1402	2335	3620	5357	7527	10154	13008	14844	15074
		F _L	0.85	0.83	0.81	0.79	0.76	0.74	0.72	0.70	0.67	0.65
		X _T	0.61	0.58	0.55	0.52	0.49	0.46	0.43	0.41	0.38	0.35
30"	750	Cv	966	1860	3098	4803	7107	9986	13473	17260	19695	20000
		F _L	0.85	0.83	0.81	0.79	0.76	0.74	0.72	0.70	0.67	0.65
		X _T	0.61	0.58	0.55	0.52	0.49	0.46	0.43	0.41	0.38	0.35
36"	900	Cv	1390	2678	4461	6916	10234	14380	19401	24854	28361	28800
		F _L	0.85	0.83	0.81	0.79	0.76	0.74	0.72	0.70	0.67	0.65
		X _T	0.61	0.58	0.55	0.52	0.49	0.46	0.43	0.41	0.38	0.35
42"	1050	Cv	2043	3934	6553	10159	15032	21121	28496	36504	41655	42300
		F _L	0.85	0.83	0.81	0.79	0.76	0.74	0.72	0.7	0.67	0.65
		X _T	0.61	0.58	0.55	0.52	0.49	0.46	0.43	0.41	0.38	0.35
48"	1200	Cv	2668	5139	8559	13269	19634	27587	37220	47680	54408	55250
		F _L	0.85	0.83	0.81	0.79	0.76	0.74	0.72	0.7	0.67	0.65
		X _T	0.61	0.58	0.55	0.52	0.49	0.46	0.43	0.41	0.38	0.35

Rated Flow Coefficients

Flow to Close - ASME 300

Valve Size		ASME 300 - Valve Sizing Coefficient (Cv)										
		Disc Opening Percent										
Inches	mm		10	20	30	40	50	60	70	80	90	100
3"	80	Cv	2.2	6.1	12	19	30	43	58	74	90	98
		F _L	0.93	0.91	0.90	0.88	0.86	0.85	0.83	0.81	0.80	0.78
		X _T	0.73	0.70	0.68	0.65	0.63	0.60	0.58	0.56	0.53	0.51
4"	100	Cv	5	13	25	42	65	93	126	160	195	212
		F _L	0.93	0.91	0.90	0.88	0.86	0.84	0.82	0.81	0.79	0.77
		X _T	0.73	0.70	0.67	0.65	0.62	0.60	0.57	0.55	0.52	0.50
6"	150	Cv	12	34	65	107	167	242	325	414	504	548
		F _L	0.92	0.90	0.88	0.86	0.84	0.82	0.80	0.78	0.76	0.74
		X _T	0.71	0.68	0.65	0.62	0.59	0.57	0.54	0.51	0.49	0.46
8"	200	Cv	30	82	155	257	400	580	780	993	1208	1315
		F _L	0.91	0.89	0.86	0.84	0.81	0.78	0.76	0.73	0.71	0.68
		X _T	0.70	0.66	0.62	0.59	0.55	0.52	0.48	0.45	0.42	0.39
10"	250	Cv	51	140	264	438	682	987	1328	1690	2057	2239
		F _L	0.90	0.88	0.85	0.82	0.80	0.77	0.74	0.71	0.69	0.66
		X _T	0.68	0.64	0.61	0.57	0.53	0.50	0.46	0.43	0.40	0.37
12"	300	Cv	84	231	435	723	1124	1627	2190	2787	3391	3691
		F _L	0.89	0.86	0.83	0.81	0.78	0.75	0.72	0.69	0.66	0.63
		X _T	0.67	0.63	0.59	0.55	0.51	0.47	0.43	0.40	0.37	0.33
14"	350	Cv	106	293	554	920	1429	2070	2786	3545	4314	4697
		F _L	0.88	0.85	0.81	0.78	0.74	0.71	0.67	0.64	0.60	0.57
		X _T	0.65	0.61	0.56	0.51	0.47	0.42	0.38	0.34	0.31	0.27
16"	400	Cv	137	380	717	1190	1850	2679	3606	4588	5582	6078
		F _L	0.87	0.84	0.80	0.77	0.73	0.69	0.66	0.62	0.59	0.55
		X _T	0.64	0.59	0.54	0.49	0.45	0.40	0.36	0.33	0.29	0.25
18"	450	Cv	178	493	930	1545	2402	3478	4682	5957	7248	7891
		F _L	0.86	0.83	0.79	0.76	0.72	0.69	0.65	0.62	0.58	0.55
		X _T	0.62	0.58	0.53	0.48	0.44	0.40	0.36	0.32	0.29	0.25
20"	500	Cv	221	612	1154	1916	2979	4313	5807	7388	8989	9787
		F _L	0.85	0.82	0.79	0.75	0.72	0.69	0.65	0.62	0.58	0.55
		X _T	0.61	0.57	0.52	0.48	0.43	0.39	0.36	0.32	0.29	0.25
24"	600	Cv	321	887	1674	2781	4323	6259	8426	10721	13045	14202
		F _L	0.85	0.82	0.79	0.75	0.72	0.69	0.65	0.62	0.58	0.55
		X _T	0.61	0.57	0.52	0.48	0.43	0.39	0.36	0.32	0.29	0.25
30"	750	Cv	561	1550	2924	4856	7548	10930	14714	18721	22778	24800
		F _L	0.85	0.82	0.79	0.75	0.72	0.69	0.65	0.62	0.58	0.55
		X _T	0.61	0.57	0.52	0.48	0.43	0.39	0.36	0.32	0.29	0.25
36"	900	Cv	809	2234	4215	7000	10881	15756	21210	26987	32836	35750
		F _L	0.85	0.82	0.79	0.75	0.72	0.69	0.65	0.62	0.58	0.55
		X _T	0.61	0.57	0.52	0.48	0.43	0.39	0.36	0.32	0.29	0.25
42"	1050	Cv	1150	3175	5991	9949	15465	22394	30146	38356	46669	50810
		F _L	0.85	0.82	0.79	0.75	0.72	0.69	0.65	0.62	0.58	0.55
		X _T	0.61	0.57	0.52	0.48	0.43	0.39	0.36	0.32	0.29	0.25
48"	1200	Cv	1502	4149	7829	13002	20210	29264	39395	50125	60988	66400
		F _L	0.85	0.82	0.79	0.75	0.72	0.69	0.65	0.62	0.58	0.55
		X _T	0.61	0.57	0.52	0.48	0.43	0.39	0.36	0.32	0.29	0.25

Rated Flow Coefficients

Flow to Open – ASME 300

Valve Size		ASME 300 - Valve Sizing Coefficient (Cv)										
		Disc Opening Percent										
Inches	mm		10	20	30	40	50	60	70	80	90	100
3"	80	Cv	4.5	8.7	14.6	22.6	33	47	63	81	93	94
		F _L	0.93	0.91	0.89	0.87	0.84	0.82	0.80	0.78	0.75	0.73
		X _T	0.73	0.70	0.66	0.63	0.60	0.56	0.53	0.50	0.48	0.45
4"	100	Cv	9.8	18.9	31.4	48.8	72	101	137	175	200	203
		F _L	0.93	0.91	0.89	0.87	0.84	0.82	0.80	0.78	0.75	0.73
		X _T	0.73	0.70	0.66	0.63	0.60	0.56	0.53	0.50	0.48	0.45
6"	150	Cv	25	49	81	126	186	261	353	452	516	524
		F _L	0.92	0.90	0.88	0.86	0.83	0.81	0.79	0.77	0.74	0.72
		X _T	0.71	0.68	0.65	0.61	0.58	0.55	0.52	0.49	0.46	0.44
8"	200	Cv	61	117	195	302	446	627	846	1084	1237	1256
		F _L	0.91	0.89	0.87	0.85	0.83	0.81	0.78	0.76	0.74	0.72
		X _T	0.70	0.67	0.64	0.60	0.57	0.55	0.52	0.49	0.46	0.44
10"	250	Cv	103	199	331	514	760	1068	1441	1846	2107	2139
		F _L	0.90	0.88	0.86	0.84	0.81	0.79	0.77	0.75	0.72	0.70
		X _T	0.68	0.65	0.62	0.59	0.55	0.52	0.49	0.47	0.44	0.41
12"	300	Cv	170	328	546	847	1253	1761	2375	3043	3472	3526
		F _L	0.89	0.87	0.85	0.83	0.80	0.78	0.76	0.74	0.71	0.69
		X _T	0.67	0.64	0.60	0.57	0.54	0.51	0.48	0.45	0.43	0.40
14"	350	Cv	217	417	695	1077	1594	2240	3022	3872	4418	4486
		F _L	0.88	0.86	0.84	0.82	0.79	0.77	0.75	0.73	0.70	0.68
		X _T	0.65	0.62	0.59	0.56	0.53	0.50	0.47	0.44	0.41	0.39
16"	400	Cv	280	540	899	1394	2063	2899	3911	5010	5717	5806
		F _L	0.87	0.85	0.83	0.81	0.78	0.76	0.74	0.72	0.69	0.67
		X _T	0.64	0.61	0.58	0.54	0.51	0.49	0.46	0.43	0.40	0.38
18"	450	Cv	364	701	1168	1810	2679	3764	5078	6505	7423	7538
		F _L	0.86	0.84	0.82	0.79	0.77	0.74	0.72	0.70	0.67	0.65
		X _T	0.62	0.59	0.56	0.53	0.50	0.47	0.44	0.41	0.38	0.35
20"	500	Cv	451	869	1448	2245	3322	4668	6298	8068	9206	9349
		F _L	0.85	0.83	0.81	0.79	0.76	0.74	0.72	0.70	0.67	0.65
		X _T	0.61	0.58	0.55	0.52	0.49	0.46	0.43	0.41	0.38	0.35
24"	600	Cv	655	1262	2101	3258	4821	6774	9139	11708	13360	13567
		F _L	0.85	0.83	0.81	0.79	0.76	0.74	0.72	0.70	0.67	0.65
		X _T	0.61	0.58	0.55	0.52	0.49	0.46	0.43	0.41	0.38	0.35
30"	750	Cv	869	1674	2788	4323	6396	8988	12126	15534	17726	18000
		F _L	0.85	0.83	0.81	0.79	0.76	0.74	0.72	0.70	0.67	0.65
		X _T	0.61	0.58	0.55	0.52	0.49	0.46	0.43	0.41	0.38	0.35
36"	900	Cv	1253	2413	4020	6232	9222	12957	17481	22394	25554	25950
		F _L	0.85	0.83	0.81	0.79	0.76	0.74	0.72	0.70	0.67	0.65
		X _T	0.61	0.58	0.55	0.52	0.49	0.46	0.43	0.41	0.38	0.35
42"	1050	Cv	1835	3534	5887	9126	13504	18974	25599	32794	37421	38000
		F _L	0.85	0.83	0.81	0.79	0.76	0.74	0.72	0.7	0.67	0.65
		X _T	0.61	0.58	0.55	0.52	0.49	0.46	0.43	0.41	0.38	0.35
48"	1200	Cv	2402	4627	7707	11948	17680	24841	33515	42934	48992	49750
		F _L	0.85	0.83	0.81	0.79	0.76	0.74	0.72	0.7	0.67	0.65
		X _T	0.61	0.58	0.55	0.52	0.49	0.46	0.43	0.41	0.38	0.35

Rated Flow Coefficients

Flow to Close - ASME 600

Valve Size		ASME 600 - Valve Sizing Coefficient (Cv)										
		Disc Opening Percent										
Inches	mm		10	20	30	40	50	60	70	80	90	100
3"	80	Cv	1.3	3.6	7	11	18	26	34	44	53	58
		F _L	0.93	0.91	0.90	0.88	0.86	0.85	0.836	0.81	0.80	0.78
		X _T	0.73	0.70	0.68	0.65	0.693	0.60	0.58	0.56	0.53	0.51
4"	100	Cv	2	5	10	17	26	37	50	64	78	85
		F _L	0.93	0.91	0.90	0.88	0.86	0.84	0.82	0.81	0.79	0.77
		X _T	0.73	0.70	0.67	0.65	0.62	0.60	0.57	0.55	0.52	0.50
6"	150	Cv	7	20	38	63	98	142	191	243	296	322
		F _L	0.92	0.90	0.88	0.86	0.84	0.82	0.80	0.78	0.76	0.74
		X _T	0.71	0.68	0.65	0.62	0.59	0.57	0.54	0.51	0.49	0.46
8"	200	Cv	19	54	101	168	261	377	508	646	787	856
		F _L	0.91	0.89	0.86	0.84	0.81	0.78	0.76	0.73	0.71	0.68
		X _T	0.70	0.66	0.62	0.59	0.55	0.52	0.48	0.45	0.42	0.39
10"	250	Cv	31	87	163	272	422	611	823	1047	1274	1387
		F _L	0.90	0.88	0.85	0.82	0.80	0.77	0.74	0.71	0.69	0.66
		X _T	0.68	0.4	0.61	0.57	0.53	0.50	0.46	0.43	0.40	0.37
12"	300	Cv	45	123	232	386	599	868	1168	1487	1809	1969
		F _L	0.89	0.86	0.83	0.81	0.78	0.75	0.72	0.69	0.66	0.63
		X _T	0.67	0.63	0.59	0.55	0.51	0.47	0.43	0.40	0.37	0.33
14"	350	Cv	55	152	287	477	741	1073	1444	1838	2236	2434
		F _L	0.88	0.85	0.81	0.78	0.74	0.71	0.67	0.64	0.60	0.57
		X _T	0.65	0.61	0.56	0.51	0.47	0.42	0.38	0.34	0.31	0.27
16"	400	Cv	64	178	336	558	867	1255	1690	2150	2616	2848
		F _L	0.87	0.84	0.80	0.77	0.73	0.69	0.66	0.62	0.59	0.558
		X _T	0.64	0.59	0.54	0.49	0.45	0.40	0.36	0.33	0.29	0.25
18"	450	Cv	85	235	444	738	1147	1661	2235	2844	3461	3768
		F _L	0.86	0.83	0.79	0.76	0.72	0.69	0.65	0.62	0.58	0.55
		X _T	0.62	0.52	0.53	0.48	0.44	0.40	0.36	0.32	0.29	0.25
20"	500	Cv	122	336	635	1054	1638	2372	3194	4063	4944	5383
		F _L	0.85	0.82	0.79	0.75	0.72	0.69	0.65	0.62	0.58	0.55
		X _T	0.61	0.57	0.52	0.48	0.43	0.39	0.36	0.32	0.29	0.25

Rated Flow Coefficients

Flow to Open – ASME 600

Valve Size		ASME 600 - Valve Sizing Coefficient (Cv)										
		Disc Opening Percent										
Inches	mm		10	20	30	40	50	60	70	80	90	100
3"	80	Cv	2.7	5.2	8.6	13.3	20	28	37	48	55	56
		F _L	0.93	0.91	0.89	0.87	0.84	0.82	0.80	0.78	0.75	0.73
		X _T	0.73	0.70	0.66	0.63	0.60	0.56	0.53	0.50	0.48	0.45
4"	100	Cv	3.9	7.5	12.6	19	29	40	55	70	80	81
		F _L	0.93	0.91	0.89	0.87	0.84	0.82	0.80	0.78	0.75	0.73
		X _T	0.73	0.70	0.66	0.63	0.60	0.56	0.53	0.50	0.48	0.45
6"	150	Cv	15	29	48	74	109	153	207	265	303	307
		F _L	0.92	0.90	0.88	0.86	0.83	0.81	0.79	0.77	0.74	0.72
		X _T	0.71	0.68	0.65	0.61	0.58	0.55	0.52	0.49	0.46	0.44
8"	200	Cv	40	76	127	197	291	409	551	706	806	818
		F _L	0.91	0.89	0.87	0.85	0.83	0.81	0.78	0.76	0.74	0.72
		X _T	0.70	0.67	0.64	0.60	0.57	0.55	0.52	0.49	0.46	0.44
10"	250	Cv	64	123	205	318	471	661	892	1143	1305	1325
		F _L	0.90	0.88	0.86	0.84	0.81	0.79	0.77	0.75	0.72	0.70
		X _T	0.68	0.65	0.62	0.59	0.55	0.52	0.49	0.47	0.44	0.41
12"	300	Cv	91	175	291	452	668	939	1267	1623	1852	1881
		F _L	0.89	0.87	0.85	0.83	0.80	0.78	0.76	0.74	0.71	0.69
		X _T	0.67	0.64	0.60	0.57	0.54	0.51	0.48	0.45	0.43	0.40
14"	350	Cv	112	216	360	558	826	1161	1566	2007	2290	2325
		F _L	0.88	0.86	0.84	0.82	0.79	0.77	0.75	0.76	0.70	0.68
		X _T	0.65	0.62	0.59	0.56	0.53	0.50	0.47	0.44	0.41	0.39
16"	400	Cv	131	253	421	653	967	1358	1833	2348	2679	2720
		F _L	0.87	0.85	0.83	0.81	0.78	0.76	0.74	0.72	0.69	0.67
		X _T	0.64	0.61	0.58	0.51	0.51	0.49	0.46	0.43	0.40	0.38
18"	450	Cv	174	335	557	864	1279	1797	2425	3106	3544	3599
		F _L	0.86	0.84	0.82	0.79	0.77	0.74	0.77	0.70	0.67	0.65
		X _T	0.62	0.59	0.56	0.53	0.50	0.47	0.44	0.41	0.38	0.35
20"	500	Cv	248	478	796	1235	1827	2567	3464	4437	5063	5142
		F _L	0.85	0.83	0.81	0.79	0.76	0.74	0.72	0.70	0.67	0.65
		X _T	0.61	0.58	0.55	0.52	0.49	0.46	0.43	0.41	0.38	0.35

Weights and Dimensions

Face to Face Dimension Table

Valve Size	Class	LUG / WAFER		DFSP	
		mm	inch	mm	inch
3"	150	48.0	1.89	114.0	4.49
	300	48.0	1.89	114.0	4.49
	600	54.0	2.13	180.0	7.09
4"	150	54.0	2.13	127.0	5.00
	300	54.0	2.13	127.0	5.00
	600	64.0	2.52	190.0	7.48
6"	150	58.0	2.28	140.0	5.51
	300	60.0	2.36	140.0	5.51
	600	78.0	3.07	210.0	8.27
8"	150	63.5	2.50	152.0	5.98
	300	73.0	2.87	152.0	5.98
	600	102.0	4.02	230.0	9.06
10"	150	71.0	2.80	165.0	6.50
	300	83.0	3.27	165.0	6.50
	600	117.0	4.61	250.0	9.8
12"	150	81.0	3.19	178.0	7.01
	300	92.0	3.62	178.0	7.01
	600	140.0	5.51	270.0	10.63
14"	150	92.0	3.62	190.0	7.48
	300	117.0	4.61	190.0	7.48
	600	155.0	6.10	290.0	11.42
16"	150	102.0	4.02	216.0	8.50
	300	133.0	5.24	216.0	8.50
	600	178.0	7.01	31.00	12.20
18"	150	114.0	4.49	222.0	8.74
	300	149.0	5.87	222.0	8.74
	600	200.0	7.87	330.0	12.99
20"	150	127.0	5.00	229.0	9.02
	300	159.0	6.26	229.0	9.02
	600	216.0	8.50	350.0	13.78
24"	150	154.0	6.06	267.0	10.51
	300	181.0	7.13	267.0	10.51
30"	150	190.0	7.48	318.0	12.52
	300	215.0	8.46	318.0	12.52
36"	150	203.0	7.99	330.0	12.99
	300	252.0	9.92	330.0	12.99
42"	150	251.0	9.88	410.0	16.14
	300	290.0	11.42	410.0	16.14
48"	150	276.0	10.87	470.0	18.50
	300	320.0	12.60	470.0	18.50

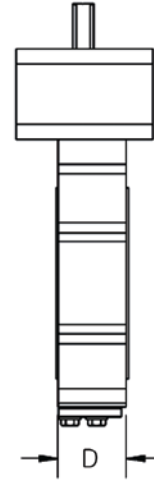

Lug

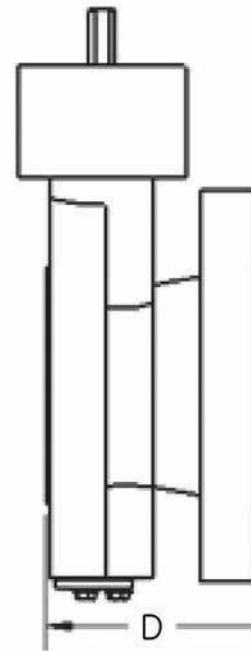

Double Flanged (Short Pattern) (DFSP)

Actuator Data – Model 33

3” to 8” inch Valve (DN 80 – DN 200) with Masoneilan Rotary Actuator

Type: Spring-diaphragm, floating stem pneumatic actuator

Action: Increasing air extends stem

Bench Range:
 B size 7-16 psig (48-110 kPa)
 C size 9-16 psig (62-110 kPa)

Connection: 1/4” NPT

Fail Safe Action: Field reversible

Yoke: Carbon steel

Bracket: Cast iron

Handwheel: (optional) Push type tilting, rising stem, permanently lubricated materials: 17-4 PH and AISI 416 stainless steel optional adjustable limit stops

Bracket Bearing: A sealed, permanently lubricated ball bearing

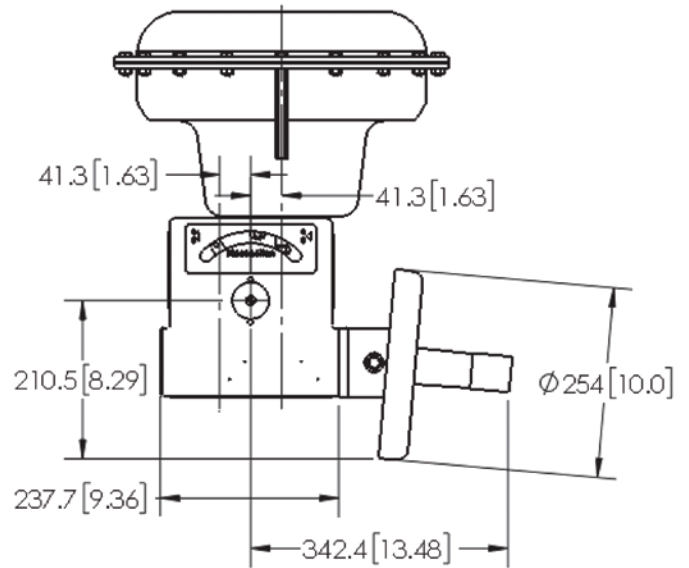
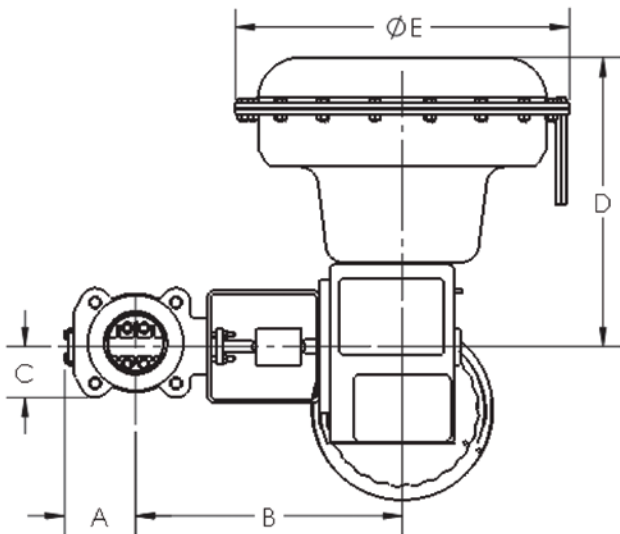

Valve Dimensions with Actuator Model 33

Actuator Data - Model 31/32

3" to 8" inch Valve (DN 80 - DN 200) with Masoneilan Rotary Actuator

Type:

Spring return, rolling diaphragm pneumatic actuator

Fail Safe Action:

Field reversible

Action:

Increasing air extends stem

Yoke:

Carbon steel

Bench Range:

12-28 psig (83-193 kPa), 17-40 psig (117-276 kPa) or
29-68 psig (200-469 kPa)

Manual Override:

(optional) Gear type mechanical jack-screw

Adjustable Limit Stops

Connection:

1/4" NPT

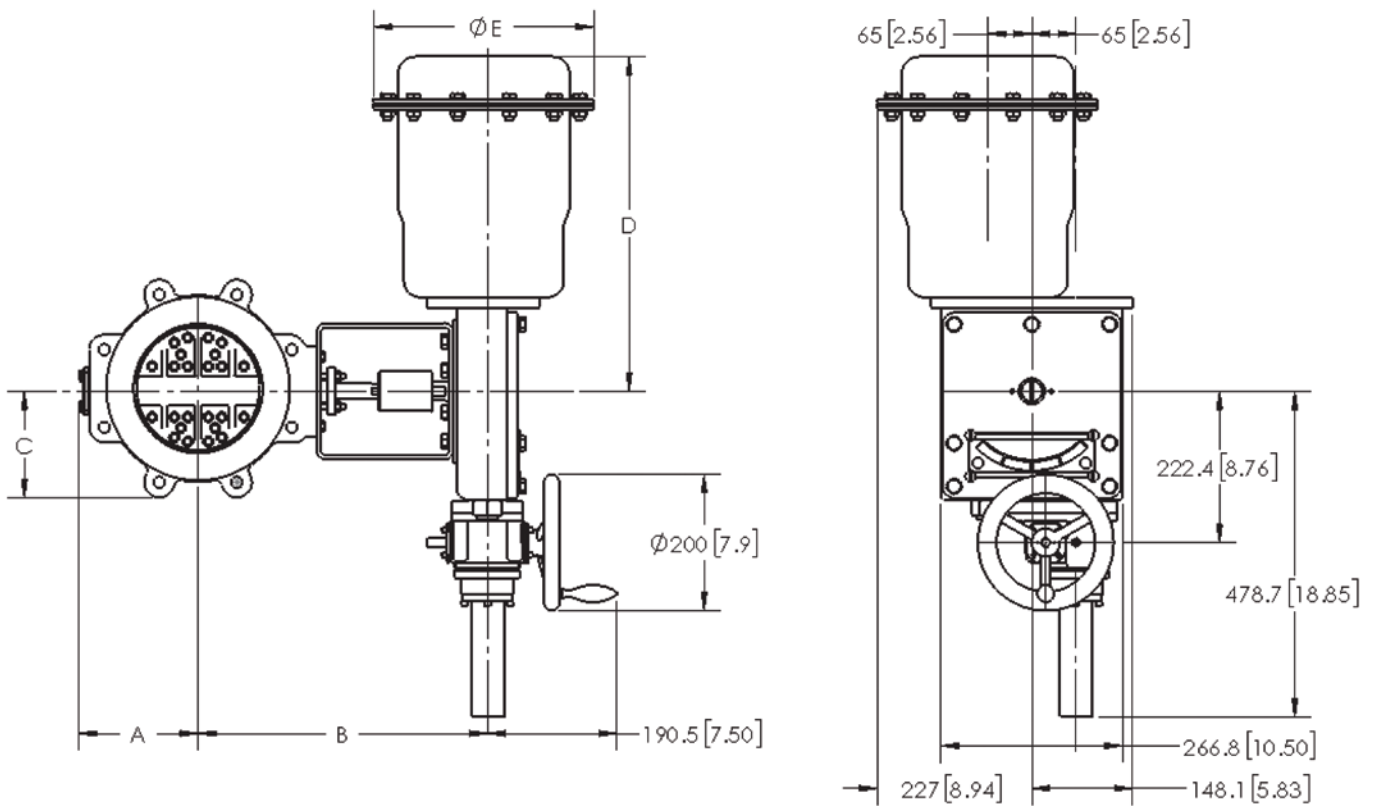

Valve Dimensions with Actuator Model 31/32 Size D

Actuator Data – Models 33 & 31/32

Dimensions

Valve Size		Class	Actuator Size	A		B				C		D		E	
						Standard		Cryogenic							
Inches	DN			inches	mm	inches	mm	inches	mm	inches	mm	inches	mm	inches	mm
3	80	150	33B	3.72	94.5	14.00	355.6	30.21	767.2	3.75	95.3	11.60	294.6	13.00	330.2
		300	33C	4.51	114.5	14.30	363.2	30.60	777.3	4.13	105.0	15.20	386.1	17.50	444.5
4	100	150	33C	4.70	119.5	14.90	378.5	31.00	787.3	4.51	114.5	15.20	386.1	17.50	444.5
		300	31/32 D	5.89	149.5	14.60	370.8	29.45	748.1	5.02	127.5	19.40	492.8	12.75	323.9
6	150	150	31/32 D	5.93	150.5	15.60	396.2	33.23	844.0	5.51	140.0	19.40	492.8	12.75	323.9
		300	31/32 D	6.85	174.0	17.00	431.8	34.04	864.6	6.25	158.8	19.40	492.8	12.75	323.9
8	200	150	31/32 D	6.89	175.0	16.60	421.6	35.05	890.4	6.75	171.5	19.40	492.8	12.75	323.9
		300	31/32 D	7.93	201.5	17.70	449.6	36.35	923.4	7.48	190.0	19.40	492.8	12.75	323.9

Actuator Data – CP/GP Series

8” to 48” inch Valve (DN 200 – DN 1200) with Masoneilan Cylinder Actuator

Type:	Scotch-yoke piston actuator	Housing:	Ductile iron
Action:	Spring-return or Double acting	Yoke:	Carbon steel
Connection:	1/4 in, 1/2 in, or 1 in NPT (depending on size)	Manual Override:	(optional) push type mechanical handwheel (GP130 and GP161 use a hydraulic hand pump)
Fail Safe Action:	Fail open or fail closed – spring return units	Adjustable limit stops (standard)	

CP Series Dimensional Drawing

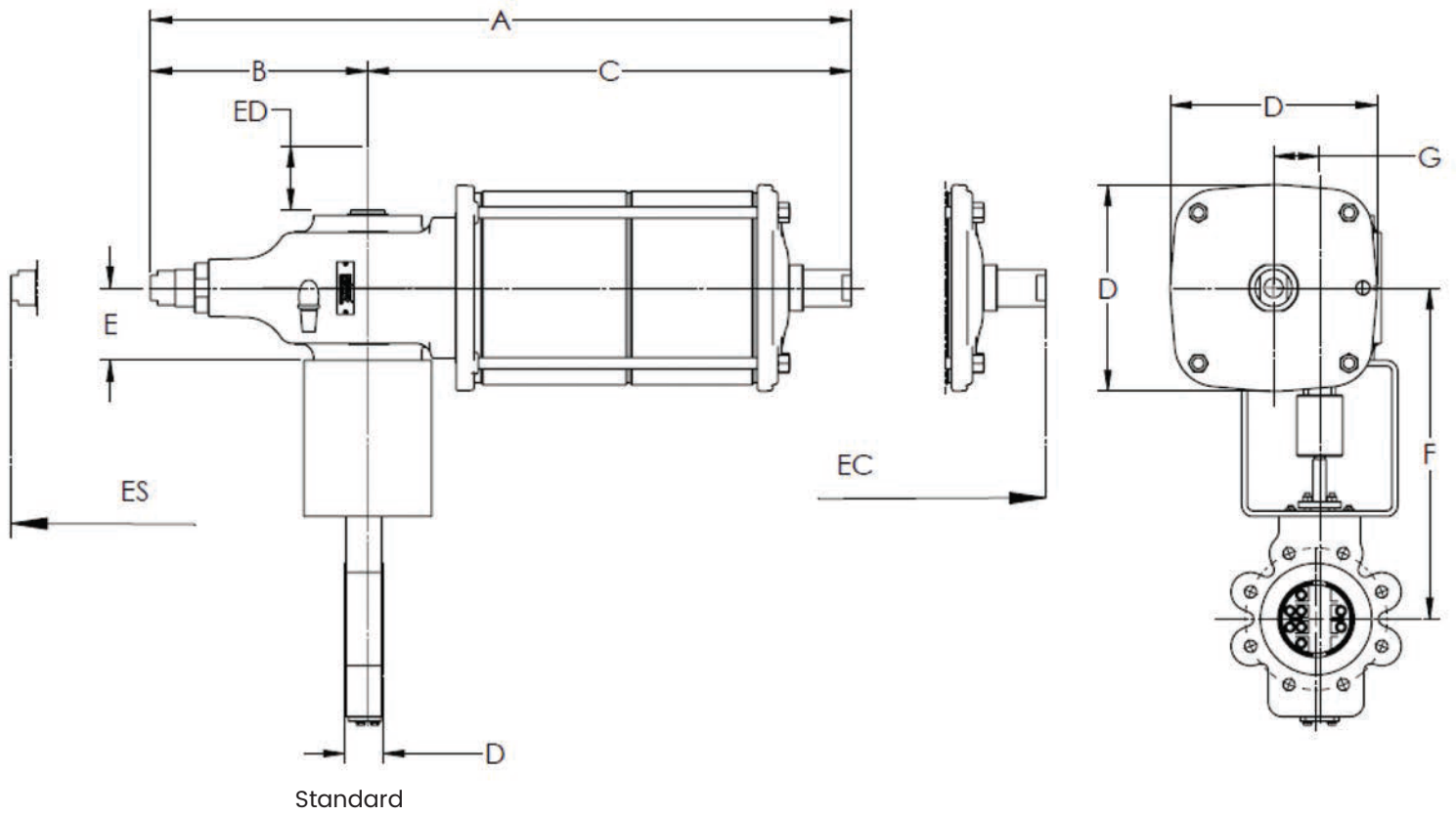

Actuator Data – CP Series Dimensions

Valve Size & Rating	Fail Position	Actuator Model	A		B		C		D		E		F				G	
			Standard		Cryogenic													
			mm	inch	mm	inch	mm	inch	mm	inch	mm	inch	mm	inch	mm	inch	mm	inch
8" 150	FO/FC	CP/S-045-180A/EL	731.0	28.78	216.5	8.52	514.5	20.26	194.0	7.64	61.25	2.411	400.0	15.75	868.8	34.20	45.0	1.77
8" 300	FO/FC	CP/S-055-250A/EA	841.5	33.13	274.5	10.81	567.0	22.32	291.0	11.46	72.00	2.835	485.0	19.09	958.8	37.75	55.0	2.17
10" 150	FO/FC	CP/S-055-250A/EA	841.5	33.13	274.5	10.81	567.0	22.32	291.0	11.46	72.00	2.835	505.0	19.88	1021.3	40.21	55.0	2.17
10" 300	FO/FC	CP/S-065-335A/CA	952.0	37.48	306.0	12.05	646.0	25.43	426.5	16.79	102.00	4.016	585.0	23.03	1091.3	42.97	65.0	2.56
12" 150	FO/FC	CP/S-065-250A/AA	952.0	37.48	306.0	12.05	646.0	25.43	291.0	11.46	102.00	4.016	587.0	23.11	1110.8	43.73	65.0	2.56
12" 300	FO/FC	CP/S-065-385A/EA	1046.0	41.18	306.0	12.05	740.0	29.13	446.0	17.56	102.00	4.016	642.0	25.28	1171.2	46.11	65.0	2.56
14" 150	FO/FC	CP/S-065-335A/CA	952.0	37.48	306.0	12.05	646.0	25.43	426.5	16.79	102.00	4.016	625.0	24.61	1210.7	47.67	65.0	2.56
3" 600	FO/FC	CP/S-045-180A/CL	731.0	28.78	216.5	8.52	514.5	20.26	194.0	7.64	61.25	2.411	361.3	14.22	737.0	29.02	45.0	1.77
4" 600	FO	CP/S-055-200A/AA	838.0	32.99	274.5	10.81	563.5	22.19	233.5	9.19	72.00	2.835	460.5	18.13	865.7	34.08	55.0	2.17
4" 600	FC	CP/S-055-250A/CA	841.5	33.13	274.5	10.81	567.0	22.32	291.0	11.46	72.00	2.835	460.5	18.13	865.7	34.08	55.0	2.17
6" 600	FO	CP/S-065-280A/AA	952.0	37.48	306.0	12.05	646.0	25.43	325.0	12.80	102.00	4.016	550.5	21.67	995.7	39.20	65.0	2.56
6" 600	FC	CP/S-065-335A/CA	952.0	37.48	306.0	12.05	646.0	25.43	426.5	16.79	102.00	4.016	550.5	21.67	995.7	39.20	65.0	2.56
8" 600	FO	CP/S-065-335A/CA	952.0	37.48	306.0	12.05	646.0	25.43	426.5	16.79	102.00	4.016	620.0	24.41	1109.6	43.69	65.0	2.56

Valve Size & Rating	Fail Position	Actuator Model	Clearance for Disassembly						Weight											
			ES		EC		ED		Standard						Cryogenic					
			mm	inch	mm	inch	mm	inch	LUG/WAFER		DFSP		DFLP		LUG/WAFER		DFSP		DFLP	
									Kg	Lbs	Kg	Lbs	Kg	Lbs	Kg	Lbs	Kg	Lbs	Kg	Lbs
8" 150	FO/FC	CP/S-045-180A/EL	95.0	3.74	70.0	2.76	160.8	6.33	71	157	94	206	103	226	79	174	101	223	110	243
8" 300	FO/FC	CP/S-055-250A/EA	100.0	3.94	100.0	3.94	200.8	7.91	144	317	178	393	199	439	155	342	189	417	210	464
10" 150	FO/FC	CP/S-055-250A/EA	100.0	3.94	100.0	3.94	195.8	7.71	147	325	176	388	186	409	160	352	189	416	198	437
10" 300	FO/FC	CP/S-065-335A/CA	100.0	3.94	100.0	3.94	200.8	7.91	251	554	294	649	330	728	266	586	309	681	344	759
12" 150	FO/FC	CP/S-065-250A/AA	100.0	3.94	100.0	3.94	200.8	7.91	202	444	238	524	258	569	215	474	251	554	272	599
12" 300	FO/FC	CP/S-065-385A/EA	100.0	3.94	100.0	3.94	225.8	8.89	348	767	402	887	452	997	374	824	428	944	478	1054
14" 150	FO/FC	CP/S-065-335A/CA	100.0	3.94	100.0	3.94	200.8	7.91	281	619	335	739	354	780	304	670	359	791	377	832
3" 600	FO/FC	CP/S-045-180A/CL	95.0	3.74	70.0	2.76	160.8	6.33	51	112	58	129	66	146	57	126	64	142	72	160
4" 600	FO	CP/S-055-200A/AA	100.0	3.94	100.0	3.94	200.8	7.91	94	208	106	234	121	267	105	231	117	257	132	291
4" 600	FC	CP/S-055-250A/CA	100.0	3.94	100.0	3.94	200.8	7.91	116	256	128	282	143	315	127	280	139	306	154	339
6" 600	FO	CP/S-065-280A/AA	100.0	3.94	100.0	3.94	200.8	7.91	186	409	234	515	254	559	199	439	247	545	267	589
6" 600	FC	CP/S-065-335A/CA	100.0	3.94	100.0	3.94	200.8	7.91	224	493	272	599	292	643	237	523	285	629	305	673
8" 600	FO	CP/S-065-335A/CA	100.0	3.94	100.0	3.94	225.8	8.89	264	581	328	722	370	816	289	637	353	778	395	872

CP Series Dimensional Drawing with Manual Operator

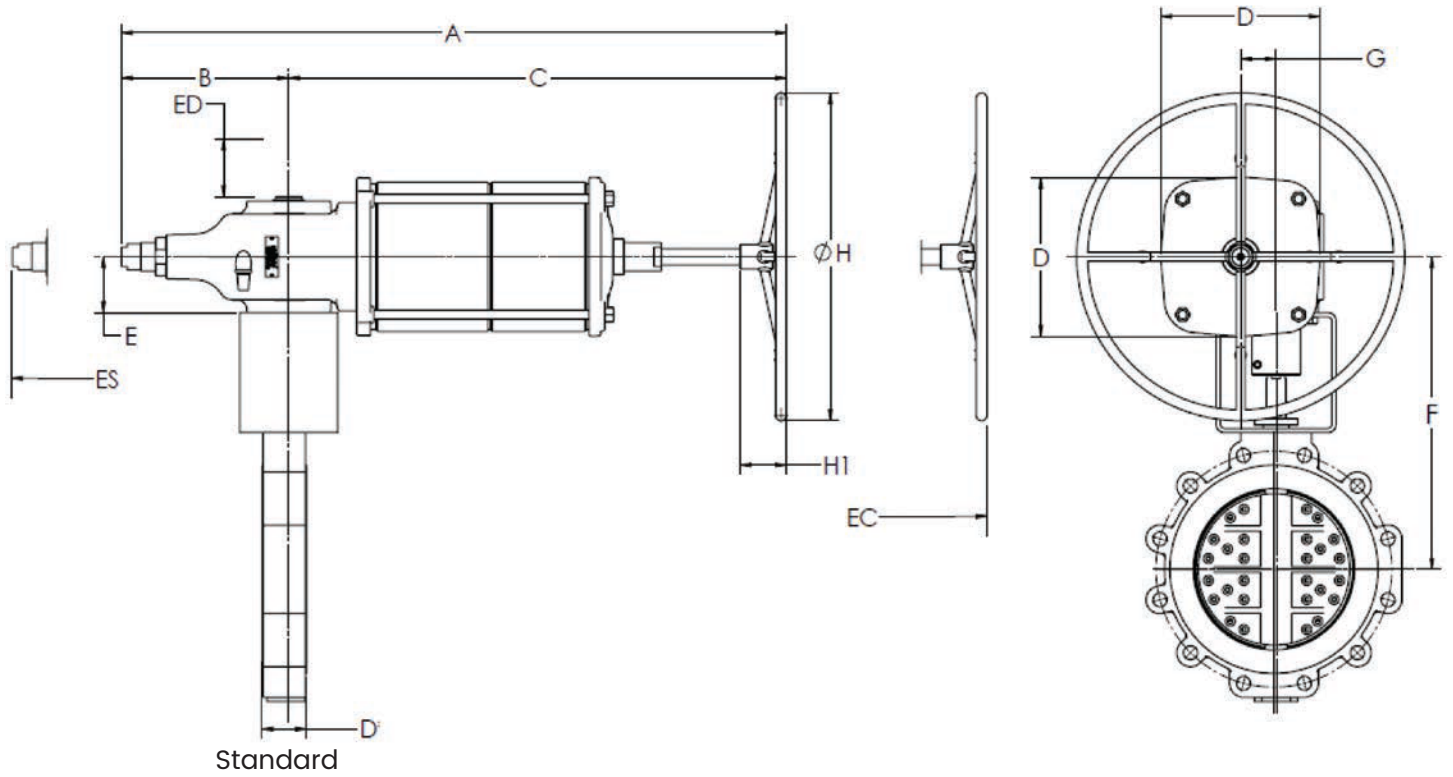

Actuator Data

CP Series Dimensions With Manual Operator

Valve Size & Rating	Fail Position	Actuator Model	A		B		C		D		E		F				G		ØH		H1	
			mm	inch	mm	inch	mm	inch	mm	inch	mm	inch	Standard		Cryogenic		mm	inch	mm	inch	mm	inch
													mm	inch	mm	inch						
8" 150	FO/FC	CP/S-045-180A/EL MH	957.5	37.70	216.50	8.52	741.0	29.17	209.5	8.25	61.25	2.411	400.0	15.75	868.8	34.20	45.0	1.77	380.0	14.96	97.0	3.82
8" 300	FO/FC	CP/S-055-250A/EA MH	1077.5	42.42	274.50	10.81	803.0	31.61	291.0	11.46	72.00	2.835	485.0	19.09	958.8	37.75	55.0	2.17	390.0	15.35	64.0	2.52
10" 150	FO/FC	CP/S-055-250A/EA MH	1077.5	42.42	274.50	10.81	803.0	31.61	291.0	11.46	72.00	2.835	505.0	19.88	1021.3	40.21	55.0	2.17	390.0	15.35	64.0	2.52
10" 300	FO/FC	CP/S-065-335A/CA MH	1217.5	47.93	306.00	12.05	911.5	35.89	426.5	16.79	102.00	4.016	585.0	23.03	1091.3	42.97	65.0	2.56	600.0	23.62	53.0	2.09
12" 150	FO/FC	CP/S-065-250A/AA MH	1215.5	47.85	306.00	12.05	909.5	35.81	291.0	11.46	102.00	4.016	587.0	23.11	1110.8	43.73	65.0	2.56	600.0	23.62	53.0	2.09
12" 300	FO/FC	CP/S-065-385A/EA MH	1333.5	52.50	306.00	12.05	1027.5	40.45	446.0	17.56	102.00	4.016	642.0	25.28	1171.2	46.11	65.0	2.56	600.0	23.62	53.0	2.09
14" 150	FO/FC	CP/S-065-335A/CA MH	1217.5	47.93	306.00	12.05	911.5	35.89	426.5	16.79	102.00	4.016	625.0	24.61	1210.7	47.67	65.0	2.56	600.0	23.62	53.0	2.09
3" 600	FO/FC	CP/S-045-180A/CL MH	957.5	37.70	216.50	8.52	741.0	29.17	194.0	7.64	61.25	2.411	361.3	14.22	737.0	29.02	45.0	1.77	380.0	14.96	97.0	3.82
4" 600	FO	CP/S-055-200A/AA MH	1073.0	42.24	274.50	10.81	799.5	31.48	233.5	9.19	72.00	2.835	460.5	18.13	865.7	34.08	55.0	2.17	390.0	15.35	64.0	2.52
4" 600	FC	CP/S-055-250A/CA MH	1077.5	42.42	274.50	10.81	803.0	31.61	291.0	11.46	72.00	2.835	460.5	18.13	865.7	34.08	55.0	2.17	390.0	15.35	64.0	2.52
6" 600	FO	CP/S-065-280A/AA MH	1224.5	48.21	306.00	12.05	918.5	36.16	325.0	12.80	102.00	4.016	550.5	21.67	995.7	39.20	65.0	2.56	600.0	23.62	53.0	2.09
6" 600	FC	CP/S-065-335A/CA MH	1217.5	47.93	306.00	12.05	911.5	35.89	426.5	16.79	102.00	4.016	550.5	21.67	995.7	39.20	65.0	2.56	600.0	23.62	53.0	2.09
8" 600	FO	CP/S-065-335A/CA MH	1217.5	47.93	306.00	12.05	911.5	35.89	426.5	16.79	102.00	4.016	620.0	24.41	1109.6	43.69	65.0	2.56	600.0	23.62	53.0	2.09

Actuator Data

CP Series Dimensions with Manual Operator

Valve Size & Rating	Fail Position	Actuator Model	Clearance for Disassembly						Weight											
			ES		EC		ED		Standard						Cryogenic					
									Lug/Wafer		DFSP		DFLP		Lug/Wafer		DFSP		DFLP	
			mm	inch	mm	inch	mm	inch	Kg	Lbs	Kg	Lbs	Kg	Lbs	Kg	Lbs	Kg	Lbs	Kg	Lbs
8" 150	FO/FC	CP/S-045-180A/EL MH	95.0	3.74	227.0	8.94	180.8	7.12	.75	165	97	214	106	234	82	182	104	230	114	250
8" 300	FO/FC	CP/S-055-250A/EA MH	120.0	4.72	225.0	8.86	220.8	8.69	148	326	182	402	203	448	159	351	193	426	214	473
10" 150	FO/FC	CP/S-055-250A/EA MH	120.0	4.72	225.0	8.86	215.8	8.50	151	334	180	397	190	418	164	361	193	424	202	445
10" 300	FO/FC	CP/S-065-335A/CA MH	120.0	4.72	250.0	9.84	220.8	8.69	257	568	300	662	336	741	272	599	315	694	350	773
12" 150	FO/FC	CP/S-065-250A/AA MH	120.0	4.72	250.0	9.84	220.8	8.69	208	458	244	537	264	583	221	487	257	567	278	613
12" 300	FO/FC	CP/S-065-385A/EA MH	120.0	4.72	250.0	9.84	245.8	9.68	354	780	408	900	458	1010	380	837	434	957	484	1067
14" 150	FO/FC	CP/S-065-335A/CA MH	120.0	4.72	250.0	9.84	220.8	8.69	287	632	341	753	360	794	310	684	365	804	383	845
3" 600	FO/FC	CP/S-045-180A/CL MH	95.0	3.74	227.0	8.94	180.8	7.12	53	117	62	136	70	154	59	130	68	150	76	168
4" 600	FO	CP/S-055-200A/AA MH	120.0	4.72	225.0	8.86	220.8	8.69	98	217	110	243	125	276	109	240	121	566	136	299
4" 600	FC	CP/S-055-250A/CA MH	120.0	4.72	225.0	8.86	220.8	8.69	120	265	132	291	147	324	131	289	143	315	158	348
6" 600	FO	CP/S-065-280A/AA MH	120.0	4.72	250.0	9.84	220.8	8.69	192	423	240	528	260	572	205	453	253	558	273	602
6" 600	FC	CP/S-065-335A/CA MH	120.0	4.72	250.0	9.84	220.8	8.69	230	506	278	612	298	656	243	536	291	642	311	686
8" 600	FO	CP/S-065-335A/CA MH	120.0	4.72	250.0	9.84	245.8	9.68	270	594	334	735	376	829	295	650	359	791	401	885

GP Series Dimensional Drawing

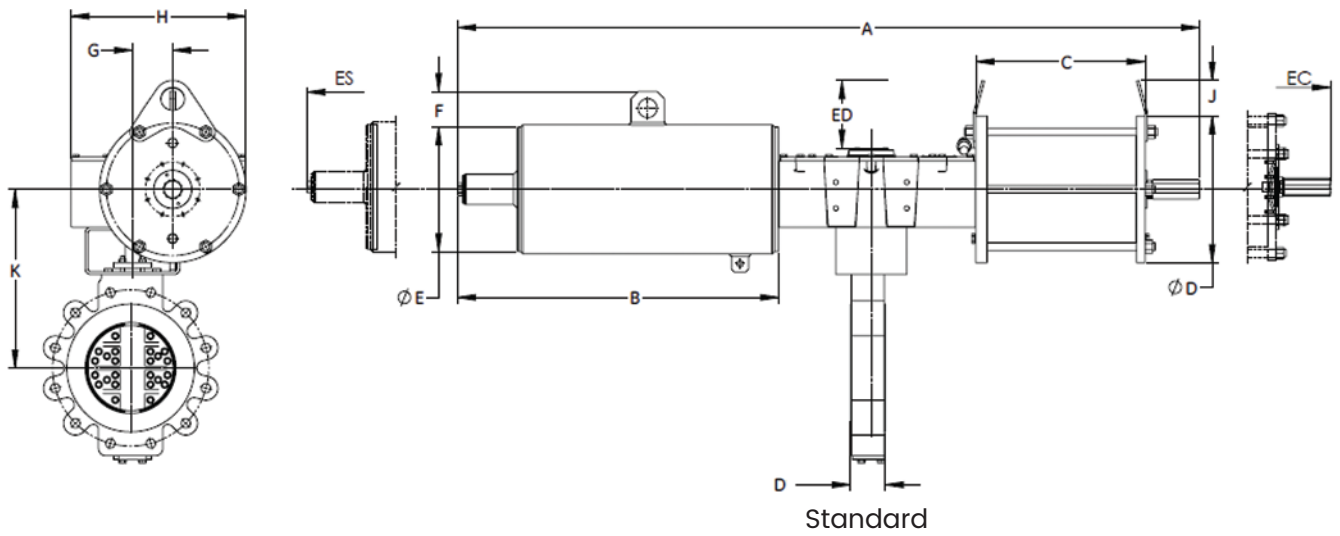

GP Series dimensional drawing

Actuator Data - GP Series Dimensions

Valve Size & Rating	Fail Close Actuator Model	Actuator Overall Dimensions																	
		A		B		C		ØD		ØE		F		G		H		J	
		mm	inch	mm	inch	mm	inch	mm	inch	mm	inch	mm	inch	mm	inch	mm	inch	mm	inch
8" 600	GP-085S-335A/C4D	1595.5	62.81	685.5	26.99	378.0	14.88	415.0	16.34	323.9	12.75	70.0	2.76	85.0	3.35	422.5	16.63	70.0	2.76
10" 600	GP-100S-485A/C1D	2048.0	80.63	871.0	34.29	525.0	20.67	570.0	22.44	406.4	16.00	70.0	2.76	100.0	3.94	545.0	21.46	115.0	4.53
12" 600	GP-100S-535A/C2D	2033.0	80.04	829.0	32.64	525.0	20.67	620.0	24.41	406.4	16.00	70.0	2.76	100.0	3.94	570.0	22.44	80.0	3.15
14" 300	GP-085C-385A/C2D	1595.5	62.81	672.5	26.48	381.0	15.00	465.0	18.31	273.0	10.75	70.0	2.76	85.0	3.35	447.5	17.62	80.0	3.15
14" 600	GP-130C-535A/C1D	2304.0	90.71	1003.0	39.49	525.0	20.67	620.0	24.41	457.2	18.00	100.0	3.94	130.0	5.12	601.5	23.68	80.0	3.15
16" 150	GP-085C-335A/C2D	1582.5	62.30	672.5	26.48	378.0	14.88	415.0	16.34	273.0	10.75	70.0	2.76	85.0	3.35	422.5	16.63	70.0	2.76
16" 300	GP-100C-435A/C1D	2043.0	80.43	871.0	34.29	520.0	20.47	515.0	20.28	406.4	16.00	70.0	2.76	100.0	3.94	517.5	20.37	120.0	4.72
16" 600	GP-130C-585A/C1E	2304.0	90.71	1003.0	39.49	525.0	20.67	680.0	26.77	457.2	18.00	100.0	3.94	130.0	5.12	631.5	24.86	80.0	3.15
18" 150	GP-085C-385A/C2D	1595.5	62.81	672.5	26.48	381.0	15.00	465.0	18.31	273.0	10.75	70.0	2.76	85.0	3.35	447.5	17.62	80.0	3.15
18" 300	GP-130C-485A/C1D	2277.0	89.65	1003.0	39.49	525.0	20.67	570.0	22.44	457.2	18.00	100.0	3.94	130.0	5.12	576.5	22.70	115.0	4.53
18" 600	GP-161C-685A/C3D	3042.0	119.76	1523.0	59.96	612.0	24.09	780.0	30.71	609.6	24.00	100.0	3.94	160.0	6.30	790.0	31.10	110.0	4.33
20" 150	GP-100C-435A/C1D	2043.0	80.43	871.0	34.29	520.0	20.47	515.0	20.28	406.4	16.00	70.0	2.76	100.0	3.94	517.5	20.37	120.0	4.72
20" 300	GP-130C-535A/C2D	2304.0	90.71	1003.0	39.49	525.0	20.67	620.0	24.41	457.2	18.00	100.0	3.94	130.0	5.12	601.5	23.68	80.0	3.15
20" 600	GP-161S-685A/C3D	3042.0	119.76	1523.0	59.96	612.0	24.09	780.0	30.71	609.6	24.00	100.0	3.94	160.0	6.30	790.0	31.10	110.0	4.33
24" 150	GP-130C-485A/C1D	2277.0	89.65	1003.0	39.49	525.0	20.67	570.0	22.44	457.2	18.00	100.0	3.94	130.0	5.12	576.5	22.70	115.0	4.53
24" 300	GP-161C-585A/C2D	3202.0	126.06	1693.0	66.65	602.0	23.70	680.0	26.77	609.6	24.00	100.0	3.94	160.0	6.30	740.0	29.13	100.0	3.94
30" 150	GP-130C-685A/C2G	2332.0	91.81	1003.0	39.49	565.0	22.24	780.0	30.71	457.2	18.00	100.0	3.94	130.0	5.12	681.5	26.83	95.0	3.74
30" 300	GP-200C-785A/C2D	3388.0	133.39	1517.0	59.72	762.0	30.00	890.0	35.04	609.6	24.00	100.0	3.94	200.0	7.87	925.0	36.42	95.0	3.74
36" 150	GP-161C-785A/C3E	3078.0	121.18	1523.0	59.96	631.0	24.84	890.0	35.04	609.6	24.00	100.0	3.94	160.0	6.30	845.0	33.27	95.0	3.74
36" 300	GP-270S-945A/C4D	5124.0	201.73	2725.0	107.28	1001.0	39.41	1270.0	50.00	711.2	28.00	150.0	5.91	270.0	10.63	1215.0	47.83	135.0	5.31
42" 150	GP-161C-785A/C5D	3089.0	121.61	1534.0	60.39	631.0	24.84	890.0	35.04	609.6	24.00	100.0	3.94	160.0	6.30	845.0	33.27	95.0	3.74
42" 300	GP-201C-940A/C3D	4116.5	162.07	2113.0	83.19	811.5	31.95	1160.0	45.67	609.6	24.00	100.0	3.94	200.0	7.87	1060.0	41.73	120.0	4.72
48" 150	GP-200C-835A/C2D	3480.0	137.01	1517.0	59.72	771.0	30.35	940.0	37.01	609.6	24.00	100.0	3.94	200.0	7.87	950.0	37.40	140.0	5.51
48" 300	GP-270C-945A/C0E	5064.0	199.37	2665.0	104.92	1001.0	39.41	1270.0	50.00	711.2	28.00	150.0	5.91	270.0	10.63	1215.0	47.83	135.0	5.31

Actuator Data - GP Series Dimensions

Valve Size & Rating				Actuator Overall Dimensions												Total Weight																	
				Fail Close Actuator Model		K		ES		EC		ED		Standard			Cryogenic			LUG/WAFER			DFSP			DFLP							
						Standard	Cryogenic	mm	inch	mm	inch	mm	inch	mm	inch	LUG/WAFER	DFSP	DFLP	LUG/WAFER	DFSP	DFLP	LUG/WAFER	DFSP	DFLP	LUG/WAFER	DFSP	DFLP	Kg	Lbs	Kg	Lbs	Kg	Lbs
8" 600	GP-085S-335A/C4D	583.0	22.95	1072.6	42.23	305.0	12.01	146.7	5.77	225.8	8.89	434	956	1097	498	1097	459	1012	523	1153	565	1247	434	956	1097	498	1097	459	1012	523	1153	565	1247
10" 600	GP-100S-485A/C1D	491.0	19.33	1040.6	40.97	352.5	13.88	170.0	6.69	225.8	8.89	810	1787	1968	893	1968	838	1847	920	2028	1001	2207	810	1787	1968	893	1968	838	1847	920	2028	1001	2207
12" 600	GP-100S-535A/C2D	686.0	27.01	1246.2	49.06	352.5	13.88	170.0	6.69	290.8	11.45	900	1985	2202	999	2202	953	2100	1051	2318	1172	2583	900	1985	2202	999	2202	953	2100	1051	2318	1172	2583
14" 300	GP-085C-385A/C2D	503.0	19.80	1093.7	43.06	305.0	12.01	146.7	5.77	225.8	8.89	541	1192	1269	576	1269	568	1253	604	1331	712	1570	541	1192	1269	576	1269	568	1253	604	1331	712	1570
14" 600	GP-130C-535A/C1D	728.0	28.66	1375.2	54.14	424.0	16.69	204.0	8.03	290.8	11.45	1195	2635	2836	1286	2836	1252	2761	1343	2961	1508	3324	1195	2635	2836	1286	2836	1252	2761	1343	2961	1508	3324
16" 150	GP-085C-335A/C2D	493.0	19.41	1083.7	42.67	305.0	12.01	146.7	5.77	225.8	8.89	466	1027	1137	516	1137	494	1088	543	1198	569	1255	466	1027	1137	516	1137	494	1088	543	1198	569	1255
16" 300	GP-100C-435A/C1D	591.0	23.27	1194.8	47.04	352.5	13.88	170.0	6.69	290.8	11.45	871	1919	2034	923	2034	925	2039	977	2154	1116	2460	871	1919	2034	923	2034	925	2039	977	2154	1116	2460
16" 600	GP-130C-585A/C1E	648.5	25.53	1312.7	51.68	424.0	16.69	204.0	8.03	290.8	11.45	1375	3031	3309	1501	3309	1453	3203	1579	3481	1789	3945	1375	3031	3309	1501	3309	1453	3203	1579	3481	1789	3945
18" 150	GP-085C-385A/C2D	650.5	25.61	1282.1	50.47	305.0	12.01	146.7	5.77	225.8	8.89	555	1224	1369	621	1369	586	1292	652	1437	673	1483	555	1224	1369	621	1369	586	1292	652	1437	673	1483
18" 300	GP-130C-485A/C1D	656.5	25.85	1314.8	51.76	424.0	16.69	204.0	8.03	290.8	11.45	1249	2753	2838	1287	2838	1314	2896	1352	2981	1531	3376	1249	2753	2838	1287	2838	1314	2896	1352	2981	1531	3376
18" 600	GP-161C-685A/C3D	822.0	32.36	1561.2	61.46	530.0	20.87	253.3	9.97	290.8	11.45	2460	5423	5688	2580	5688	2610	5753	2730	6018	3068	6763	2460	5423	5688	2580	5688	2610	5753	2730	6018	3068	6763
20" 150	GP-100C-435A/C1D	642.5	25.30	1279.7	50.38	352.5	13.88	170.0	6.69	290.8	11.45	895	1974	2090	948	2090	953	2102	1006	2218	1045	2303	895	1974	2090	948	2090	953	2102	1006	2218	1045	2303
20" 300	GP-130C-535A/C2D	682.5	26.87	1377.3	54.22	424.0	16.69	204.0	8.03	290.8	11.45	1394	3072	3135	1422	3135	1457	3212	1485	3275	1731	3816	1394	3072	3135	1422	3135	1457	3212	1485	3275	1731	3816
20" 600	GP-161S-685A/C3D	857.0	33.74	1611.6	63.45	530.0	20.87	253.3	9.97	440.8	17.35	2609	5752	2741	6043	3161	6968	2779	6126	2911	6417	7342	2609	5752	2741	6043	3161	6968	2779	6126	2911	6417	7342
24" 150	GP-130C-485A/C1D	731.5	28.80	1388.7	54.67	424.0	16.69	204.0	8.03	290.8	11.45	1313	2895	3003	1362	3003	1375	3031	1423	3138	1495	3296	1313	2895	3003	1362	3003	1375	3031	1423	3138	1495	3296
24" 300	GP-161C-585A/C2D	792.0	31.18	1536.0	60.47	530.0	20.87	253.3	9.97	290.8	11.45	2396	5282	2432	2432	2432	2477	5461	2513	5541	2868	6322	2396	5282	2432	2432	2432	2477	5461	2513	5541	2868	6322
30" 150	GP-130C-685A/C2G	818.0	32.20			424.0	16.69	204.0	8.03	300.8	11.84	1941	4280	2005	4421	2184	4814						1941	4280	2005	4421	2184	4814					
30" 300	GP-200C-785A/C2D	978.5	38.52			662.5	26.08	316.7	12.47	440.8	17.35	3771	8314	3830	8443	4584	10105						3771	8314	3830	8443	4584	10105					
36" 150	GP-161C-785A/C3E	1040.0	40.94			530.0	20.87	253.3	9.97	440.8	17.35	3336	7356	3413	7524	3724	8209						3336	7356	3413	7524	3724	8209					
36" 300	GP-270S-945A/C4D	1090.0	42.91			800.0	31.50	386.7	15.22	500.8	19.72	7629	16819	7667	16903	8937	19703						7629	16819	7667	16903	8937	19703					
42" 150	GP-161C-785A/C5D	1140.0	44.88			530.0	20.87	253.3	9.97	500.8	19.72	4225	9315	4282	9440	4645	10239						4225	9315	4282	9440	4645	10239					
42" 300	GP-201C-940A/C3D	1178.0	46.38			662.5	26.08	316.7	12.47	530.8	20.90	6036	13307	6097	13442	8175	18022						6036	13307	6097	13442	8175	18022					
48" 150	GP-200C-835A/C2D	1285.0	50.59			662.5	26.08	316.7	12.47	552.8	21.76	5398	11901	5435	11981	5974	13170						5398	11901	5435	11981	5974	13170					
48" 300	GP-270C-945A/C0E	1312.0	51.65			800.0	31.50	386.7	15.22	580.8	22.87	8585	18926	8690	19158	11538	25436						8585	18926	8690	19158	11538	25436					

NA

NA

Actuator Data – GP Series Dimensions

Valve Size & Rating	Fail Open Actuator Model	Actuator Overall Dimensions																	
		A		B		C		ØD		ØE		F		G		H		J	
		mm	inch	mm	inch	mm	inch	mm	inch	mm	inch	mm	inch	mm	inch	mm	inch	mm	inch
10" 600	GP-085C-385A/O3D	1608.5	63.33	685.5	26.99	381.0	15.00	465.0	18.31	323.9	12.75	70.0	2.76	85.0	3.35	447.5	17.62	80.0	3.15
12" 600	GP-085S-485A/O3G	1618.5	63.72	685.5	26.99	391.0	15.39	570.0	22.44	323.9	12.75	70.0	2.76	85.0	3.35	500.0	19.69	80.0	3.15
14" 300	GP-085C-385A/O2D	1595.5	62.81	672.5	26.48	381.0	15.00	465.0	18.31	273.0	10.75	70.0	2.76	85.0	3.35	447.5	17.62	80.0	3.15
14" 600	GP-100S-535A/O2D	2033.0	80.04	829.0	32.64	525.0	20.67	620.0	24.41	406.4	16.00	70.0	2.76	100.0	3.94	570.0	22.44	80.0	3.15
16" 150	GP-085C-335A/O2D	1582.5	62.30	672.5	26.48	378.0	14.88	415.0	16.34	273.0	10.75	70.0	2.76	85.0	3.35	422.5	16.63	70.0	2.76
16" 300	GP-100C-485A/O1D	2048.0	80.63	871.0	34.29	525.0	20.67	570.0	22.44	406.4	16.00	70.0	2.76	100.0	3.94	545.0	21.46	115.0	4.53
16" 600	GP-130C-535A/O2D	2304.0	90.71	1003.0	39.49	525.0	20.67	620.0	24.41	457.2	18.00	100.0	3.94	130.0	5.12	601.5	23.68	80.0	3.15
18" 150	GP-085C-385A/O2D	1595.5	62.81	672.5	26.48	381.0	15.00	465.0	18.31	273.0	10.75	70.0	2.76	85.0	3.35	447.5	17.62	80.0	3.15
18" 300	GP-130C-485A/O1D	2277.0	89.65	1003.0	39.49	525.0	20.67	570.0	22.44	457.2	18.00	100.0	3.94	130.0	5.12	576.5	22.70	115.0	4.53
18" 600	GP-130S-685A/O5D	2338.0	92.05	1009.0	39.72	565.0	22.24	780.0	30.71	508.0	20.00	100.0	3.94	130.0	5.12	681.5	26.83	95.0	3.74
20" 150	GP-100C-485A/O1D	2048.0	80.63	871.0	34.29	525.0	20.67	570.0	22.44	406.4	16.00	70.0	2.76	100.0	3.94	545.0	21.46	115.0	4.53
20" 300	GP-130C-585A/O2D	2304.0	90.71	1003.0	39.49	525.0	20.67	680.0	26.77	457.2	18.00	100.0	3.94	130.0	5.12	631.5	24.86	80.0	3.15
20" 600	GP-161C-635A/O3D	3042.0	119.76	1523.0	59.96	612.0	24.09	730.0	28.74	609.6	24.00	100.0	3.94	160.0	6.30	765.0	30.12	110.0	4.33
24" 150	GP-130C-485A/O1D	2277.0	89.65	1003.0	39.49	525.0	20.67	570.0	22.44	457.2	18.00	100.0	3.94	130.0	5.12	576.5	22.70	115.0	4.53
24" 300	GP-161C-685A/O2D	3212.0	126.46	1693.0	66.65	612.0	24.09	780.0	30.71	609.6	24.00	100.0	3.94	160.0	6.30	790.0	31.10	110.0	4.33
30" 150	GP-130C-685A/O6D	2338.0	92.05	1009.0	39.72	565.0	22.24	780.0	30.71	508.0	20.00	100.0	3.94	130.0	5.12	681.5	26.83	95.0	3.74
30" 300	GP-200C-937A/O2D	3485.0	137.20	1517.0	59.72	776.0	30.55	1090.0	42.91	609.6	24.00	100.0	3.94	200.0	7.87	1025.0	40.35	135.0	5.31
36" 150	GP-161C-785A/O3G	3078.0	121.18	1523.0	59.96	631.0	24.84	890.0	35.04	609.6	24.00	100.0	3.94	160.0	6.30	845.0	33.27	95.0	3.74
36" 300	GP-201C-942A/O7E	4144.5	163.17	2141.0	84.29	811.5	31.95	1160.0	45.67	609.6	24.00	100.0	3.94	200.0	7.87	1060.0	41.73	120.0	4.72
42" 150	GP-161C-835A/O5E	3232.0	127.24	1534.0	60.39	686.0	27.01	940.0	37.01	609.6	24.00	100.0	3.94	160.0	6.30	870.0	34.25	140.0	5.51
42" 300	GP-201S-960A/O7G	4292.0	168.98	2141.0	84.29	959.0	37.76	1410.0	55.51	609.6	24.00	100.0	3.94	200.0	7.87	1185.0	46.65	135.0	5.31
48" 150	GP-200C-835A/O2D	3480.0	137.01	1517.0	59.72	771.0	30.35	940.0	37.01	609.6	24.00	100.0	3.94	200.0	7.87	950.0	37.40	140.0	5.51
48" 300	GP-270C-962A/O0E	5130.0	201.97	2665.0	104.92	1067.0	42.01	1355.0	53.35	711.2	28.00	150.0	5.91	270.0	10.63	1257.5	49.51	140.0	5.51

Actuator Data - GP Series Dimensions

Valve Size & Rating	Actuator Overall Dimensions											Total Weight											
	Fail Open Actuator Model		K		ES		EC		ED		Standard			Cryogenic									
			Standard	Cryogenic	mm	inch	mm	inch	mm	inch	mm	inch	LUGWAFER	DFSP	DFLP	LUGWAFER	DFSP	DFLP					
			mm	inch	mm	inch	mm	inch	mm	inch	mm	inch	Kg	Lbs	Kg	Lbs	Kg	Lbs	Kg	Lbs	Kg	Lbs	
10" 600	GP-085C-385A/O3D	478.0	18.82	1027.6	40.45	305.0	12.01	146.7	5.77	225.8	8.89	553	1220	636	1401	717	1580	581	1281	663	1462	744	1640
12" 600	GP-085S-485A/O3G	673.0	26.50	1233.2	48.55	305.0	12.01	146.7	5.77	290.8	11.45	730	1610	829	1827	949	2093	783	1725	881	1943	1002	2208
14" 300	GP-085C-385A/O2D	503.0	19.80	1093.7	43.06	305.0	12.01	146.7	5.77	225.8	8.89	541	1192	576	1269	684	1508	568	1253	604	1331	712	1570
14" 600	GP-100S-535A/O2D	708.0	27.87	1355.2	53.35	352.5	13.88	170.0	6.69	290.8	11.45	963	2124	1054	2324	1219	2687	1020	2249	1111	2450	1276	2813
16" 150	GP-085C-335A/O2D	493.0	19.41	1083.7	42.67	305.0	12.01	146.7	5.77	225.8	8.89	466	1027	516	1137	542	1195	494	1088	543	1198	569	1255
16" 300	GP-100C-485A/O1D	591.0	23.27	1194.8	47.04	352.5	13.88	170.0	6.69	290.8	11.45	934	2058	986	2173	1125	2479	988	2178	1040	2293	1179	2599
16" 600	GP-130C-535A/O2D	648.5	25.53	1312.7	51.68	424.0	16.69	204.0	8.03	290.8	11.45	1325	2920	1451	3199	1662	3663	1403	3092	1529	3371	1739	3835
18" 150	GP-085C-385A/O2D	650.5	25.61	1282.1	50.47	305.0	12.01	146.7	5.77	225.8	8.89	555	1224	621	1369	642	1414	586	1292	652	1437	673	1483
18" 300	GP-130C-485A/O1D	656.5	25.85	1314.8	51.76	424.0	16.69	204.0	8.03	290.8	11.45	1249	2753	1287	2838	1467	3233	1314	2896	1352	2981	1531	3376
18" 600	GP-130S-685A/O5D	785.0	30.91	1524.2	60.01	424.0	16.69	204.0	8.03	290.8	11.45	2052	4523	2172	4788	2510	5534	2202	4854	2322	5119	2660	5864
20" 150	GP-100C-485A/O1D	642.5	25.30	1279.7	50.38	352.5	13.88	170.0	6.69	290.8	11.45	958	2113	1011	2229	1050	2315	1016	2241	1069	2357	1108	2442
20" 300	GP-130C-585A/O2D	682.5	26.87	1377.3	54.22	424.0	16.69	204.0	8.03	290.8	11.45	1469	3238	1497	3300	1743	3842	1532	3377	1560	3440	1806	3982
20" 600	GP-161C-635A/O3D	857.0	33.74	1611.6	63.45	530.0	20.87	253.3	9.97	440.8	17.35	2527	5571	2659	5862	3079	6787	2697	5945	2829	6236	3248	7161
24" 150	GP-130C-485A/O1D	731.5	28.80	1388.7	54.67	424.0	16.69	204.0	8.03	290.8	11.45	1313	2895	1362	3003	1434	3160	1375	3031	1423	3138	1495	3296
24" 300	GP-161C-685A/O2D	792.0	31.18	1536.0	60.47	530.0	20.87	253.3	9.97	290.8	11.45	2579	5685	2615	5765	2970	6547	2660	5864	2696	5945	3051	6726
30" 150	GP-130C-685A/O6D	818.0	32.20			424.0	16.69	204.0	8.03	300.8	11.84	2201	4853	2265	4995	2444	5387						
30" 300	GP-200C-937A/O2D	978.5	38.52			662.5	26.08	316.7	12.47	440.8	17.35	4076	8986	4135	9115	4889	10777						
36" 150	GP-161C-785A/O3G	1040.0	40.94			530.0	20.87	253.3	9.97	440.8	17.35	3336	7356	3413	7524	3724	8209						
36" 300	GP-201C-942A/O7E	1073.0	42.24			662.5	26.08	316.7	12.47	500.8	19.72	6007	13243	6045	13327	7315	16127						
42" 150	GP-161C-835A/O5E	1140.0	44.88			530.0	20.87	253.3	9.97	500.8	19.72	4434	9776	4491	9901	4854	10700						
42" 300	GP-201S-960A/O7G	1178.0	46.38			662.5	26.08	316.7	12.47	530.8	20.90	7348	16199	7409	16334	9487	20914						
48" 150	GP-200C-835A/O2D	1285.0	50.59			662.5	26.08	316.7	12.47	552.8	21.76	5398	11901	5435	11981	5974	13170						
48" 300	GP-270C-962A/O0E	1312.0	51.65			800.0	31.50	386.7	15.22	580.8	22.87	9504	20952	9609	21184	12457	27462						

NA

NA



CONTROLS SUPPLY CHAIN

VALVES ACTUATORS INSTRUMENTATIONS