

Masoneilan™ 35002 Series Camflex™ II Rotary Control Valves

Complete line of eccentric plug control valves effectively combining enhanced control performance, simplicity and long-term reliability for a broad range of applications.



Table of contents

Features	1.....
Numbering System	2.....
Actuator Mounting Guide	3.....
General Data / Ratings and Connections	4-6
C_V and F_L Versus Travel	6-7..
C_V Versus Travel.....	8.....
Materials of Construction	9-13
Dimensions and Weights.....	14-15

Features

The Camflex II valve is a heavy-duty, automatic-throttling control valve that incorporates the following features:

- The flangeless body rating is a rugged ASME Class 600.
- Heavy-duty guide lugs assure quick, positive alignment during installation.
- The flanged version is available in 1 in. through 12 in. (25 mm through 300 mm) sizes in 150 or 300 ASME, and 1 in. through 8 in. (25 mm through 200 mm) in 600 ASME.
- The optional Camflex GR (Globe Replacement) version is available in 1 in through 6 in. sizes (25mm through 150mm) in ASME Class 150, 300, and 600 ratings and allows direct replacement of conventional reciprocating globe valves.
- Separable bonnet design is available.
- Straight through flow pattern provides greater flow capacities.
- Standard integral extension bonnet allows for a wide range of fluid temperature applications (-320°F to 750°F), (-196°C to 400°C).
- The unique self-aligning eccentric rotating plug provides tight shutoff and low dynamic forces.
- A large variety of reduced-trim options are available in all sizes.
- The triple, over-sized bearing system provides exceptional plug shaft guiding.
- The shouldered shaft design provides robust blowout prevention.
- An optional patented differential velocity device (DVD) separates compressible flowstreams into a high velocity core and a low velocity envelope flowstream. This provides up to 18 dBA noise attenuation.
- Optional alloy constructions are available.
- The powerful, low-profile, spring-diaphragm actuator guarantees positive fail-safe action.
- Splined shaft and actuator linkages, combined with low-friction techniques, contribute to reduced deadband and hysteresis.
- The valve position indicator is large and highly visible.
- The actuator linkage (purge option available) is totally enclosed).

Numbering system

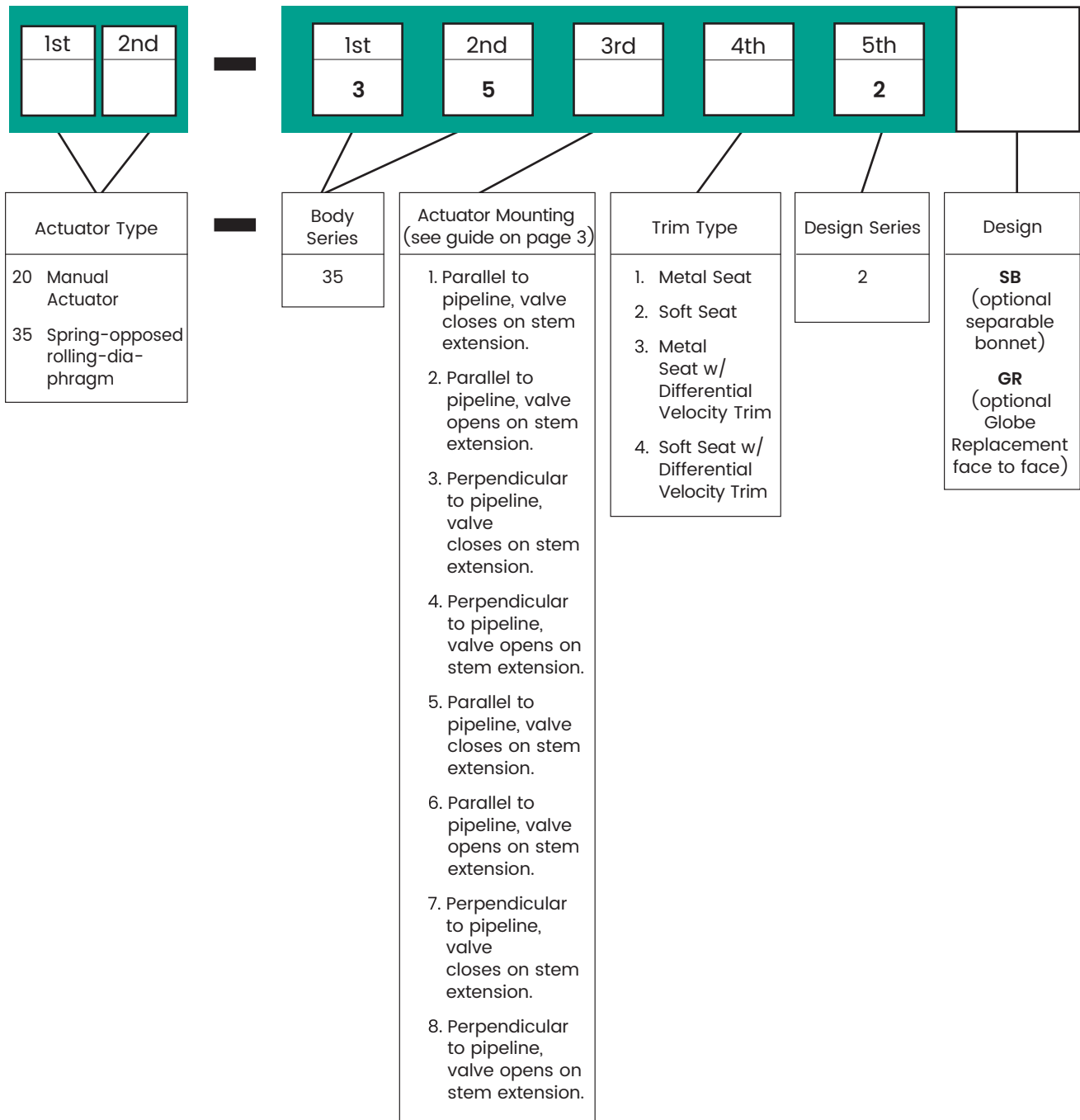

Actuator mounting guide

Camflex II Control Valves (Mounted on Horizontal Pipeline)

3 5 - 3 5 . 0 2

Actuator Position in Relation to Valve Body
Numbering System : 1 to 8

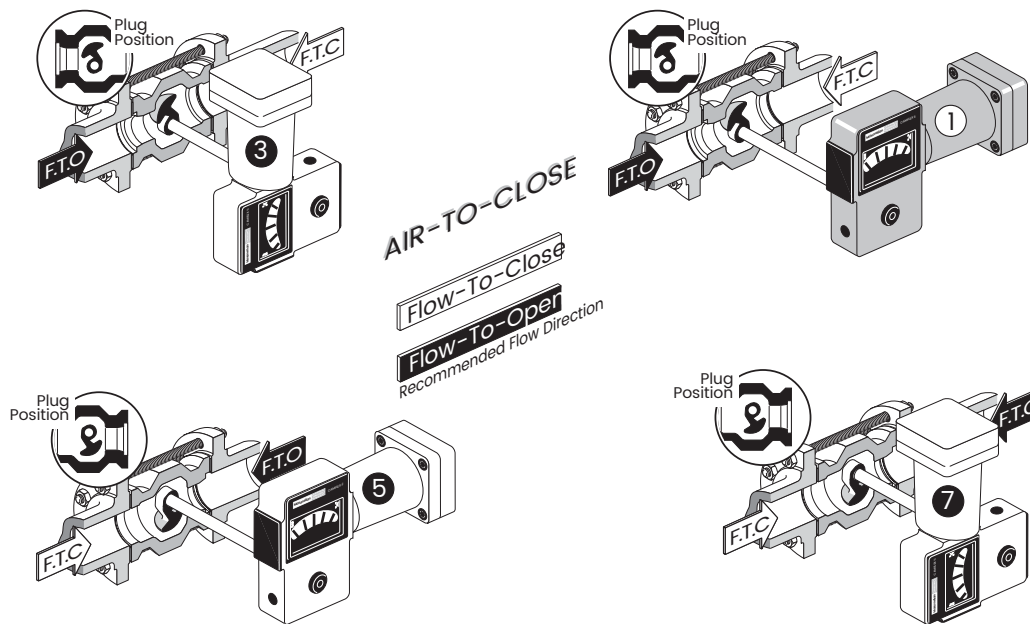
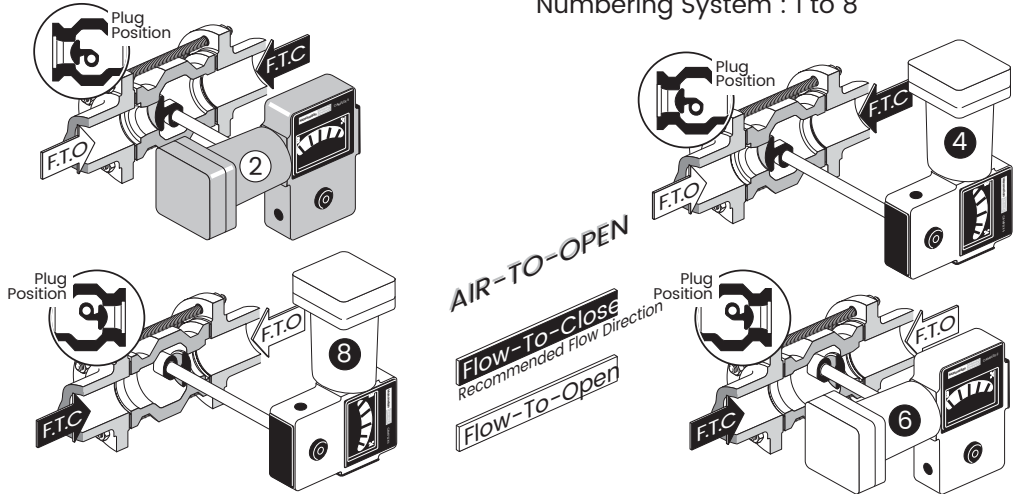

Notes

- Standard actuator mounting positions are shaded in grey.
- Plug positions are shown in the initial position without air on actuator.
- The actuator must be always mounted above the pipeline.
- It is recommended that the actuator always be mounted as shown above. For other positions, consult your local sales office.
- Installation is assumed to be in the horizontal pipeline for orientation of the airset and other accessories unless specified on the order.
- Action and orientation are field reversible without additional parts.
- Operating efficiencies may vary depending on valve configuration.
- The above schematic does not reflect every possible body/actuator orientation, but should serve as an effective guide.

General data

Body

Type:	<ul style="list-style-type: none"> cast with integral bonnet cast with separable bonnet – 1 in.-8 in.
Flow Direction:	flow to open or flow to close (Differential Velocity Device trim flow to open only)
Materials:	<ul style="list-style-type: none"> carbon steel 316 stainless steel (flangeless) 316L stainless steel (flanged) Hastelloy C (1 in.-4 in.) (DN 25-100)
Body Pressure Rating:	ASME Class 600 (per B16.34) standard (1 in.-12 in.) (DN 25-300), except for flanged construction: valve rating is limited by flange rating
End Connections:	<ul style="list-style-type: none"> threaded – NPT for ASME Class 600 rated connections (1 in.) (DN 25) flangeless – clamps between ASME Class 150, 300 or 600 rated flanges (flange rating must be specified for 8 in.-12 in. (DN 200-300) valve for locator lug drilling and tapping) flanged – bolts to ASME Class 150 or 300 rated flanges (1 in.-12 in.) (DN 25-300) ASME Class 600 rated flanges (1 in.- 8 in.) (DN 25-200) GR flanged – bolts to ASME Class 150, 300 or 600 rated flanges (1 in. - 6 in.) (DN 25-150)

Trim

Plug Type:	self-aligning eccentrically rotating
Materials:	<ul style="list-style-type: none"> 1 in.-2 in. (DN 25-100): solid Stellite No. 6 3 in.-4 in. (DN 80 & 100): solid Stellite No. 6 optional 3 in.-12 in. (DN 80-300): 316L stainless steel with hardfaced seating surface 1 in.-4 in. (DN 25-100): Hastelloy C
Seat Ring:	solid clamped
Materials:	<ul style="list-style-type: none"> 1 in.-12 in. (DN 25-300): 316 stainless steel 1 in.-4 in. (DN 25-100): Hastelloy C 1 in.-12 in. (DN 150-300): 316 stainless steel with hardfaced seat 1 in.-4 in. (DN 25-100): solid Stellite No. 6 optional 1 in.-12 in. (DN 25-300): 316 stainless steel with PTFE insert (to 450°F), (232°C)² 1 in.-12 in. (DN 25-300): 316 stainless steel with PCTFE insert (-50 to -320°F), (-46 to -196°C)²
Retainer:	316 Stainless Steel
Capacity:	full area and reduced capacity in all sizes
Flow Characteristic:	<ul style="list-style-type: none"> standard trim: linear low flow trim (.036 + .07 factor): linear (requires SVI) differential velocity device: linear
C _v Ratio:	<ul style="list-style-type: none"> standard trim >100:1 low flow trim 15:1 differential velocity device >50:1

Actuators

Spring-Opposed Rolling Diaphragm

Size:	<ul style="list-style-type: none"> 4½ in. diameter with ¾ in. (89mm) stroke (1 in.-2 in. valves), (DN 25-50) 6 in. diameter with 5¾ in. (146mm) stroke (3 in.-4 in. valves), (DN 80-100) 7 in. diameter with 7¼ in. (184mm) stroke (6 in.-12 in. valves), (DN 150-300) 9 in. diameter with 7¼ in. (184mm) stroke (6 in.-12 in. valves), (DN 150-300)
Range:	<ul style="list-style-type: none"> 7-15 psi (1 in.-4 in.), (DN 25-100) 7-24 psi (6 in.-12 in.), (DN 150-300) (7 in. diameter actuator) 7-24 psi (6 in.-12 in.), (DN 150-300) (9 in. diameter actuator, Air to Close) 8-25 psi (6 in.-12 in.), (DN 150-300) (9 in. diameter actuator, Air to Open)
Air Connection:	1/4 in. NPT
Yoke:	cast iron
Bearing:	sealed radial
Auxiliary Handwheel:	solid disk with locking nut: <ul style="list-style-type: none"> 6²/₅ in. diameter (1 in.-4 in. valves), (DN 25-100) 10 in. diameter (6 in.-12 in. valves), (DN 150-300)

Manual Actuator

Type:	Solid disk with detent anti-rotation device. Continuously connected.
Sizes:	<ul style="list-style-type: none"> 7 in. (178mm) diameter (1 in.-2 in. valves), (DN 25-50) 8⁷/₈ in. (225mm) diameter (3 in. & 4 in. valves), (DN 80-100) 16¹/₈ in. (410mm) diameter (6 in.-12 in. valves), (DN 150-300)
Material:	aluminum
Yoke:	cast iron
Bearing:	sealed radial ball

1. See materials of construction

2. Not available in .2 factor or Low Flow Trim sizes

General data

Standard Spring Diaphragm Actuator Materials

Description	Material
Yoke	Cast Iron
Yoke Covers	Polycarbonate
Spring Barrel	Die Cast Aluminum
Diaphragm Case	Die Cast Aluminum
Piston	Die Cast Aluminum
Diaphragm	Buna-N with Dacron Insert
Piston Rod	303 St. St.
Clevis	Carbon Steel Zinc Dichromate Plated
Clevis Pin	17-4 PH (H1075) St. St.
Lever	Steel With Epoxy Surface
Lever Bearing	PTFE Filament Surface Bonded to Glass Reinforced Plastic Backing
Handwheel and Locknut	Aluminum

Standard Actuator Characteristics and Travel Times

[Measured with direct positioner at 30 psi (2 bar) supply, 4700P positioner with tubing size ¼ in.]

Actuator Diameter		Diaphragm Effective Area		Actuator Stroke		Travel Time (sec.)	
in.	cm	sq. in.	cm ²	in.	cm	Increasing Instrument Signal	Decreasing Instrument Signal
4½	11.4	14	90	3½	8.9	1.2	2.4
6	15.2	24	155	5½	14.6	3	6.3
7	17.8	36	232	7½	18.4	7.6	9.8
9	22.9	75	483	7½	18.4	17	24

Temperature/Seat Leakage

Valve Size		Seat Type	Temp. Range ¹		Max. Seat Leakage, ASME FC1/70.2 Class
in.	DN		Min.	Max.	
1-12	25-300	Metal	-320°F (-196°C)	+750°F (400°C)	IV
		Soft Seat ²	-320°F (-196°C)	+450°F (232°C)	VI

1. For Stainless Steel Bodies only.

2. Temperature limited by PTFE/PCTFE seal.

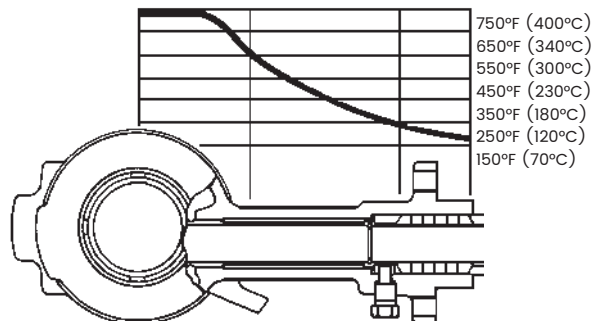

Temperature Gradient Across Standard Integral Bonnet

The ability of the Camflex valve to handle a wide range of process fluid temperatures is due to the long, integrally-cast bonnet. This affords ample radiation surface to normalize the packing temperatures.

Maximum Rated Flow Coefficients (C_v) and Critical Flow Factors (F_L) at Maximum Opening (50°)

Valve Size		Factor	Flow to Open		Flow to Close	
inches	DN		Rated C_v	F_L	Rated C_v	F_L
1	25	0.036	.5	0.98	.5	0.86
		0.07	1	0.98	1	0.86
		0.2	2.8	0.88	3	0.7
		0.4	5.6	0.88	6	0.7
		0.6	8.4	0.88	9	0.7
		1	14	0.85	15	0.68
1.5	40	DVD	5			
		0.4	13.2	0.88	15.6	0.7
		0.6	19.8	0.88	23.4	0.7
		1	33	0.85	39	0.68
2	50	DVD	12.5			
		0.4	20	0.88	21.2	0.7
		0.6	30	0.88	31.8	0.7
		1	50	0.85	53	0.68
3	80	DVD	18			
		0.4	54	0.88	58	0.7
		0.6	81	0.88	87	0.7
		1	135	0.85	145	0.68
4	100	DVD	48			
		0.4	92	0.88	92	0.7
		0.6	138	0.88	138	0.7
		1	230	0.85	230	0.68
6	150	DVD	78			
		0.4	200	0.88	200	0.7
		0.6	300	0.88	300	0.7
		1	500	0.85	500	0.68
8	200	DVD	181			
		0.4	340	0.88	340	0.7
		0.6	510	0.88	510	0.7
		1	850	0.85	850	0.68
10	250	DVD	308			
		0.4	520	0.88	520	0.7
		0.6	780	0.88	780	0.7
		1	1300	0.85	1300	0.68
12	300	DVD	486			
		0.4	700	0.88	700	0.7
		0.6	1050	0.88	1050	0.7
		1	1750	0.85	1750	0.68
12	300	DVD	684			

Note: Low flow trims (.036+.07 factor) require use of SVI IAP or SVI FF digital positioners.

Ratings and connections

Valve Size		ASME Class		
in.	DN	150	300	600
1-2	25-50	▲ ○ ● □	▲ ○ ● □	▲ ○ ● □
3-6	80-150	○ ● □	○ ● □	○ ● □
8	80-200	○ ●	○ ●	○ ●
10-12	250-300	○ ●	○ ●	○

Note: For flangeless valve sizes 8 in.-12 in., (200mm-300mm), please specify ASME Class rating.
Face to Face: ISA S75.04

▲ Threaded ○ Flangeless ● RF Flanged □ GR Flanged

C_V and F_L versus travel

Flow Direction: Flow to Open

Flow Characteristics: Linear

ASME Class: 150 through 600

Sizes: 1 in. through 12 in. (DN 25-300)

Percent of Plug Rotation						10	20	30	40	50	60	70	80	90	100
F _L Full Area						0.96	0.93	0.91	0.89	0.88	0.87	0.87	0.86	0.86	0.85
F _L Reduced Area (.6, .4, & .2)						0.96	0.93	0.91	0.89	0.88	0.88	0.88	0.88	0.88	0.88
Valve Size		Orifice Diameter		Travel		Rated C _V									
in.	DN	in.	mm	in.	mm										
1	25	.321	8.2	3.50	89	0.4	0.8	1.1	1.4	1.7	2.0	2.3	2.5	2.7	2.8
		.500	12.7	3.50	89	0.5	0.9	1.4	2.0	2.7	3.5	4.2	4.8	5.2	5.6
		.579	14.7	3.50	89	0.6	1.3	2.2	3.1	4.2	5.3	6.4	7.2	7.9	8.4
		.718	18.2	3.50	89	0.9	2.1	3.7	5.7	7.8	9.6	11.1	12.4	13.3	14
1 ½	40	.750	19.1	3.50	89	1.1	2.1	3.3	4.7	6.5	8.4	9.9	11.2	12.3	13.2
		.907	23.0	3.50	89	1.4	3.2	5.1	7.4	10.0	12.7	15.0	17.1	18.6	19.8
		1.125	28.6	3.50	89	2.0	5.0	8.6	13	19	22	26	29	32	33
2	50	1.000	25.4	3.50	89	1.6	3.2	5.0	7.2	9.8	12.6	15.0	17.0	18.7	20
		1.159	29.4	3.50	89	2.1	4.8	7.7	11.2	15.1	19.1	22.7	25.8	28.2	30
		1.437	36.5	3.50	89	3.1	7.5	13.3	20.5	28	34.2	39.8	44.2	47.5	50
3	80	1.500	38.1	5.75	146	4.9	9.4	14.1	20.0	26.5	33.5	39.8	45.4	50.2	54
		1.874	47.6	5.75	146	5.7	12.1	19.6	27.6	37.5	47.9	58.4	68.0	75.9	81
		2.324	59.0	5.75	146	8.8	17.7	29.8	44.5	60.7	78.3	96.2	113	127	135
4	100	2.000	50.8	5.75	146	8.4	16.1	24.0	34.1	45.1	57.1	67.8	77.4	85.6	92
		2.419	61.4	5.75	146	9.7	20.7	33.4	47.0	63.8	81.6	99.4	116	129	138
		3.000	76.2	5.75	146	15.0	30.2	50.8	75.8	104	133	164	193	216	230
6	150	3.000	76.2	7.25	184	18.2	34.9	52.2	74.1	98.0	124	147	168	186	200
		3.629	92.2	7.25	184	21.2	44.9	72.7	102	139	177	216	252	281	300
		4.500	114	7.25	184	32.7	65.7	110	165	225	290	356	419	470	500
8	200	3.797	96.4	7.25	184	22.0	44.2	71.9	107	150	196	241	283	317	340
		4.840	123	7.25	184	31.3	63.6	114	178	246	313	374	425	468	510
		6.000	152	7.25	184	42.8	111	201	316	434	542	639	725	798	850
10	250	4.746	121	7.25	184	33.7	67.6	110	164	230	300	369	432	485	520
		6.050	154	7.25	184	47.8	97.3	175	273	376	478	572	650	716	780
		7.500	191	7.25	184	65.5	170	307	483	663	828	977	1109	1221	1300
12	300	5.780	147	7.25	184	45.3	91.0	148	221	309	403	497	582	652	700
		7.460	189	7.25	184	64.4	131	235	367	506	644	769	875	964	1050
		9.250	235	7.25	184	88.1	228	414	650	893	1115	1315	1493	1644	1750

C_V and F_L versus travel

Flow Direction: Flow to Close

Flow Characteristics: Linear

ASME Class: 150 through 600

Sizes: 1 in. through 12 in. (DN 25-300)

Percent of Plug Rotation						10	20	30	40	50	60	70	80	90	100
F _L Full Area						0.94	0.91	0.88	0.83	0.80	0.77	0.74	0.72	0.70	0.68
F _L Reduced Area (.6, .4, & .2)						0.94	0.91	0.88	0.83	0.80	0.77	0.74	0.72	0.70	0.70
Valve Size		Orifice Diameter		Act. Stem Travel		Rated C _V									
in.	DN	in.	mm	in.	mm										
1	25	.321	8.2	3.50	89	0.4	0.9	1.2	1.5	1.8	2.1	2.5	2.7	2.9	3
		.500	12.7	3.50	89	0.5	1.0	1.5	2.1	2.9	3.8	4.5	5.1	5.6	6
		.579	14.7	3.50	89	0.6	1.4	2.4	3.3	4.5	5.7	6.9	7.7	8.5	9
		.718	18.2	3.50	89	1.0	2.3	4.0	6.1	8.4	10.3	11.9	13.3	14.3	15
1 ½	40	.750	19.1	3.50	89	1.3	2.5	3.9	5.6	7.7	9.9	11.7	13.2	14.5	15.6
		.907	23.0	3.50	89	1.7	3.8	6.0	8.7	11.8	15.0	17.7	20.2	22.0	23.4
		1.125	28.6	3.50	89	2.4	5.9	10.2	15.4	22.5	26.0	30.7	34.3	37.8	39
2	50	1.000	25.4	3.50	89	1.7	3.4	5.3	7.6	10.4	13.4	15.9	18.0	19.8	21.2
		1.159	29.4	3.50	89	2.2	5.1	8.2	11.9	16.0	20.2	24.1	27.3	29.9	31.8
		1.437	36.5	3.50	89	3.3	8.0	14.1	21.7	29.7	36.3	42.2	46.9	50.4	53
3	80	1.500	38.1	5.75	146	5.3	10.1	15.1	21.5	28.5	36.0	42.7	48.8	53.9	58
		1.874	47.6	5.75	146	6.1	13.0	21.1	29.6	40.3	51.4	62.7	73.0	81.5	87
		2.324	59.0	5.75	146	9.5	19.0	32.0	47.8	65.2	84.1	103	121	136	145
4	100	2.000	50.8	5.75	146	8.4	16.1	24.0	34.1	45.1	57.1	67.8	77.4	85.6	92
		2.419	61.4	5.75	146	9.7	20.7	33.4	47.0	63.8	81.6	99.4	116	129	138
		3.000	76.2	5.75	146	15.0	30.2	50.8	75.8	104	133	164	193	216	230
6	150	3.000	76.2	7.25	184	18.2	34.9	52.2	74.1	98.0	124	147	168	186	200
		3.629	92.2	7.25	184	21.2	44.9	72.7	102	139	177	216	252	281	300
		4.500	114	7.25	184	32.7	65.7	110	165	225	290	356	419	470	500
8	200	3.797	96.4	7.25	184	22.0	44.2	71.9	107	150	196	241	283	317	340
		4.840	123	7.25	184	31.3	63.6	114	178	246	313	374	425	468	510
		6.000	152	7.25	184	42.8	111	201	316	434	542	639	725	798	850
10	250	4.746	121	7.25	184	33.7	67.6	110	164	230	300	369	432	485	520
		6.050	154	7.25	184	47.8	97.3	175	273	376	478	572	650	716	780
		7.500	191	7.25	184	65.5	170	307	483	663	828	977	1109	1221	1300
12	300	5.780	147	7.25	184	45.3	91.0	148	221	309	403	497	582	652	700
		7.460	189	7.25	184	64.4	131	235	367	506	644	769	875	964	1050
		9.250	235	7.25	184	88.1	228	414	650	893	1115	1315	1493	1644	1750

C_v versus travel

Differential Velocity Device (DVD)

Flow Direction: Flow to Open only

Flow Characteristics: Linear

ASME Class: 150 through 600

Sizes: 1 in. through 12 in. (DN 25-300)

Percent of Plug Rotation						10	20	30	40	50	60	70	80	90	100	
Valve Size		Orifice Diameter		Travel		Rated C _v										
in.	DN	in.	mm	in.	mm											
1	25	0.579	14.7	3.5	89	0.52	1.04	1.88	2.62	3.23	3.76	4.22	4.58	4.84	5.00	
1½	40	0.907	23.0	3.5	89	1.30	2.60	4.69	6.54	8.06	9.41	10.5	11.4	12.1	12.5	
2	50	1.159	29.4	3.5	89	1.88	3.75	6.75	9.42	11.6	13.6	15.2	16.5	17.4	18.0	
3	80	1.874	47.6	5.75	146	5.00	10.0	18.0	25.1	31.0	36.1	40.5	43.9	46.4	48.0	
4	100	2.419	61.4	5.75	146	8.13	16.3	29.3	40.8	50.3	58.7	65.8	71.4	75.4	77.0	
6	150	3.629	92.2	7.25	184	18.9	37.7	67.9	94.7	116	136	153	166	175	181	
8	200	4.84	123	7.25	184	32.1	64.2	116	161	199	232	260	282	298	308	
10	250	6.05	154	7.25	184	50.6	101	182	254	313	366	410	445	470	486	
12	300	7.46	189	7.25	184	71.3	143	257	358	441	515	577	626	661	684	

Note: The differential velocity device is used for aerodynamic noise reduction. It **must** be used with **.6 factor trim flow to open**.

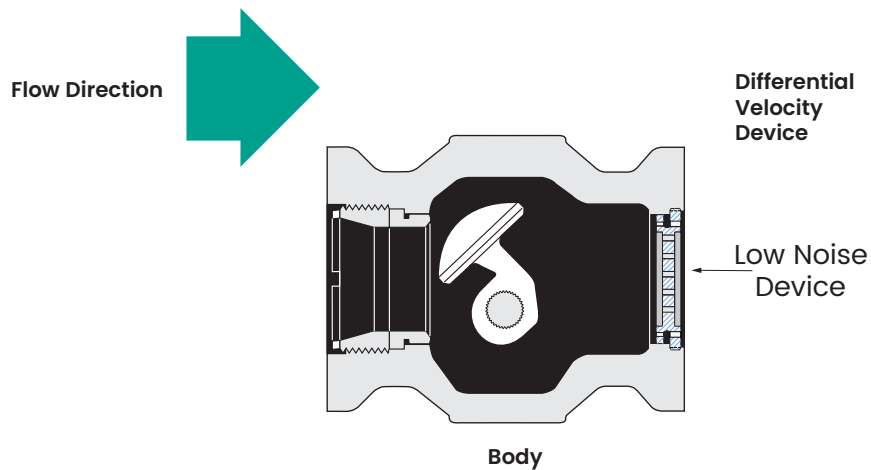

Materials of construction

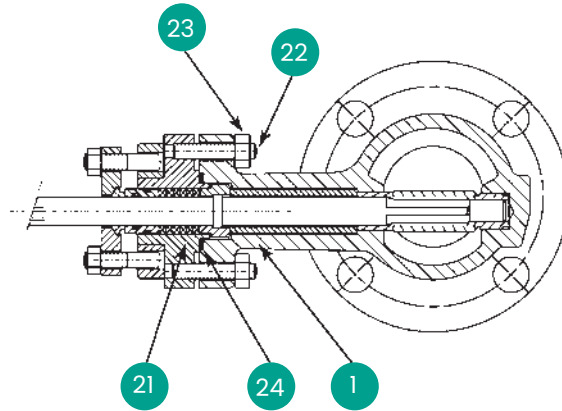

Body with Separable Bonnet

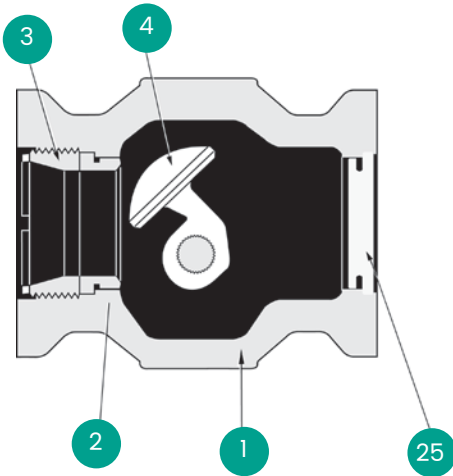

Body

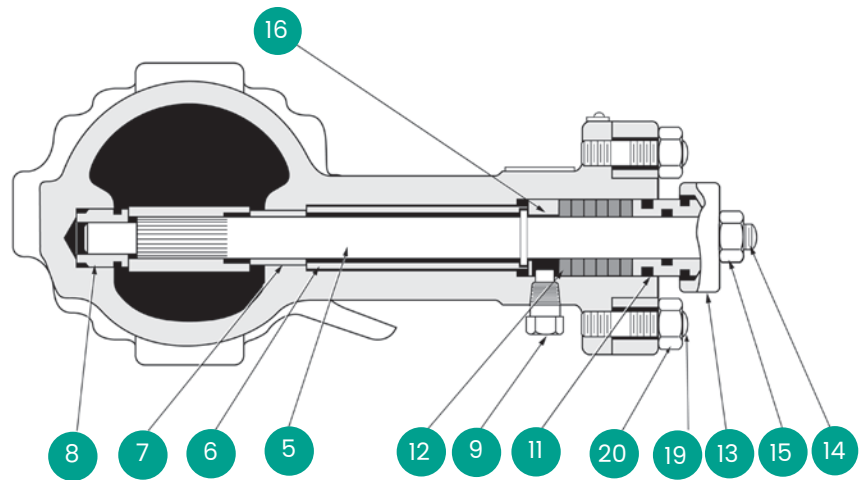

Body with Integral Bonnet

Optional Slurry Package Seal Bushings

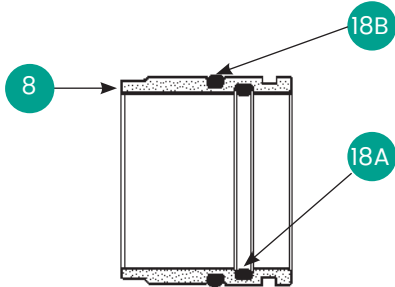

Lower Guide Bushing

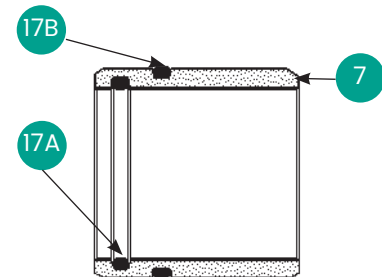

Upper Guide Bushing

Standard Camflex Packing Arrangement EF Seal (Emission Free) Double O-Ring Seal Packing Follower Fugitive Emission Containment Package for Zero Leakage¹

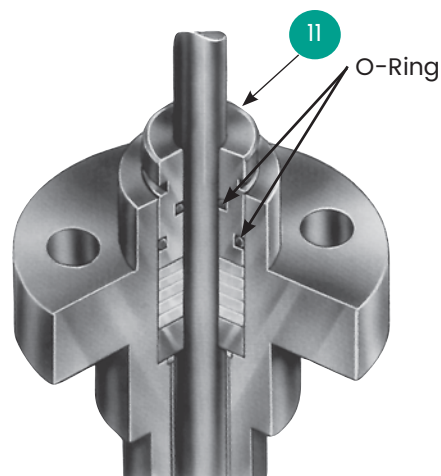

Provides long term reliable extremely low emission shaft seal performance. This economical solution to fugitive emissions will not compromise control performance, and is suitable for use in environmentally sensitive applications.

¹ Factory Mutual Certified Report

Materials of construction

Carbon Steel Construction

Ref. No.	Temperature Range	-20°F (-29°C)	+400°F (+205°C)	+450°F (+232°C)	+750°F (+400°C)
	Description	Materials			
1	Body	A216 Gr WCC			
2	Seat Ring	316 St. St. ASTM A351 Gr CF8M			
		316 St. St. ASTM A351 Gr CF8M + Stellite Hardfacing Optional			
3	Seat Ring Retainer	ASTM A479 TY 316 St. St. + PTFE 1 in. to 6 in. (DN 25-150) 316 St. St. A351 Gr CF8M + PTFE 8 in. to 12 in. (DN 200-300)			
4	Plug	316 St. St. ASTM A351 Gr CF8M			
5	Shaft	Solid Stellite 1 in. to 2 in. (DN 25-50) 316L St. St. ASTM A351 Gr CF3M + Stellite Hardfacing 3 in. to 12 in. (DN 80-300)			
6	Spacer	17-4 PH ASTM A564 Gr 630 (H1075)			
7	Upper Guide	ASTM A312 TY 316			
8	Upper Guide + O-Ring	ASTM A276 TY 440C			
	Lower Guide	STELLITE No. 6 + VITON			
9	Lower Guide + O-Ring	ASTM A276 TY 440C			
	Safety Pin	STELLITE No. 6 + VITON			
11	Packing Follower	ASTM A479 TY 316			
	O-Ring Packing Follower	VITON			
12	Packing	CARBON CORE BRAIDED PTFE			
13	Packing Flange	Carbon Steel ASTM A105 Zinc Plated			
14	Packing Flange Stud	304 St. St. ASTM A193 Gr B8			
15	Packing Flange Stud Nut	304 St. St. ASTM A194 GR 8			
16	Packing Box Ring	ASTM A479 TY 316			
19	Body Stud	304 St. St. ASTM A193 Gr B8			
20	Body Stud Nuts	304 St. St. ASTM A194 Gr 8			
21 ¹	Bonnet	Carbon Steel A216 GR WCC			
22 ¹	Body / Bonnet Stud	ASTM A 193 Gr B8 Class 2			
23 ¹	Body / Bonnet Nut	ASTM A 194 Gr 8			
24 ¹	Body Gasket	AISI 316L + GRAPHITE			
25	DVD Low Noise Plate	ASTM A479 TY 316			

1. Separable Bonnet version only.

NACE Carbon Steel Construction

Ref. No.	Temperature Range	-20°F (-29°C)	+400°F (+205°C)	+450°F (+232°C)	+750°F (+400°C)
	Description	Materials			
1	Body	Carbon Steel A216 Gr WCC			
2	Seat Ring	316 St. St. ASTM A351 Gr CF8M			
		316 St. St. ASTM A351 Gr CF8M + Stellite Hardfacing Optional			
3	Seat Ring Retainer	316 St. St. ASTM A351 Gr CF8M			
4	Plug	Solid Stellite 1 in. to 2 in. (DN 25-50) 316L St. St. ASTM A351 Gr CF3M + Stellite Hardfacing 3 in. to 12 in. (DN 80-300)			
5	Shaft	ASTM A479 TY 316 St. St.			
6	Spacer	ASTM A312 TY 316			
7	Upper Guide	STELLITE No. 6			
	Upper Guide + O-Ring	STELLITE No. 6 + VITON			
8	Lower Guide	STELLITE No. 6			
	Lower Guide + O-Ring	STELLITE No. 6 + VITON			
9	Safety Pin	ASTM A479 TY 316			
11	Packing Follower	ASTM A479 TY 316			
	O-Ring Packing Follower	VITON			
12	Packing	CARBON CORE BRAIDED PTFE			
13	Packing Flange	Carbon Steel ASTM A105 Zinc Plated			
14	Packing Flange Stud	304 St. St. ASTM A 193 GR B8			
15	Packing Flange Stud Nut	304 St. St. ASTM A194 GR 8			
16	Packing Box Ring	ASTM A479 TY 316			
19	Body Stud	304 St. St. ASTM A193 Gr B8			
20	Body Stud Nuts	304 St. St. ASTM A194 Gr 8			
25	DVD Low Noise Plate	ASTM A479 TY 316			

Note: Standard materials and processes are in accordance with the requirements of NACE specification MR0103. Applications requiring compliance to MR0175-2003 or ISO 15156 must be reviewed by Baker Hughes.

Materials of construction

Stainless Steel Construction

Ref. No.	Temperature Range	-320°F (-196°C)	-58°F (-50°C)	-50°F (-46°C)	+400°F (+205°C)	+450°F (+232°C)	+750°F (+400°C)	
		Materials						
1	Body	Flangeless Body 316 St. St. ASTM A351 Gr CF8M Flanged Body 316L St. St. ASTM A351 GR CF3M						
2	Seat Ring	316 St. St. ASTM A351 Gr CF8M 316 St. St. ASTM A351 Gr CF8M + Stellite Hardfacing Optional ASTM A479 TY 316 St. St. + PCTFE 1 in. to 6 in. (DN 25-150) ASTM A479 TY 316 St. St. + PTFE 1 in. to 6 in. (DN 25-150) 316 St. St. A351 Gr CF8M + PCTFE 8 in. to 12 in. (DN 200-300) 316 St. St. A351 Gr CF8M + PTFE 8 in. to 12 in. (DN 200-300)						
3	Seat Ring Retainer	316 St. St. ASTM A351 Gr CF8M						
4	Plug	Solid Stellite 1 in. to 2 in. (DN 25-50) 316L St. St. ASTM A351 Gr CF3M + Stellite Hardfacing N°6 3 in. to 12 in. (DN 80-300)						
5	Shaft	316 St. St. ASTM A479 TY 316 ASTM A564 Gr 630 (H1075) Optional						
6	Spacer	ASTM A 312 TY 316						
7	Upper Guide	STELLITE No. 6						
	Upper Guide + O-Ring	STELLITE No. 6 + VITON						
8	Lower Guide	STELLITE No. 6						
	Lower Guide + O-Ring	STELLITE No. 6 + VITON						
9	Safety Pin	ASTM A479 TY 316						
11	Packing Follower	ASTM A479 TY 316						
	O-Ring	VITON						
12	Packing	CARBON CORE BRAIDED PTFE						
13	Packing Flange	ASTM A182 GR F304						
14	Packing Flange Stud	304 St. St. ASTM A193 Gr B8						
15	Packing Flange Stud Nut	304 St. St. ASTM A194 Gr 8						
16	Packing Box Ring	ASTM A479 TY 316						
19	Body Stud	304 St. St. ASTM A 193 Gr B8						
20	Body Stud Nuts	304 St. St. ASTM A194 Gr 8						
21 ¹	Bonnet	316L St. St. ASTM A351 Gr CF3M						
22 ¹	Body / Bonnet Stud	304 St. St. ASTM A193 GR B8 CL 2						
23 ¹	Body / Bonnet Nut	304 St. St. ASTM A194 GR 8						
24 ¹	Body Gasket	AISI 316L + GRAPHITE						
25	DVD Low Noise Plate	ASTM A479 TY 316						

1. Separable Bonnet version only.

Materials of construction

NACE Stainless Steel Construction

Ref. No.	Temperature Range	-20°F (-29°C)	+400°F +205°C	+750°F (+400°C)
	Description	Materials		
1	Body	Flangeless Body 316 St. St. ASTM A351 Gr CF8M Flanged Body 316L St. St. ASTM A351 Gr CF3M		
2	Seat Ring	316 St. St. ASTM A351 Gr CF8M 316 St. St. ASTM A351 Gr CF8M + Stellite Hardfacing		
3	Seat Ring Retainer	316 St. St. ASTM A351 Gr CF8M		
4	Plug	Solid Stellite 1 in. to 2 in. (DN 25-50) 316L St. St. ASTM A351 Gr CF3M + Stellite Hardfacing 3 in. to 12 in. (DN 80-300)		
5	Shaft	ASTM A479 TY 316 St. St.		
6	Spacer	ASTM A312 TY 316		
7	Upper Guide	STELLITE No. 6		
	Upper Guide + O-Ring	STELLITE No. 6 + VITON		
8	Lower Guide	STELLITE No. 6		
	Lower Guide + O-Ring	STELLITE No. 6 + VITON		
9	Safety Pin	ASTM A479 TY 316		
11	Packing Follower	ASTM A479 TY 316		
	O-Ring Packing Follower	VITON		
12	Packing	CARBON CORE BRAIDED PTFE		
13	Packing Flange	ASTM A182 GR F304		
14	Packing Flange Stud	304 St. St. ASTM A193 Gr B8		
15	Packing Flange Stud Nut	304 St. St. ASTM A194 Gr 8		
16	Packing Box Ring	ASTM A479 TY 316		
19	Body Stud	304 St. St. ASTM A 193 Gr B8		
20	Body Stud Nuts	304 St. St. ASTM A194 Gr 8		
25	DVD Low Noise Plate	ASTM A479 TY 316		

Note: Standard materials and processes are in accordance with the requirements of NACE specification MR0103. Applications requiring compliance to MR0175-2003 or ISO 15156 must be reviewed by Baker Hughes.

Materials of construction

Hastelloy C Construction 1 in to 4 in

Ref. No.	Temperature Range	-320°F (-196°C)	-58°F (-50°C)	-50°F (-46°C)	+400°F (+205°C)	+450°F (+232°C)	+750°F (+400°C)	
		Materials						
1	Body	ASTM A494 Gr CX-2 MW						
2	Seat Ring	HASTELLOY C22 + PCTFE			HASTELLOY C22			
						HASTELLOY C22 + PTFE		
3	Seat Ring Retainer	HASTELLOY C22						
4	Plug	HASTELLOY C22						
5	Shaft	HASTELLOY C22						
6	Spacer	HASTELLOY C22						
7	Upper Guide ¹	STELLITE No. 6						
	Upper Guide ¹	ALLOY 25						
	Upper Guide ¹	ULTIMET						
	Upper Guide + O-Ring				STELLITE No. 6 + VITON			
8	Lower Guide ¹	STELLITE No. 6						
	Lower Guide ¹	ALLOY 25						
	Lower Guide ¹	ULTIMET						
	Lower Guide + O-Ring				STELLITE No. 6 + VITON			
9	Safety Pin	HASTELLOY C22						
11	Packing Follower	HASTELLOY C22						
	O-Ring	VITON						
12	Packing	CARBON CORE BRAIDED PTFE						
13	Packing Flange	ASTM A182 Gr F304						
14	Packing Flange Stud	304 St. St. ASTM A193 Gr B8						
15	Packing Flange Stud Nut	304 St. St. ASTM A194 Gr 8						
16	Packing Box Ring	HASTELLOY C22						
19	Body Stud	304 St. St. ASTM A193 Gr B8						
20	Body Stud Nuts	304 St. St. ASTM A194 Gr 8						
25	DVD Low Noise Plate	HASTELLOY C22						

Note: Standard materials and processes are in accordance with the requirements of NACE specification MR0103. Applications requiring compliance to MR0175-2003 or ISO 15156 must be reviewed by Baker Hughes.

1. Material selection must be based on fluid properties and compatibility.

Dimensions and weights

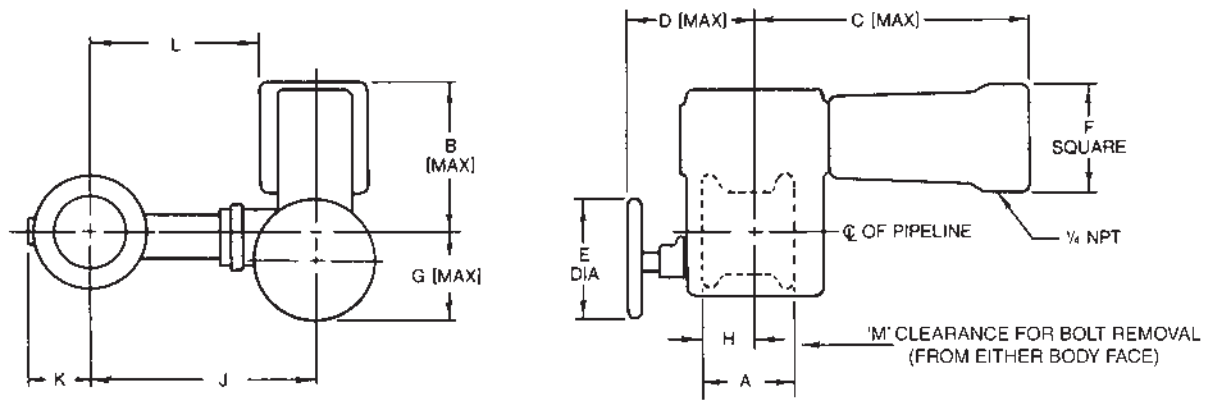

Dimensions (inches)

Valve Size		A					B	C	D	E	F	G	H					J	K	L	M			
In.	DN	Threaded ends	Flanged and Flange-less	GR Flanged Class 150	GR Flanged Class 300	GR Flanged Class 600							Threaded ends	Flange-less	Flanged	GR Flanged Class 150	GR Flanged Class 300				GR Flanged Class 600	ASME Class 150 PN 10	ASME Class 300 PN 16	ASME Class 600 PN 40
1	25	4.00	4.00	7.24	7.76	8.27	6.6	11.9	10.1	6.3	5.5	4.3	2.64	2.64	2.01	5.24	5.49	6.10	8.0	1.5	5.3	6.5	9.0	9.0
1/2	40	5.39	4.50	8.74	9.25	9.88	6.6	11.9	10.1	6.3	5.5	4.3	3.31	2.44	2.31	6.71	6.99	7.62	9.1	2.0	6.4	6.5	10.0	10.0
2	50	5.75	4.88	10.00	10.51	11.26	6.6	11.9	10.1	6.3	5.5	4.3	3.31	2.44	2.46	7.80	8.05	8.80	9.3	2.6	6.6	10.5	10.5	10.5
3	80		6.50	11.73	12.52	13.27	9.8	17.2	10.6	6.3	6.9	5.8		3.82	3.39	8.97	9.36	10.11	12.9	3.3	9.4	11.8	13.5	14.0
4	100		7.62	13.86	14.49	15.51	9.8	17.2	10.3	6.3	6.9	4.8		4.17	4.17	6.93	7.24	7.76	13.7	4.3	10.3	13.0	14.0	16.5
6	150		9.00	17.76	18.62	20.00	12.3	20.8	12.1	10.0	8.6	7.9		5.00	5.00	8.88	9.31	10.00	16.9	5.8	12.6	15.5	16.0	18.5
8	200		9.56				12.3	20.8	12.1	10.0	8.6	7.9		5.83	5.44				18.4	8.0	14.1	15.5	18.5	21.0
10	250		11.69				12.3	20.8	12.1	10.0	8.6	7.9		6.57	6.57				22.4	9.8	18.1	20.0	20.5	24.5
12	300		13.31				12.3	20.8	12.1	10.0	8.6	7.9		7.24	7.24				23.8	10.8	19.5	20.0	22.5	25.5

Weight (Kg and Lbs.)

Valve Size		Actuator size	Flangeless		Flanged Class 150		Flanged Class 300		Flanged Class 600		GR Flanged Class 150		GR Flanged Class 300		GR Flanged Class 600	
In.	DN		Kg	lbs.	Kg	lbs.	Kg	lbs.	Kg	lbs.	Kg	lbs.	Kg	lbs.	Kg	lbs.
1	25	4.5	17	38	18	40	20	44	20	44	19	42	21	46	22	49
1-1/2	40	4.5	19	42	22	48	24	53	25	55	23	51	26	57	28	62
2	50	4.5	20	44	24	53	27	60	28	62	27	60	30	66	34	75
3	8	6	46	101	52	115	57	126	59	130	58	128	63	139	69	152
4	100	6	54	119	65	143	73	161	83	183	74	163	83	183	99	218
6	150	7	103	227	115	254	131	289	156	344	133	293	151	333	184	406
		9	131	289	143	315	159	351	184	414	161	355	179	395	213	414
8	200	7	122	269	140	309	161	355	197	434						
		9	150	331	168	370	189	417	225	195						
10	250	7	178	392	203	448	236	520								
		9	206	454	231	509	264	582								
12	300	7	222	489	260	573	307	676								
		9	250	551	288	635	335	738								

Specific Dimensions (inches) for the No. 9 Actuator

Valve size		B	C	D	E	F	G	L
In.	DN							
6	150	14.69	26.54	12.05	15.75	11.97	8.39	11.02
8	200	14.80	26.54	12.05	15.75	11.97	8.50	12.52
10	250	14.92	26.54	12.05	15.75	11.97	8.62	16.61
12	300	15.04	26.54	12.05	15.75	11.97	8.74	17.99

Dimensions and weights

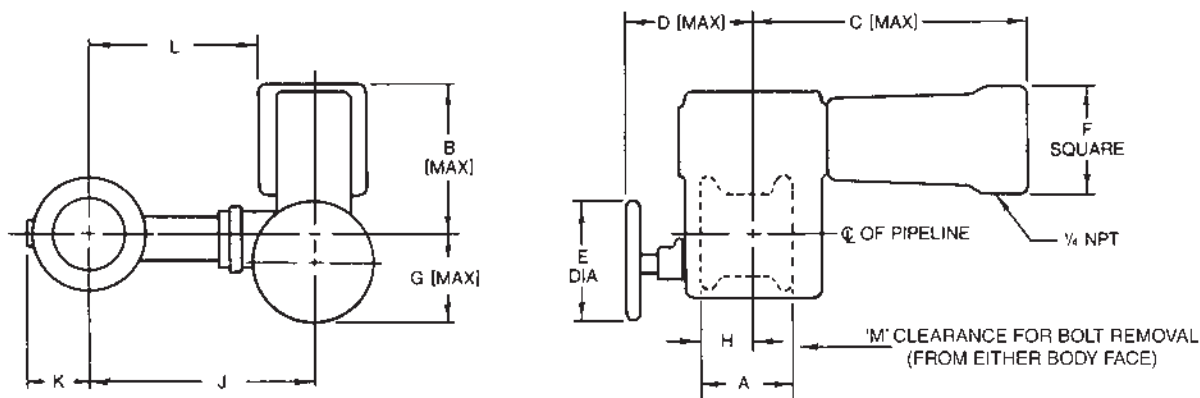

Dimensions (millimeters)

Valve Size		A					B	C	D	E	F	G	H					J	K	L	M			
In.	DN	Threaded ends	Flanged and Flange-less	GR Flanged Class 150	GR Flanged Class 300	GR Flanged Class 600							Threaded ends	Flange-less	Flanged	GR Flanged Class 150	GR Flanged Class 300				GR Flanged Class 600	ASME Class 150 PN 10	ASME Class 300 PN 16	ASME Class 600 PN 40
1	25	102	102	184	197	210	168	302	256	140	140	109	67	67	51	133	140	155	204	38	134	205	229	229
1/2	40	137	114	222	235	251	168	302	256	140	140	109	84	62	59	171	178	194	232	51	162	205	254	254
2	50	146	124	254	267	286	168	302	256	140	140	109	84	62	63	198	205	224	237	65	167	267	267	267
3	80		165	298	318	337	249	436	269	175	175	122		97	86	228	238	257	327	84	239	300	343	343
4	100		194	352	368	394	249	436	269	175	175	122		106	106	176	184	197	349	108	262	330	343	406
6	150		229	451	473	508	313	527	307	219	219	200		127	127	226	237	254	429	146	320	394	470	470
8	200		243				313	527	307	219	219	200		148	138				467	203	358	394	470	533
10	250		297				313	527	307	219	219	200		167	167				569	250	460	460	530	595
12	300		338				313	527	307	219	219	200		184	184				604	275	495	505	575	648

Specific Dimensions (millimeters) for the No. 9 Actuator

Valve size		B	C	D	E	F	G	L
In.	DN							
6	150	373	674	306	400	304	213	280
8	200	376	674	306	400	304	216	318
10	250	379	674	306	400	304	219	422
12	300	382	674	306	400	304	222	457



CONTROLS SUPPLY CHAIN

VALVES ACTUATORS INSTRUMENTATIONS