

Masoneilan™ 39004 Series

High Performance
Butterfly Valves



Table of Contents

Overview	3
Features	3
Features - Seat Design	4
Features - Actuator.....	5
Numbering System	6
General Data	7
Pressure/Temperature Ratings	8
Body Assembly Data	9
Actuator Data.....	9
Rated Flow Coefficients (C_v).....	10
Pressure Recovery Coefficients (F_L).....	11
Materials of Construction	12
Weights and Dimensions	14
Options and Accessories.....	24
Sales Offices.....	Back Cover

Overview

Masoneilan 39004 Series High Performance Butterfly Valve (HPBV) is designed for exceptional performance, application flexibility and long service life. This automatic throttling control valve offers benefits such as enhanced sealing, double offset operation, excellent flow characteristics, accurate positioning, and dynamic operation. The 39004 Series features seal designs for soft seal and fire-safe configurations. Combined with the Masoneilan 96/97 Series actuator, the 39004 Series High Performance Butterfly Valve package delivers years of dependable performance in demanding applications.

Features

The 39004 Series High Performance Butterfly Valve incorporates two main features that differentiate it from conventional swing-through butterfly valves – a seal ring and double offset (eccentric) operating principles for the seal and the shaft.

The use of a seal ring eliminates the inherent problem of high sealing forces due to interference fit and the resultant high wear rates caused by liner scraping and scuffing. Additionally, the dynamic, pressure-assisted seal design results in ASME Class VI shutoff rates available throughout the full range of ASME Class 150, 300 and 600 ratings.

The double offset (eccentric) operating principles shown in Figure 1, apply to both the seal offset, in which the seal ring centerline is offset from the shaft centerline, and shaft offset in which the shaft centerline is offset from the valve centerline. The design allows the disc to lift from the seal quickly due to the camming rotation with respect to the valve/seal centerlines.

These two features contribute to an exceptional high performance butterfly valve that offers many benefits:

Long Seal Life

The double offset operation lifts the disc from the seal quickly to minimize sliding contact and friction. The result is reduced seal wear as well as lower breakaway and seating torque requirements. This design has been extensively tested maintaining zero leakage shutoff performance throughout the entire life-cycle endurance test.

Fast and Dynamic Operation

Double offset operation eliminates disc-to-seal friction throughout the operating range resulting in fast response to input signals. Also, the disc tends to move in the direction of flow which enables the valve and actuator to maximize allowable operating pressures.

Ease of Installation and Maintenance

The reduced size and weight of the 39004 Series valve compared to typical rotary and globe products enables fast and easy installation into the pipeline. The seat design also supports easy maintenance by allowing the removal and replacement of the seat retainer without modifying the disc or stem.

Excellent Flow Characteristics

The offset disc design provides an approximate equal percentage flow characteristic through its full travel of 90° rotation yielding a C_v ratio of 100:1.

Precise Positioning

Extra heavy shafts with keyed ends for actuator mounting offer accurate positioning without lost motion or backlash.

Cost Savings

The design of the 39004 Series reduces operating torques. As a result, smaller actuation packages are required to operate the valve. Maintenance costs are also reduced through the modular seal design.

Long Service Life

The PTFE-lined low-friction bearings provide excellent service life while resisting corrosion and distortion from high temperatures and mechanical loading.

Application Flexibility

The Masoneilan 39004 Series is suited for a wide range of control applications including corrosive chemicals, water, gases, acids, hydrocarbons and other process fluids.

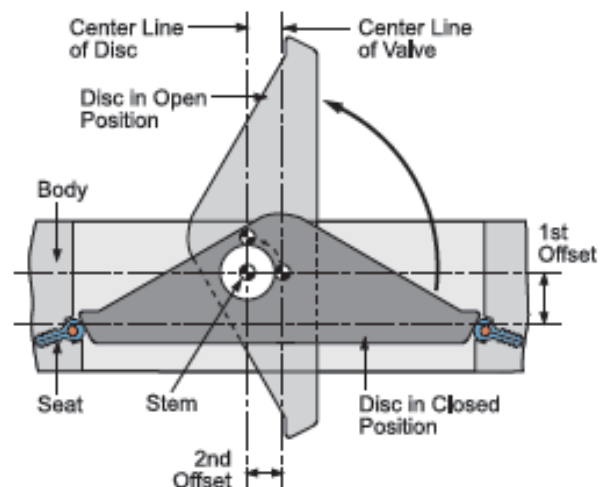
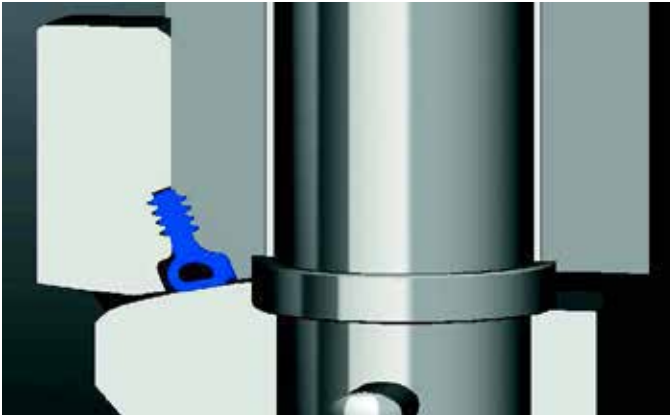

Figure 1: Double offset operating principles

Features – Seat Design

Energized Soft Seat Design

The Masoneilan 39004 High Performance Butterfly Valve Includes unique valve seal designs for soft seal and fire-safe configurations.



The 39004 Series soft seal design provides a bi-directional bubble tight shutoff (zero leakage) through the use of a patented seal. This unique, two-part seat assembly includes a resilient energized system that is completely encapsulated by the seat. Advantages include:

- Under higher pressure conditions, the seal is engineered to confine and direct the movement of the soft seal against the disc edge up to the full range of ASME Class 150, 300 and 600 Cold Working Pressures.
- The soft seal is designed for high services with minimal wear and low torque.
- Seal replacement is a simple procedure requiring no special tools.
- Seal energizing system is completely isolated from all contact with line media by the seat. Line media is sealed to zero-leakage in both directions.
- Seat self-adjusts for wear and temperature changes.
- Disc and line pressure energize the seal as pressure is increased. Higher pressures lead to tighter shutoff yielding superior sealing capabilities over longer service life.



Fire-Safe Seat Design

The fire-safe seal design incorporates two seal designs which function together to seal off pipeline flow. In normal operation, the soft seal provides a bi-directional “bubble tight” shutoff (zero leakage) across the full range of rated pressures and temperatures. The metal seal offers bi-directional shutoff in the event of a fire in conformance to industry fire-safe requirements.

With little or no pressure, the fire-safe seal creates a self-energized seal against the disc. Higher line pressures act on the geometry of both seals to dynamically load them against the disc creating higher sealing forces in either direction. If excessive heat destroys the resilient seated materials, either partially or completely, the seat provides a constant metal-to-metal backup seal.

In real fire conditions, line pressure is immediately reduced and the entire area is hosed down. The resulting pressure drop and rapid cool down causes many valves to fail. The 39004 Series fire-safe design does not rely on line media pressure to seal; therefore, the valve offers superior low pressure performance compared to competitive designs. The Inconel alloy seat offers better corrosion resistance and greater strength than the stainless steel seats commonly used.

This fire-safe design has been tested and certified to API 607, 5th edition fire-safe standards.



Metal Seat Design

An optional metal to metal seat is available for applications requiring erosion resistance and higher operating temperatures. The inconel 718 seat design provides better than class IV shutoff in both flow directions.

This design also comes with a nitrided stainless steel disc for increased mechanical cycle life. Special metal seat constructions are available to handle those applications above 500°F (260°C).

Features – Actuator

Series 96/97 Pneumatic Actuator

Masoneilan Series 96/97 Pneumatic Actuator is a rack and pinion, opposed-piston actuator available in a double acting option for 90°, 135° and 180° rotations as well as a spring return option for 90° rotation. It is ideal for use on the Masoneilan 39004 Series High Performance Butterfly Valve in either automated on/off or throttling service. The Series 96/97 is available in nine different sizes for application flexibility. Plus, the low friction design makes the Series 96/97 well suited to handle offset loads to the gear and output shaft assembly. Some of the key features include:

- QQ Integral Passages – Reduces cost of external tubing.
- QQ Piston Guides and Rings – Provides low friction coefficient and absorbs the side thrusts of the pistons extending the valve package service life.
- Output Shaft Bearings – Low-friction steel design provides extended service life in both on/off and throttling environments.
- QQ Output Shaft and Pinion Gear – One-piece, manufactured from hardened steel and zinc-plated for corrosion protection.
- QQ Shaft Position Indicator – Shows clear open / close position and easily removable for manual override.
- QQ Body – Extruded aluminum with anodized corrosion protective coating.
- QQ End Caps – Polyester-coated for added chemical resistance.
- QQ Travel Stop – Supports travel limits in both open and close directions.
- QQ Pistons – Die-cast aluminum.
- QQ Pneumatic Supply Ports – ¼" NPT NAMUR interface is standard on all actuator sizes.

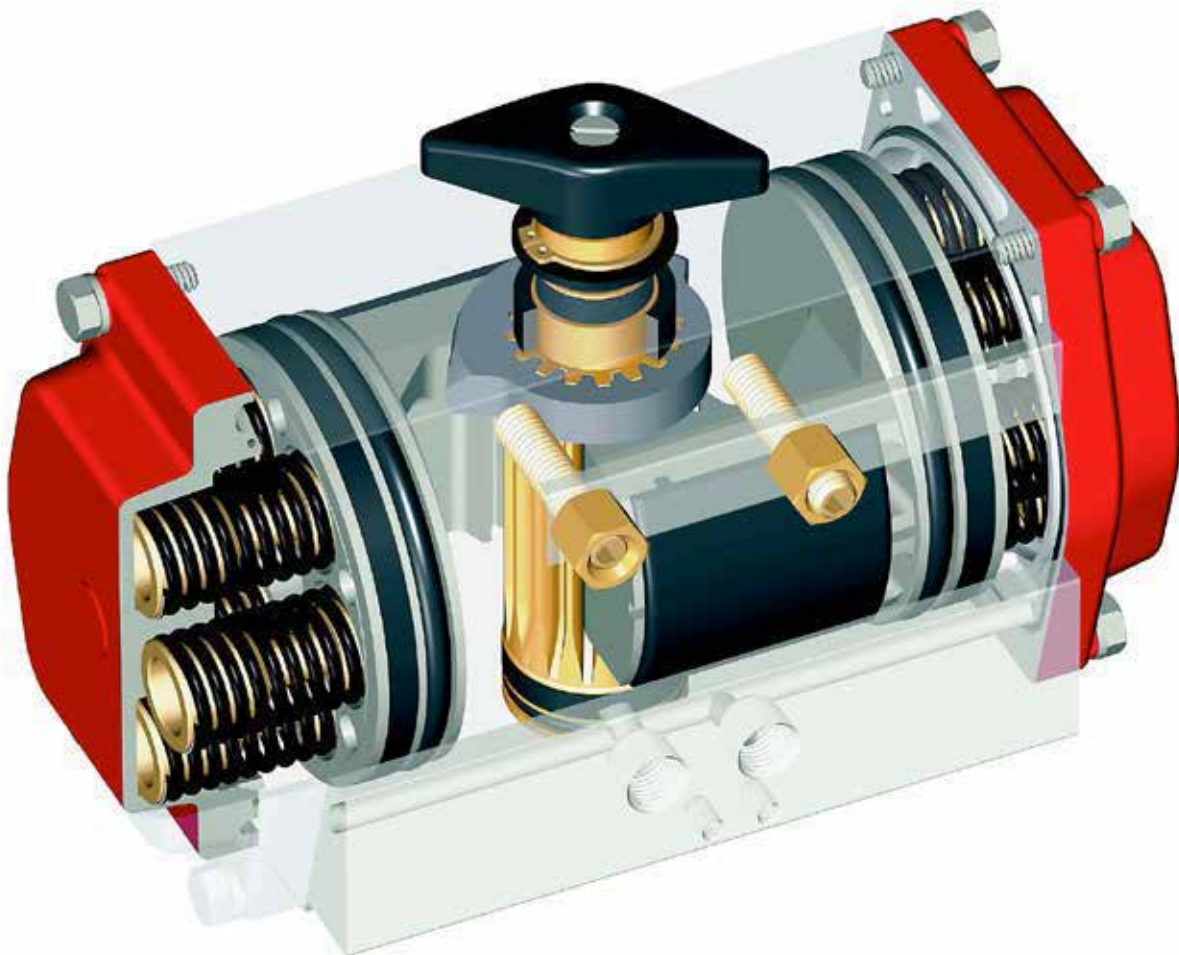

Numbering System

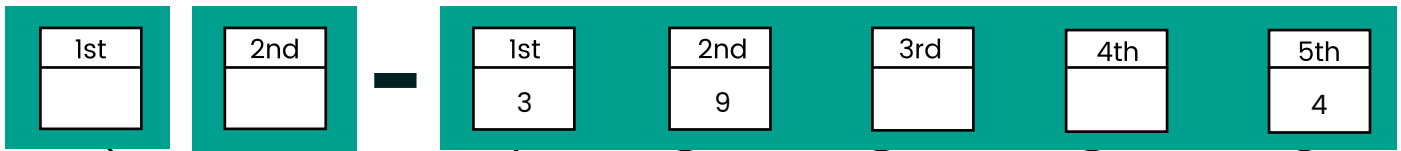

Actuator Type
96 Double Acting Rack & Pinion
97 Spring Return Rack & Pinion
34 Double Acting or Spring Return Piston

Body Series
39

Actuator Configuration
0 Undefined
1 Parallel to Pipe Air to Open
2 Parallel to Pipe Air to Close
3 Perpendicular to Pipe Air to Open
4 Perpendicular to Pipe Air to Close
5 Parallel to Pipe Air to Open
6 Parallel to Pipe Air to Close
7 Perpendicular to Pipe Air to Open
8 Perpendicular to Pipe Air to Close

Seal Type
1 RTFE Seal
2 Fire-Safe Seal
3 Metal Seat (Optional)

Design Series
4

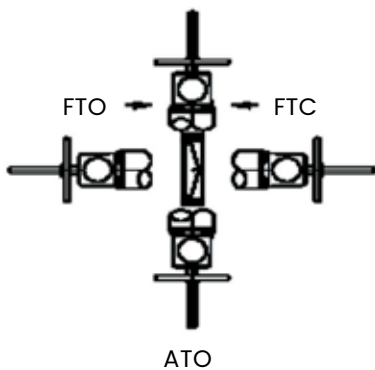

FLOW TO CLOSE

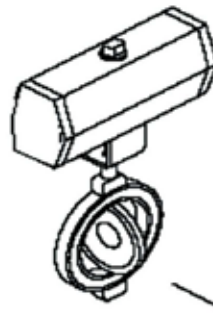

FLOW TO OPEN

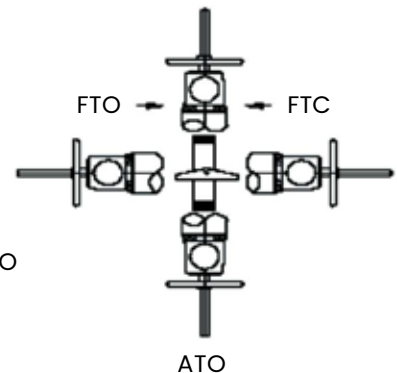

General Data

Seal Leakage

- Per ASME FCI 70-2
- Class VI – RTFE, Fire-Safe
- Class IV – Metal

Actuator Type

Pneumatic Rack and Pinion Actuator options:

- Pneumatic Spring Return (97)
- Pneumatic Double Acting (96)

Pneumatic Scotch Yoke Actuator (34) options:

- Pneumatic Spring Return (SR)
- Pneumatic Double Acting (DA)

Handwheel

Optional

Valve Size		Carbon Steel & Stainless Steel		
inches	mm	ASME 150	ASME 300	ASME 300
3	80	•	•	•
4	100	•	•	•
6	150	•	•	•
8	200	•	•	•
10	250	•	•	•
12	300	•	•	•
14	350	•	•	•
16	400	•	•	•
18	450	•	•	
20	500	•	•	
24	600	•	•	
30	750	•	•	
36	900	•		
42	1050	•		
48	1200	•		

Consult factory for additional sizes and materials.

Pressure/Temperature Ratings

Soft, Metal ($\leq 500^{\circ}\text{F}$), and Fire-Safe Seal

As temperature increases, the pressure retaining capability of materials decreases. The graph below illustrates the pressure/temperature ratings for ASME Class 150, Class 300 and Class 600.

Seal ratings are based on differential pressure with the disc in the fully closed position.[†]

Steam Service (Soft Seal only)

RTFE sealed valves are rated for 50 psi saturated steam.

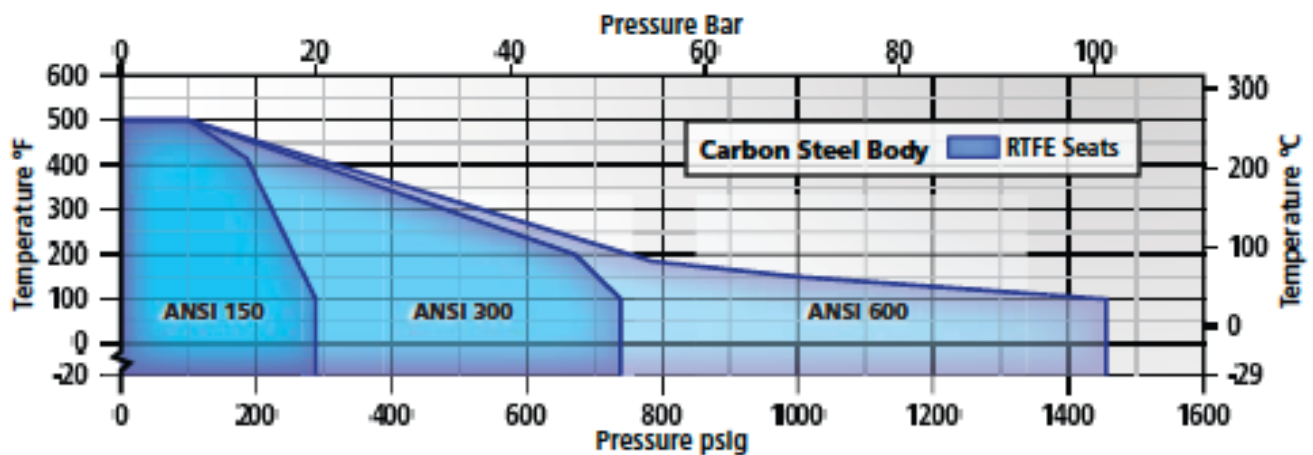
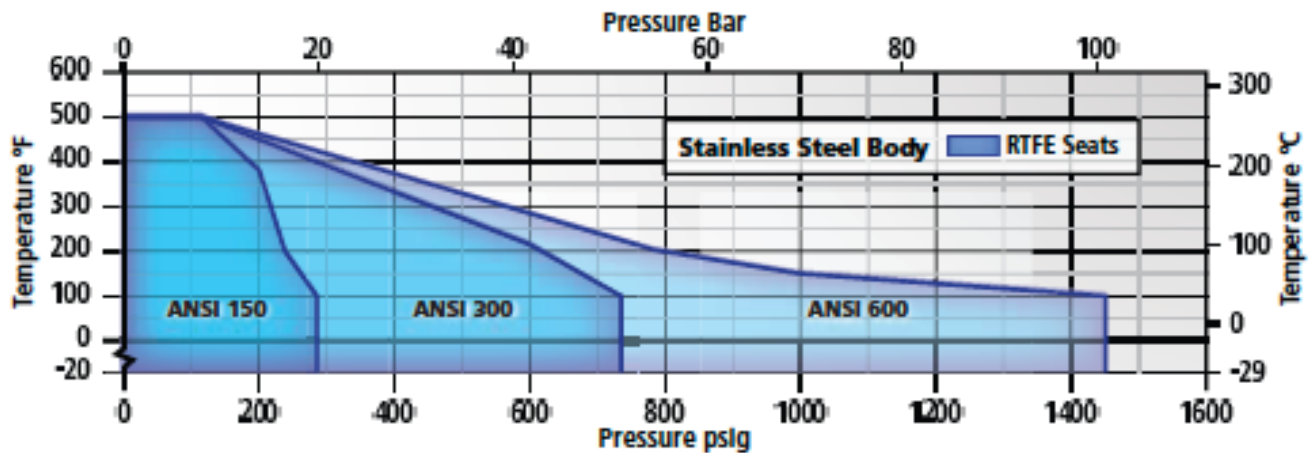

Body Assembly Data

Body

Type:	Wafer or Lugged
Sizes:	3" thru 48" (80 mm-1200 mm)
Materials:	Carbon Steel ASTM A216 GR WCB/A516 GR 70 Stainless Steel ASTM A351 GR CF8M
Connections:	Flangeless - Clamped between ASME Class 150, 300 or 600 line flanges Flanged - Bolts between ASME Class 150, 300 or 600 line flanges
Ratings:	ASME Class 150 - carbon steel and stainless steel 3" - 48" sizes (50 mm-1200 mm) ASME Class 300 - carbon steel and stainless steel 3" - 30" sizes (50 mm-750 mm) ASME Class 600 - carbon steel and stainless steel 3" - 16" sizes (50 mm-400 mm)
Seal:	RTFE, Fire-Safe, or Metal Seated

Disc

Type:	Double Offset Eccentric
Materials:	Stainless Steel ASTM A351 GR CF8M (Standard) Electroless Nickel Plating on Edge (Fire-Safe)

Shaft

Type:	Flats on outboard end (up to 12" on ASME 150, 8" on ASME 300, 6" on ASME 600) Keyed on outboard end (larger sizes)
Materials:	17-4 PH Stainless Steel, ASTM A564-Type 630
Valve Bearings:	316 Stainless Steel with TFE & Glass Fabric Liner
Packing Box:	Bolted
Packing:	PTFE rings plus 1 Carbon Fiber Ring (Standard) Flexible Graphite Rings (Fire Safe)

Actuator Data

(Model 96/97) – Valve Sizes 3"–18" (80 mm–450 mm)

Type:	Series 96 – Rack and Pinion, opposed-piston, double acting Series 97 – Rack and Pinion, opposed-piston, spring return
Body:	Extruded Aluminum Alloy, anodized
Pressure Rating:	140psi (10 bar) maximum working pressure
Seals:	Buna-N
Manual Override:	Declutchable – Optional
Options:	Polyester Coated Body Exterior Electroless Nickel Plated Body Exterior Hard Anodized Body Exterior Stainless Steel Pinion

(Model 34) – Valve Sizes 3"–48" (80 mm–1200 mm)

Type:	Spring-return, or double-acting scotch yoke piston
Body:	Extruded aluminum, anodized finish Ductile Iron
Seals:	Buna-N
Pressure rating:	200 psi (14 bar) maximum working pressure
Manual Override:	Optional

Materials of Construction

The values shown are for the valve installed in the Seal Up Stream (“SUS”) position

Valve Size	ASME Class	Disc Position (Degrees)								
		10	20	30	40	50	60	70	80	90
3	150	5	14	32	56	87	123	155	178	185
	300	5	14	32	56	87	123	155	178	185
	600	3	8	12	46	67	103	135	158	165
4	150	10	31	63	115	175	250	315	365	375
	300	10	31	63	115	175	250	315	365	375
	600	5	30	45	70	95	150	210	270	300
6	150	35	81	140	218	330	510	750	1070	1350
	300	26	79	138	240	370	530	710	875	1000
	600	15	70	130	200	270	425	600	765	850
8	150	65	165	280	456	685	1060	1590	2230	2800
	300	47	121	240	405	630	950	1360	1720	2000
	600	20	78	209	345	480	750	1050	1350	1500
10	150	100	250	450	700	1050	1630	2430	3450	4300
	300	31	150	295	510	780	1200	1740	2250	2650
	600	40	140	300	500	700	1100	1540	1970	2200
12	150	155	390	700	1080	1630	2530	3750	5330	6650
	300	92	220	430	710	1100	1690	2500	3400	4000
	600	55	190	400	680	1000	1550	2170	2790	3100
14	150	175	450	810	1250	1890	2900	4300	6100	7650
	300	100	240	490	830	1200	1770	2600	3500	4100
	600	70	200	420	730	1100	1570	2400	3300	3900
16	150	230	580	1020	1530	2420	3700	5510	7860	9800
	300	180	420	730	1160	1840	2970	4880	6540	7800
	600	95	250	500	800	1200	1900	2900	4200	5000
18	150	170	500	1180	2220	3520	5100	6960	9100	10500
	300	94	440	1080	1970	3110	4530	6170	8000	9500
20	150	200	640	1530	2820	4500	6500	8800	11700	13500
	300	110	530	1250	2330	3720	5400	7300	9570	11000
24	150	240	920	2200	3880	6640	9570	12800	17100	20000
	300	180	830	2000	3700	5920	8570	11400	15100	18000
30	150	320	1510	3600	6700	10700	15500	20900	27300	32000
	300	290	1330	3230	6000	8500	13700	18900	24400	29000
36	150	480	2260	5430	10200	16400	23200	31700	41100	48500
42	150	700	3700	9000	16000	25000	35000	46100	58000	65000
48	150	920	4600	11000	20000	29100	43600	63700	80900	91000

Pressure Recovery Coefficients (F_L)

Value F_L , X_T , X_C as a Function of Disc Rotation

Disc Degree Opening		15	20	25	30	35	40	45	50	55	60	65	70	75	80	85	90
Seat Upstream (FTO)	F_L	0.93	0.92	0.91	0.9	0.87	0.86	0.85	0.81	0.78	.075	0.74	0.69	0.65	0.6	0.55	0.5
	X_T	0.73	0.71	0.70	0.68	0.64	0.62	0.61	0.55	0.51	0.47	0.46	0.40	0.35	0.30	0.25	0.21
	X_C	0.69	0.68	0.66	0.65	0.61	0.59	0.58	0.52	0.49	0.45	0.44	0.38	0.34	0.29	0.24	0.20
Seat Downstream (FTC)	F_L	0.92	0.9	0.91	0.91	0.88	0.83	0.83	0.79	0.73	0.68	0.67	0.65	0.6	0.55	0.52	0.50
	X_T	0.71	0.68	0.70	0.70	0.32	0.58	0.58	0.52	0.45	0.39	0.38	0.35	0.30	0.25	0.23	0.21
	X_C	0.68	0.65	0.66	0.66	0.62	0.55	0.55	0.50	0.43	0.37	0.36	0.34	0.29	0.24	0.22	0.20

Materials of Construction

Blow-Out Proof Stem

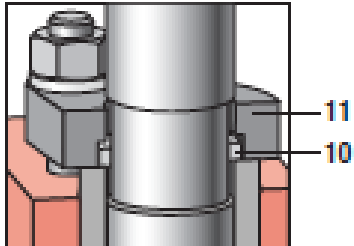

Fire Safe Valve

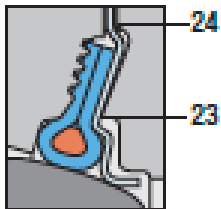

Exploded View

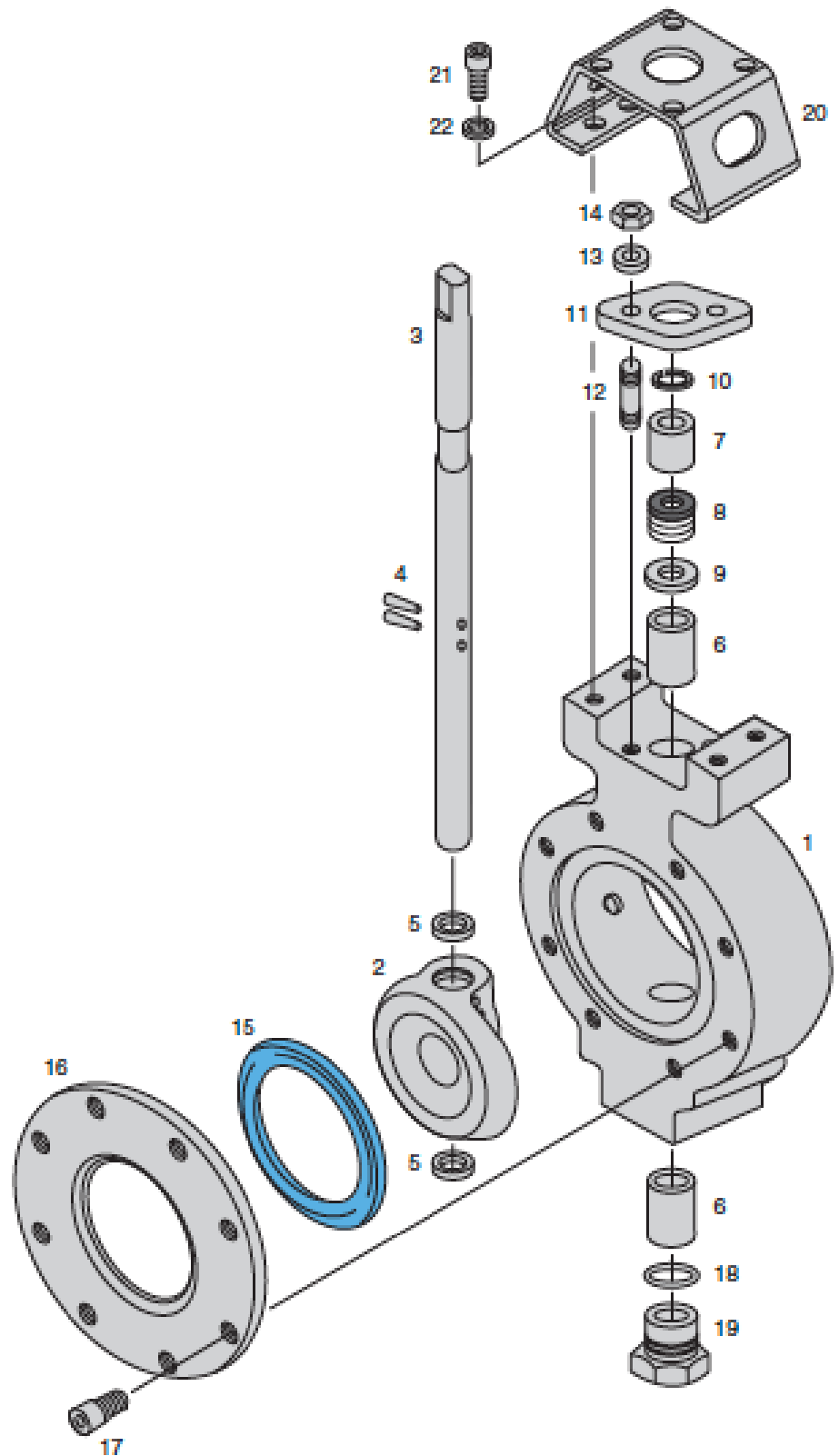

Materials of Construction

Item	Name	Material
1	Body	Stainless Steel, ASTM A351 GR CF8M Carbon Steel, ASTM A216 GR WCB/A516 GR 70
2	Disc	Stainless Steel, ASTM A351 GR CF8M – Standard with Electroless Nickel Plating on disc edge – Fire Safe with Nitriding – Metal Seat
3	Stem	17-4 PH SS, ASTM A564-Type 630
4	Taper Pins	17-4 PH SS, ASTM A564-Type 630
5	Disc Spacers	316 Stainless Steel, ASTM 276 Type 316
6	Bearing Assembly	316 Stainless Steel with TFE & Glass Fabric Liner 316 Stainless Steel Nitrided ³
7	Gland Ring	316 Stainless Steel, ASTM 276 Type 316
8	Stem Seal	PTFE rings plus 1 Carbon Fiber ring – Standard Valve Flexible Graphite rings – Fire Safe and Metal Seat Valve
9	Thrust Washer	316 Stainless Steel, ASTM 276 Type 316
10	Retaining Ring	18-8 Stainless Steel
11	Gland Retainer	316 Stainless Steel, ASTM A351 CF8M Carbon Steel, ASTM A216 GR WCB/A516 GR 70
12	Stud	316 Stainless Steel, ASTM A193-B8M
13	Lock Washers	18-8 Stainless Steel
14	Hex Nut	18-8 Stainless Steel
15	Seat Assembly	RTFE ¹ with Silicone Rubber Energizer
16	Seat Retainer Plate	Stainless Steel, ASTM A351 CF8M/A240-316 Carbon Steel, ASTM A216 GR WCB/A516 GR 70
17	Cap Screws	18-8 Stainless Steel Alloy Steel
18	Gasket	PTFE – Standard Valve Flexible Graphite – Fire Safe Valve ³
19	Locating Plug	316 Stainless Steel, ASTM 276 Type 316/A240-316 Carbon Steel, Phosphate Coated
20	Mounting Plate	18-8 Stainless Steel Carbon Steel, Phosphate Coated
21	Cap Screws	18-8 Stainless Steel Alloy Steel
22	Lock Washers	18-8 Stainless Steel Alloy Steel
23	Metal Seat ²	Inconel [®] 718, ASTM B670
24	Gasket ²	Flexible Graphite

Not Shown: Bellville Washer and Grounding Washer: 18-8 Stainless Steel, for
14"-48" Class 150, 14"-48" Class 300 and 10"-30" Class 600 valves

1. RTFE is supplied as RPTFE (reinforced polytetrafluoroethylene).

2. Fire Safe and Metal Seat Valve only.

3. Used on Metal Seat above 500°F.

Note: Other materials are available, please consult factory for your specific application.

Series 39004 Dimensions

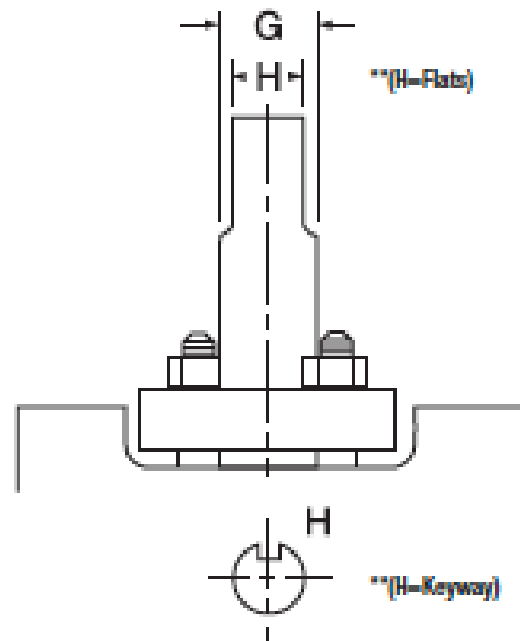
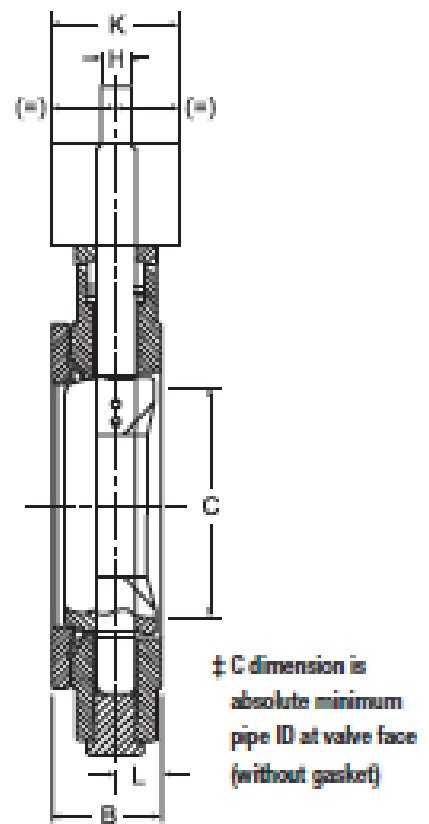
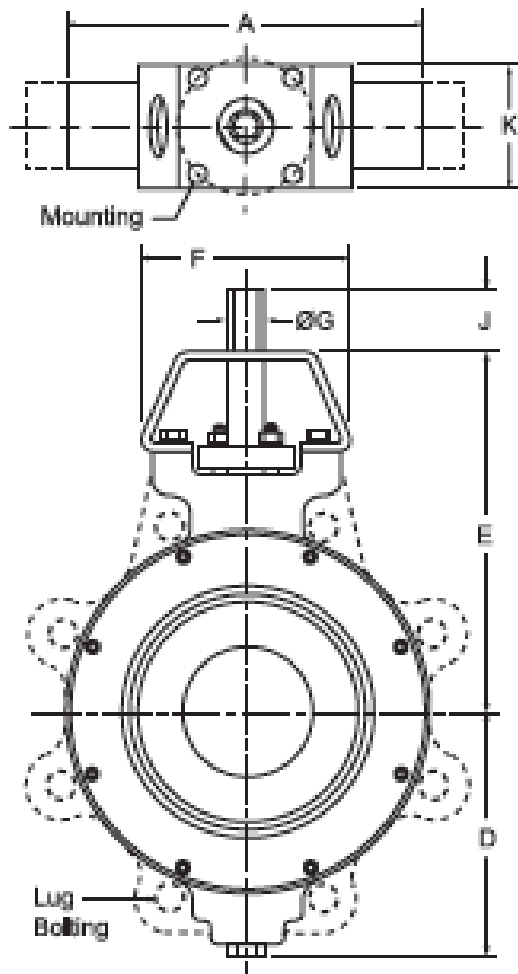

** Keyway is applicable on valve sizes 14"-48" Class 150, 10"-48" Class 300, and 8"-30" Class 600.

Series 39004 Dimensions

ASME 150 (inches)

Valve Size Inches	A	B	C ³	D	E	F	Dia.G	H ²	J	K	L	Lug Bolting Data		
												BCD ¹	# HOLES	UNC-2B
3	5.25	1.88	2.86	4.09	6.63	4.36	0.63	0.43	1.25	2.50	0.77	6.00	4	5/8-11
4	6.75	2.03	3.72	4.71	7.50	4.36	0.63	0.43	1.25	2.50	0.75	7.50	8	5/8-11
6	8.62	2.23	5.88	5.57	8.00	5.12	0.75	0.51	1.25	4.50	0.94	9.50	8	3/4-10
8	10.75	2.40	7.80	6.94	9.50	5.12	0.87	0.63	1.25	4.50	0.94	11.75	8	3/4-10
10	13.06	2.75	9.78	8.56	10.75	6.012	1.18	0.87	2.00	4.50	1.07	14.2	12	7/8-9
12	15.50	3.08	11.74	10.18	12.25	6.12	1.18	0.87	2.00	4.50	1.13	17.00	12	7/8-9
14	17.50	3.73	12.90	11.95	14.50	7.75	1.38	.39 x .39	2.00	6.50	1.42	18.75	12	1-8
16	19.81	4.11	14.68	12.94	17.75	10.38	1.97	.47 x .39	2.50	6.50	1.66	21.25	16	1-8
18	21.41	4.61	16.60	14.15	20.00	10.38	1.97	.47 x .39	2.50	6.50	1.86	22.75	16	1 1/8-8
20	23.68	5.03	18.50	15.26	22.75	10.38	2.50	.62 x .62	4.00	6.50	2.06	25.00	20	1 1/8-8
24	28.00	6.00	22.50	18.21	25.00	15.38	3.00	.75 x .75	4.00	11.75	2.44	29.50	20	1 1/4-8
30	34.50	7.50	28.31	21.35	28.75	19.50	3.50	.88 x .62	5.25	13.50	3.10	36.00	28	1 1/4-8
36	40.68	8.26	34.00	25.27	33.00	19.50	3.50	.88 x .62	5.25	13.50	3.35	42.75	32	1 1/2-8
42	53.31	9.50	39.05	29.37	38.00	19.50	4.50	1.0 x .75	5.25	13.50	4.38	49.50	35	1 1/2-8
48	54.00	10.00	46.09	33.12	42.13	24.00	5.00	1.25 x .88	6.00	16.00	4.50	56.00	44	1 1/2-8

1. Bolt Circle Diameter - applies only to lugged bodies.

2. Keyway applicable on valve sizes 14"-48" (CL150).

3. C dimension is absolute minimum pipe ID at valve face (without gasket).

Series 39004 Dimensions

ASME 150 (mm)

Valve Size mm	A	B	C+	D	E	F	Dia. G	H ²	J	K	L	Lug Bolting Data		
												BCD ¹	# HOLES	UNC-2B
80	133.4	47.8	72.6	103.9	168.4	110.7	16.0	10.9	31.8	63.5	19.6	152.40	4	5/8-11
100	171.5	51.6	94.5	119.6	190.5	110.7	16.0	10.9	31.8	63.5	19.1	190.50	8	5/8-11
150	218.9	56.6	149.4	141.5	203.2	130.0	19.1	13.0	31.8	114.3	23.9	241.30	8	3/4-10
200	273.1	61.0	198.1	176.3	241.3	130.0	22.1	16.0	31.8	114.3	23.9	298.45	8	3/4-10
250	331.7	69.9	248.4	217.4	273.1	155.4	30.0	22.1	50.8	114.3	27.2	361.95	12	7/8-9
300	393.7	78.2	298.2	258.6	311.2	155.4	30.0	22.1	50.8	114.3	28.7	431.80	12	7/8-9
350	444.5	94.7	327.7	303.5	368.3	195.9	35.1	9.9 x 9.9	50.8	165.1	36.1	476.25	12	1-8
400	503.2	104.4	372.9	328.7	450.9	263.7	50.0	11.9 x 9.9	63.5	165.1	42.2	539.75	16	1-8
450	543.8	117.1	421.6	359.4	508.0	263.7	50.0	11.9 x 9.9	63.5	165.1	47.2	577.85	16	1 1/8-8
500	601.5	128.8	469.9	387.6	577.9	263.7	63.5	15.7 x 15.7	101.6	165.1	52.3	635.00	20	1 1/8-8
600	711.2	152.4	571.5	462.5	635.0	390.7	76.2	19.1 x 19.1	101.6	298.5	62.0	749.30	20	1 1/4-8
750	876.3	190.5	719.1	542.5	730.3	495.3	88.9	22.4 x 14.7	133.4	342.9	78.7	914.40	28	1 1/4-8
900	1033.3	209.8	863.6	641.9	838.2	495.3	88.9	22.4 x 15.7	133.4	342.9	92.2	1085.85	32	1 1/2-8
1050	1354.1	241.3	991.9	746.0	965.2	495.3	114.3	25.4 x 19.1	133.4	342.9	111.3	1257.30	35	1 1/2-8
1200	1371.6	254.0	1170.7	841.2	1070.1	609.6	127.0	31.8 x 22.4	152.4	406.4	114.3	56.00	44	1 1/2-8

1. Bolt Circle Diameter - applies only to lugged bodies.
2. Keyway applicable on valve sizes 350-1200mm (CL150).
3. C dimension is absolute minimum pipe ID at valve face (without gasket).

Series 39004 Dimensions

ASME 300 (inches)

Valve Size Inches	A	B	C+	D	E	F	Dia. G	H ²	J	K	L	Lug Bolting Data		
												BCD ¹	# HOLES	UNC-2B
3	5.25	1.88	2.86	4.09	6.63	4.36	0.63	0.43	1.25	2.50	0.77	6.62	8	3/4-10
4	6.75	2.03	3.72	4.71	7.50	4.36	0.63	0.43	1.25	2.50	0.75	7.88	8	3/4-10
6	8.88	2.42	5.75	6.25	8.75	5.12	0.87	0.63	1.25	4.50	0.97	10.62	12	3/4-10
8	10.94	2.82	7.56	7.55	10.00	6.12	1.18	0.87	2.00	4.50	1.10	13.00	12	7/8-9
10	13.26	3.28	9.44	9.36	11.38	6.12	1.18	.39 x .39	2.00	4.50	1.28	15.25	16	1-8
12	15.57	3.62	11.31	10.89	13.50	7.75	1.38	.39 x .39	2.00	6.50	1.40	17.75	16	1 1/8-8
14	17.90	4.66	11.38	12.50	18.25	10.38	1.97	.47 x .39	2.50	6.50	2.13	20.25	20	1 1/8-8
16	19.94	5.35	14.31	13.88	21.00	10.38	2.50	.62 x .62	4.00	6.50	2.50	22.50	20	1 1/4-8
18	22.00	5.98	15.00	15.43	21.00	15.38	2.50	.62 x .62	4.00	11.75	2.65	24.75	24	1 1/8-8
20	24.10	6.34	16.50	16.80	22.25	15.38	3.00	.75 x .75	4.00	11.75	2.90	27.00	24	1 1/8-8
24	28.88	7.15	20.68	19.80	26.25	19.50	3.50	.88 x .62	5.25	13.50	3.40	32.00	24	1 1/2-8
30	35.12	8.98	26.81	23.40	32.25	24.00	4.50	1.0 x .75	5.25	16.00	4.38	39.25	28	1 3/4-8

1. Bolt Circle Diameter - applies only to lugged bodies.

2. Keyway applicable on valve sizes 10"-30" (Cl300).

3. C dimension is absolute minimum pipe ID at valve face (without gasket).

ASME 300 (mm)

Valve Size mm	A	B	C+	D	E	F	Dia. G	H ²	J	K	L	Lug Bolting Data		
												BCD ¹	# HOLES	UNC-2B
80	133.35	47.75	72.64	103.89	168.40	110.74	16.00	10.922	31.75	63.50	19.56	168.15	8	3/4-10
100	171.45	51.56	94.49	119.63	190.5	110.74	16.0	10.992	31.75	63.50	19.05	200.15	8	3/4-10
150	225.55	61.47	146.05	158.75	222.25	130.05	22.10	16.002	31.75	114.30	24.64	269.75	12	3/4-10
200	277.88	71.63	192.02	191.77	254.00	155.45	29.97	22.098	50.80	114.30	27.94	330.20	12	7/8-9
250	336.80	83.31	239.78	237.74	289.05	155.45	35.05	9.9 x 9.9	50.80	114.30	32.51	387.35	16	1-8
300	395.48	91.95	287.27	276.61	342.90	196.85	35.05	9.9 x 9.9	50.80	165.10	35.56	450.85	16	1 1/8-8
350	454.66	118.36	289.05	317.50	463.55	263.65	50.04	11.9 x 9.9	63.50	165.10	54.10	514.35	20	1 1/8-8
400	506.48	135.89	363.47	352.55	533.40	263.65	63.50	15.7 x 15.7	101.60	165.10	63.50	571.50	20	1 1/4-8
450	558.80	151.89	381.00	391.92	533.40	390.65	63.50	15.7 x 15.7	101.60	298.45	67.31	628.65	24	1 1/4-8
500	612.14	161.04	419.10	426.72	565.15	390.65	76.20	19.1 x 19.1	101.60	298.45	73.66	685.80	24	1 1/4-8
600	733.55	181.61	525.27	502.92	666.75	495.30	88.90	22.4 x 15.7	133.35	342.90	86.36	812.80	24	1 1/2-8
750	892.05	228.09	680.79	594.36	819.15	609.60	114.30	25.4 x 19.1	133.35	406.340	111.25	996.95	28	1 3/4-8

1. Bolt Circle Diameter - applies only to lugged bodies.

2. Keyway applicable on valve sizes 250-750mm (Cl300).

3. C dimension is absolute minimum pipe ID at valve face (without gasket).

Series 39004 Dimensions

ASME 600 (inches)

Valve Size Inches	A	B	C+	D	E	F	Dia. G	H ²	J	K	L	Lug Bolting Data		
												BCD ¹	# HOLES	UNC-2B
3	5.78	2.22	2.75	5.72	7.00	5.12	0.75	0.51	1.25	4.50	0.90	6.00	4	5/8-11
4	7.00	2.77	3.56	7.04	8.50	5.12	0.87	0.63	1.25	4.50	1.15	7.50	8	5/8-11
6	9.75	3.34	5.38	8.57	9.75	6.12	1.18	0.87	2.00	4.50	1.50	9.50	8	3/4-10
8	11.80	4.23	6.88	10.80	12.25	7.75	1.38	.39 x .39	2.00	6.50	1.90	11.75	8	3/4-10
10	14.09	4.82	8.50	14.62	17.00	10.38	1.97	.47 x .39	2.50	6.50	2.15	14.25	12	7/8-9
12	16.47	5.51	10.12	5.72	18.25	10.38	1.97	.47 x .39	2.50	6.50	2.53	17.00	12	7/8-9
14	18.03	6.09	10.88	17.48	19.75	15.38	2.50	.62 x .62	4.00	11.75	2.90	18.75	12	1-8
16	20.38	7.00	12.62	19.41	21.75	15.38	3.00	.75 x .75	4.00	11.75	3.44	21.25	16	1-8
18	23.15	7.75	14.60	21.05	23.75	19.50	3.50	.88 x .62	5.25	13.50	3.60	22.75	16	1/18-8
20	25.15	8.50	16.37	23.21	25.75	19.50	4.00	1.0 x .75	5.25	13.50	3.88	25.00	20	1/18-8
24	29.38	9.13	19.87	27.71	31.00	24.00	5.00	1.25 x .88	6.00	16.00	3.94	29.50	20	1/14-8

1. Bolt Circle Diameter - applies only to lugged bodies.
2. Keyway applicable on valve sizes 8"-24" (CL600).
3. C dimension is absolute minimum pipe ID at valve face (without gasket).

ASME 600 (mm)

Valve Size mm	A	B	C+	D	E	F	Dia.G	H ²	J	K	L	Lug Bolting Data		
												BCD ¹	# HOLES	UNC-2B
80	146.81	56.39	69.85	145.03	177.80	130.05	19.05	12.954	31.75	114.30	22.86	168.15	8	3/4-10
100	177.80	70.36	90.42	178.82	215.60	130.05	22.10	16.002	31.75	114.30	29.21	215.90	8	7/8-9
150	247.65	84.84	136.65	217.68	247.65	155.45	29.97	22.098	50.80	114.30	38.10	292.10	12	1-8
200	299.72	107.44	174.75	274.32	311.15	196.85	35.05	9.9 x 9.9	50.80	165.10	48.26	349.25	12	1 1/8-8
250	357.89	122.43	215.90	371.35	431.80	263.65	50.04	11.9 x 9.9	63.50	165.10	54.61	431.80	16	1 1/4-8
300	418.34	139.95	257.05	145.29	463.55	263.65	50.04	11.9 x 9.9	65.50	165.10	64.26	488.95	20	1 1/4-8
350	457.96	154.69	276.35	443.99	501.65	390.65	63.50	15.7 x 15.7	101.60	298.45	73.66	527.05	20	1 3/8-8
400	517.65	177.80	320.55	493.01	552.45	390.65	76.20	19.1 x 19.1	101.60	298.45	87.38	603.25	20	1 1/2-8
450	588.01	196.85	390.84	534.67	603.25	495.30	88.90	22.4 x 15.7	133.35	342.90	91.44	654.05	20	1 5/8-8
500	638.81	215.90	415.80	589.53	654.05	495.30	101.60	25.4 x 19.1	133.35	342.90	98.55	723.90	24	1 5/8-8
600	746.25	231.90	504.70	703.83	787.40	609.60	127.00	31.8 x 22.4	152.40	406.40	100.08	838.20	24	1 7/8-8

1. Bolt Circle Diameter - applies only to lugged bodies.
2. Keyway applicable on valve sizes 200-600mm (CL600).
3. C dimension is absolute minimum pipe ID at valve face (without gasket).

Series 39004 Weights (lbs)

Valve Size	ASME 150		ASME 300		ASME 600	
Inches	Wafer	Lugged	Wafer	Lugged	Wafer	Lugged
3	16	15	16	17	24	31
4	20	23	20	23	41	58
6	33	47	40	54	79	119
8	46	54	68	89	155	227
10	79	94	113	144	280	400
12	123	136	173	217	386	547
14	208	227	328	444	549	750
16	313	345	455	592	752	1100
18	402	442	605	856	1090	1470
20	527	604	780	1050	1360	1850
24	813	930	1260	1720	2160	2900
30	1475	1740	2260	3010	-	-
36	1960	2600	-	-	-	-
42	4250	4300	-	-	-	-
48	4610	5680	-	-	-	-

Series 39004 Weights (kg)

Valve Size	ASME 150		ASME 300		ASME 600	
Inches	Wafer	Lugged	Wafer	Lugged	Wafer	Lugged
80	7.3	6.8	7.3	7.7	10.9	14.1
100	9.1	10.4	9.1	10.4	18.6	26.3
150	15	21.3	18.1	24.5	35.8	54
200	20.9	24.5	30.8	40.4	70.3	103
250	35.8	42.6	51.3	65.3	127	181.4
300	55.8	61.7	78.5	98.4	175.1	248.1
350	94.3	103	148.8	201.4	249	340.2
400	142	156.5	206.4	268.5	341.1	499
450	182.3	200.5	274.4	388.3	494.4	666.8
500	239	274	353.8	476.3	616.9	839.1
600	368.8	421.8	571.5	780.2	989.8	1315.4
750	669	789.3	1025.1	1365.3	-	-
900	889	1179.6	-	-	-	-
1050	1927.8	1950.4	-	-	-	-
1200	2091.1	2576.4	-	-	-	-

Actuator Dimensions

Double acting/spring return

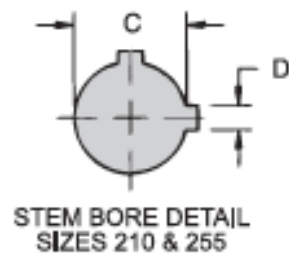
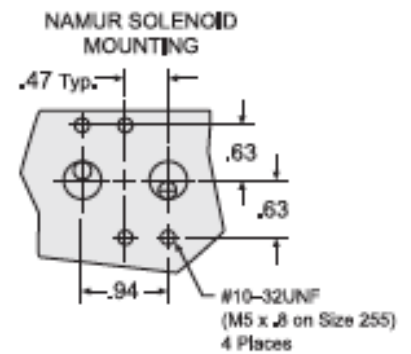
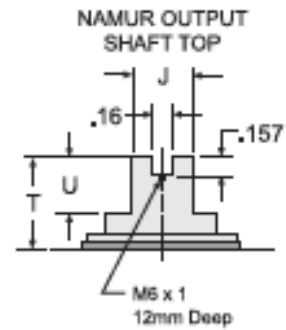
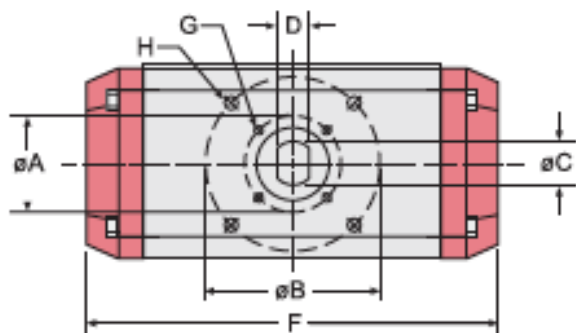
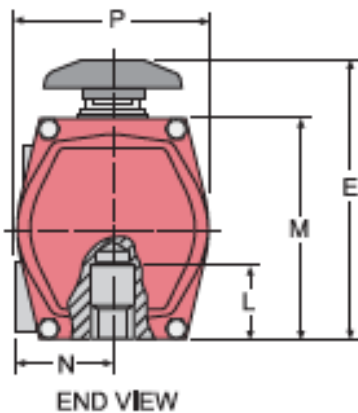
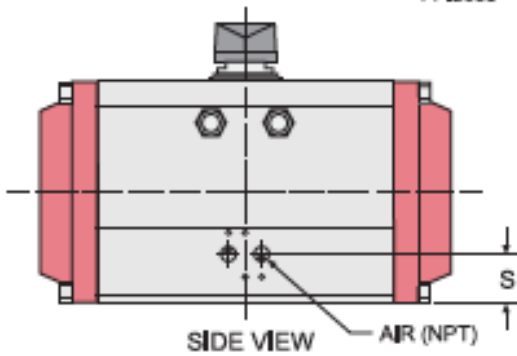
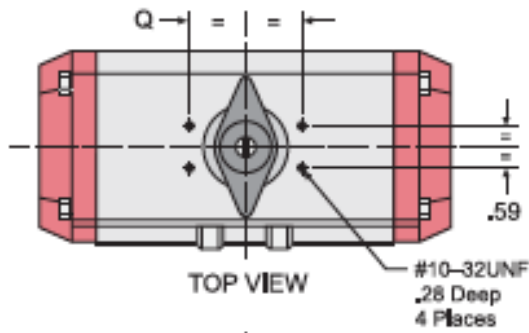

Actuator Dimensions

Series 96/97 Dimensions (inches)

Size	63	83	93	119	128	160 ¹	210	255 ²
AIR NPT	1/4	1/4	1/4	1/4	1/4	1/4	1/4	1/4
A ISO "F"	1.97 F 05	1.97 F 05	1.97 F 05	2.76 F 07	2.76 F 07	N/A	4.92 F 12	6.50 F 16
B ISO "F"	2.76 F 07	2.76 F 07	2.76 F 07	4.92 F 12	4.92 F 12	4.92 F 12	6.50 F 16	7.87 x 4.72 Rect.
C	0.55	0.75	0.75	1.18	1.18	1.18	1.97	2.50
D	0.40	0.51	0.51	0.87	0.87	0.87	0.47	0.62
E	4.53	5.43	5.78	7.28	8.09	9.36	11.45	13.35
F	5.58	7.40	9.10	12.40	12.81	15.54	17.80	26.70
G (UNC)	1/4-20 x .32	1/4-20 x .32	1/4-20 x .32	5/16-18 x .46	5/16-18 x .46	N/A	1/2-13 x .78	M16x2 x 28mm
H (UNC)	5/16-18 x .32	5/16-18 x .40	5/16-18 x .40	1/2-13 x .69	1/2-13 x .69	1/2-13 x .75	5/8-11 x 1.11	M16x2 x 28mm
J	0.38	0.50	0.50	1.12	1.12	1.12	1.12	1.12
L	1.38	1.46	1.46	2.20	2.20	2.20	2.76	4.25
M	3.46	4.27	4.61	5.52	6.32	7.80	10.40	11.89
N	1.72	2.02	2.47	2.78	2.88	3.07	4.25	4.75
P	3.11	3.83	1.97	2.37	2.70	6.82	8.83	10.75
Q	1.58	1.58	1.58	1.58	1.58	2.56	2.56	2.56
S	0.89	0.89	1.32	1.64	1.64	1.39	1.44	1.50
T	0.79	0.79	0.79	0.79	0.79	1.18	1.18	1.18
U	0.47	0.47	0.47	0.47	0.47	0.75	0.75	0.75

Note: Double Acting and Spring Return actuators have the same overall dimensions. ISO "F" means mounting flange-drilling pattern.

1. Dimensions for Size 160A in table. Size 160B (keyed stem version) has C dimension of 1.38 and D dimension of .39.

2. Dimensions for Size 255A in table. Size 255B has C dimension of 3.00 and D dimension of .75.

Actuator Dimensions

Series 96/97 Dimensions (mm)

Size	63	83	93	119	128	160 ¹	210	255 ²
AIR NPT	1/4	1/4	1/4	1/4	1/4	1/4	1/4	1/4
A ISO "F"	50.0 F 05	50.0 F 05	50.0 F 05	70.1 F 07	70.1 F 07	N/A	125.0 F 12	165.1 F 16
B ISO "F"	70.1 F 07	70.1 F 07	70.1 F 07	125.0 F 12	125.0 F 12	125.0 F 12	165.1 F 16	199.9 x 119.9 Rect.
C	14.0	19.1	19.1	30.0	30.0	30.0	50.0	63.5
D	10.2	13.0	13.0	22.1	22.1	22.1	11.9	15.7
E	115.1	137.9	146.8	184.9	205.5	237.7	290.8	339.1
F	141.7	188.0	231.1	302.3	312.7	394.7	452.1	678.2
G (UNC)	1/4-20 x .32	1/4-20 x .32	1/4-20 x .32	5/16-18 x .46	5/16-18 x .46	N/A	1/2-13 x .78	M16x2 x 28mm
H (UNC)	5/16-18 x .40	5/16-18 x .40	5/16-18 x .40	1/2-13 x .69	1/2-13 x .69	1/2-13 x .75	5/8-11 x 1.11	M16x2 x 28mm
J	9.7	12.7	12.7	28.4	28.4	28.4	28.4	28.4
L	35.1	37.1	37.1	55.9	55.9	55.9	70.1	108.0
M	87.9	108.5	117.1	140.2	160.5	198.1	255.0	302.0
N	43.7	51.3	62.7	64.3	69.1	78.0	108.0	120.7
P	35.3	46.0	50.0	60.5	69.1	95.3	116.3	152.4
Q	40.1	40.1	40.1	40.1	40.1	65.0	65.0	65.0
S	22.6	22.6	33.5	34.5	34.5	35.3	36.6	38.1
T	20.1	20.1	20.1	20.1	20.1	30.0	30.0	30.0
U	11.9	11.9	11.9	11.9	11.9	19.1	19.1	19.1

Note: Double Acting and Spring Return actuators have the same overall dimensions. ISO "F" means mounting flange-drilling pattern.

1. Dimensions for Size 160A in table. Size 160B (keyed stem version) has C dimension of 1.38 and D dimension of .39.

2. Dimensions for Size 255A in table. Size 255B has C dimension of 3.00 and D dimension of .75.

Actuator Weights & Volumes

Series 96/97 Actuator Weights (lbs)

Size	63	83	93	119	128	160	210	255
Double Acting	3.4	6.1	8.4	16.4	20.9	38.1	65.0	144.0
Spring Return	4.1	7.9	10.8	21.7	27.3	52.6	95.3	192.6

Weights are in lbs. Spring Return unit weights are with full set of springs per piston.

Series 96/97 Actuator Weights (kg)

Size	63	83	93	119	128	160	210	255
Double Acting	1.8	3.3	4.5	8.8	11.2	20.4	34.8	77.2
Spring Return	2.2	4.2	5.8	11.6	14.6	28.2	51.1	103.2

Weights are in kg. Spring Return unit weights are with full set of springs per piston.

Series 96/97 Actuator Volumes (cubic inches)

Size	63	83	93	119	128	160	210	255
Double Acting	9.6	24.8	34.8	73.8	96.7	187.5	360.0	750.0
Spring Return	13.4	32.6	45.9	95.5	130.8	259.6	450.0	900.0

Counter-clockwise: Air volume in cubic inches required to push pistons apart, full travel.
Clockwise: Air volume in cubic inches required to push pistons together, full travel.

Series 96/97 Actuator Volumes (cubic cm)

Size	63	83	93	119	128	160	210	255
Double Acting	157	406	570	1,209	1,585	3,073	5,899	12,290
Spring Return	220	534	752	1,565	2,143	4,254	7,374	14,748

Counter-clockwise: Air volume in cubic inches required to push pistons apart, full travel.
Clockwise: Air volume in cubic inches required to push pistons together, full travel.

Options and Accessories

The accessories below are available for mounting with the Series 39004 and Series 96/97 HPBV package. All positioners are available with standard NAMUR mounting.

Product	Available Option
Digital Positioners	SVI™ II AP
	SVI II ESD
	SVI FF
Pneumatic Positioners	4700P
	4700E
Other Options	78 Series Airset
	77 Series Lockup Valve
	4411 I/P
	496 Switches
	Solenoid Valves
	Status Monitors

Consult your local sales contact for additional Options and Accessories.



CONTROLS SUPPLY CHAIN

VALVES ACTUATORS INSTRUMENTATIONS