

Model 4411

Electro-pneumatic Transducer

Modularity for ease of maintenance

General Description

The **Masoneilan™** 4411 proportional I/P converter is a precision electronic pressure controller designed for continuous process control applications. The instrument operates a closed loop system incorporating a feedback sensor, providing long-term stability and high accuracy performance along with “fail-safe” operation, in which the output falls to a low pressure upon loop current failure. Its modularity provides additional ease of maintenance.

The 4411 instrument combines substantial flow capacity with the ability to give precise control into closed volume “dead-end” applications. The instrument was designed to withstand the rigors of industrial environments such as shock, vibration and positional effects. It is available as explosion proof, intrinsically safe and non-incendive. Its vibration immunity and IP66 weatherproof rating make it ideal for field applications.



Technical Data

Pneumatic	
Output Signal	3-15 psig (0.2-1 barg) or 6-30 psig (0.4-2.1 barg)
Air Supply	Oil free, dry air, filtered to 50 microns; Internal built-in air filter
Flow Capacity	> 300 NI/min (12scfm)
Air Consumption	<2.5l/min (0.09 scfm) at 50% signal
Response Time	≤ 1second (from 10 to 90 percent or 90 to 10 percent of output pressure into a 500cc load)
Total Error	≤ 0.1 percent of span for > 500cc load, < 0.15 percent of span for < 10cc load (typical, independent error includes the combined effect of non-linearity, hysteresis, deadzone and repeatability)
Temperature Effect	Typically less than 0.035 percent of span/degC between -40°C to +85°C (-40°F to +185°F)
Supply Sensitivity	Less than 0.1 percent of span over full supply pressure range
Leak Sensitivity	≤ 0.875 percent of span for up to 3.0scfm downstream leakage
Connections	1/4" NPT female standard (plus integral 1/8" NPT gauge ports, 1/8" NPT exhaust baffle)
Physical	
Operating Temperature	-40°C to +85°C (-40°F to +185°F)
Weatherproofing	IP66, NEMA Type 4X
Vibration	Output pressure changes less than 4 percent for vibration amplitude 4mm 5-15Hz, 2g 15-150Hz, 1g 150-1000Hz
Electromagnetic	Compliant with EC requirements: BS EN61000-6-4 – Generic Emissions Standard – Industrial environment BS EN61000-6-2 – Generic Standards – Immunity for industrial environments
Material of Construction	Aluminum and zinc die-casting with nitrile diaphragms, grey epoxy powder coating standard
Mass	2.07Kg (4.6lbs)
Maintenance	Modular Electronics and built-in filter offered as field replaceable parts
Mounting Position	Integral bracket allows for surface or 50mm pipe mounting in any orientation
Electrical	
Electrical Signal	4-20mA (two wire) Terminal voltage < 6.5V
Failure Mode	Signal falls to below 15mbar (0.2psig) in < 2sec, when input signal fails
Insulation Resistance	> 100MΩ at 850Vdc, electrical terminals to case
Connections	1/2" NPT or M20 via adapter; internal terminal block with capacity up to 2.5mm ² cable

Ordering Information

Certification	Output Pressure	Process Connections		Part Number
ATEX, FM & CSA IS/EX/NI	3-15 PSIG	Conduit: 1/2" NPT	Air: 1/4" NPT	011534280-888-0000
ATEX, FM & CSA IS/EX/NI	0.2-1 BAR	Conduit: 1/2" NPT	Air: 1/4" NPT	011534281-888-0000
ATEX, FM & CSA IS/EX/NI	6-30 PSIG	Conduit: 1/2" NPT	Air: 1/4" NPT	011534282-888-0000
ATEX, FM & CSA IS/EX/NI	0.4-2 BAR	Conduit: 1/2" NPT	Air: 1/4" NPT	011534283-888-0000
ATEX, FM & CSA IS/EX/NI	3-15 PSIG	Conduit: M20	Air: 1/4" NPT	011534360-888-0000

Approval Certifications

Refer to Model 4411 Manual Ref. 19084

Basic Dimensions

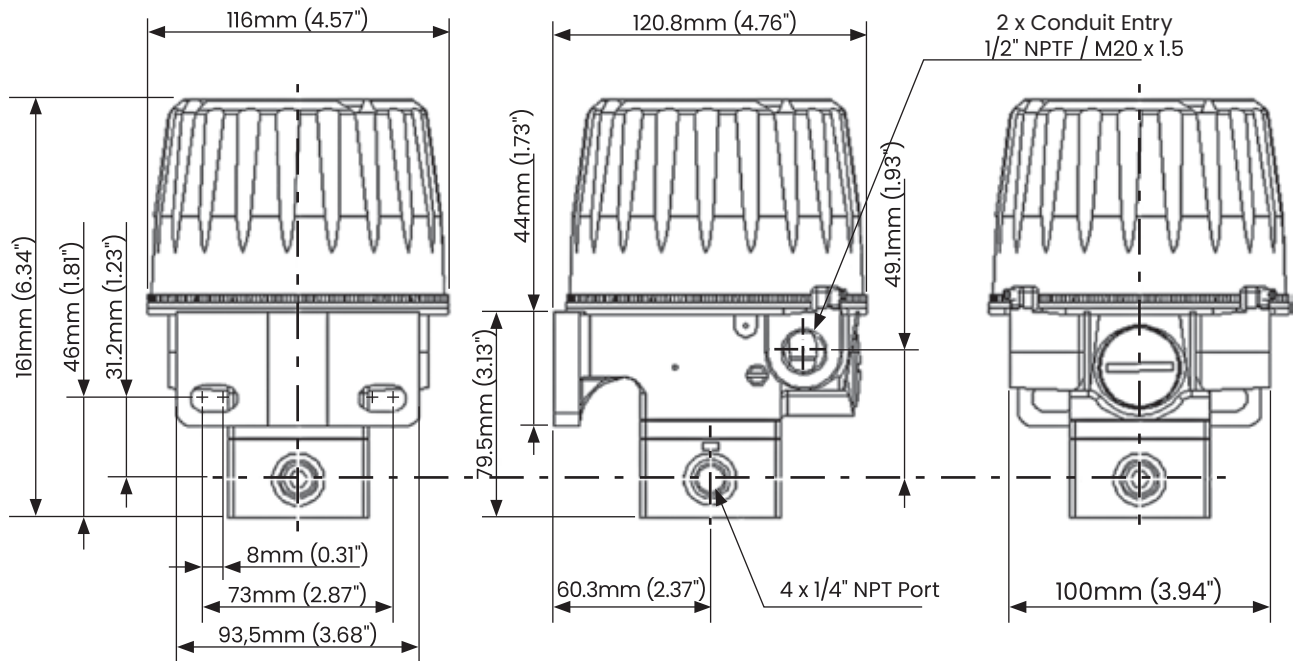

Characteristic Graph

