

# Masoneilan™ 77000/77003 Series

## High-Pressure Labyrinth Trim Control Valve

These valves provide high pressure, compressible fluid control without the erosion, vibration and high noise associated with conventional control valves.



# Table of contents

Features and Benefits .....	3-4
Energy Management Trim .....	3
Smooth, Stable Control .....	3
Cavitation Elimination .....	3
Debris Tolerance .....	3
Reliable Tight Shutoff .....	3
Features and Benefits (cont.).....	4
Configurations .....	4
Ease of Maintenance .....	4
NACE and PED Compliance .....	4
Noise Prediction .....	4
General Data .....	4
Numbering System .....	5
77000/77003 Expanding Area Trim Design.....	6
77003 Series Ratings.....	7
77003 Series - Carbon Steel & CrMo Steel Material Options .....	8
Carbon Steel and CrMo Steel Construction .....	9
Carbon Steel and CrMo Steel Construction for NACE MR 01-75 2002 or MR 01-03 2003...	9
77003 Series - Material Options.....	10
Stainless Steel Construction.....	10
77003 Series - Material Options.....	11
Stainless Steel Construction for NACE MR 01-75 2002 or MR 01-03 2003.....	11
77003 Standard Dimensions .....	11
77000 Series Ratings.....	12
77000 Sizes and Ratings (ANSI Class).....	12
77000 Series Ratings.....	13
77000 Flow Coefficient ( $C_v$ ) and Expansion Ratio.....	13
77000 Series Temperature Range/Seat Leakage.....	13
77001 Series - Bottom Entry Material Options.....	15
77002 Series - Top Entry Material Options.....	17

# Features and Benefits

Masoneilan 77000/77003 series high-pressure labyrinth trim control valve delivers exceptionally stable control and durable service life while saving replacement and maintenance costs. It provides high-pressure, compressible fluid control without the erosion, vibration, and high noise associated with conventional control valves.

Ideal for service in multi-phase flow applications, the 77000/77003 series valve's advanced energy management trim design stands up to the damaging and abrasive conditions caused by two-phase flow and entrained solids. It features an expanding area flow passage, and its multiple step plug and seat ring design creates a beneficial shearing action across each stage to manage the gradual pressure reduction.

## Energy Management Trim

This valve applies the principle of energy management technology to gradually reduce pressure through the creation of flow path friction. This simulates the gradual pressure loss that occurs over long pipelines. By passing the fluid through a number of restrictions, referred to as pressure reduction stages, the Masoneilan 77000/77003 series valve's tortuous flow path dissipates energy through high head loss rather than through shock waves.

Additionally, the flow area of the trim is gradually increased at the latter stages of the design to compensate for the volumetric expansion of the gas caused by the reduction in pressure. This ensures nearly constant fluid velocity throughout the complete throttling process and eliminates the damaging effects of high energy spikes within the trim. The reduced velocity also minimizes the impact of erosion caused by entrained solids or liquids undergoing a phase change. The acoustical performance of the valve is optimized through alignment of the pressure drop ratio with the flow area expansion. In some special cases, downstream Lo-dB cartridges or custom design trim areas are integrated into the control valve design for extremely high-pressure drop ratios.

The unique axial flow construction of the Masoneilan 77000/77003 series valve is optimal for flashing or degassing applications. The axial flow path within the angle body design directs the two-phase fluid away from critical surfaces and away from the downstream pipe wall.

## Smooth, Stable Control

The high rangeability (50:1) of this multi-stage valve allows wide variations in controlled flow. The semi-balanced plug design allows pressurized fluid to fill internal plug ports during intermediate travel positions. This creates a balancing load within the plug to minimize plug forces and provide exceptional control stability. This uniquely balanced trim design has no secondary balancing seal and only a single surface for seat contact.

An available lever design for the actuation system provides high force amplification through mechanical leverage resulting in stable control during the throttling phase.

## Cavitation Elimination

The valve's multi-stage trim design reduces the pressure drop in small increments without allowing the local pressure at each stage to drop below the fluid vapor pressure, thus preventing cavitation. The actively controlled stages of the axial flow trim throttle in unison to avoid the adverse effects of an exaggerated reduction at any single stage.

## Debris Tolerance

Wide flow paths in the trim allow for passage of large particles entrained within the flow stream that would otherwise cause damage or loss of capacity. This ensures continuous and efficient operation by eliminating concerns of potential clogging due to debris in the flow stream. Baker Hughes Masoneilan 77000/77003 series valve offers a proven design for many high-pressure, dirty service applications, including wellhead choke valves.

## Reliable Tight Shutoff

The standard seat design leakage rating meets IEC534-4 and ANSI/FCI 70.2 Class V shutoff requirements. The valve can also be supplied with block valve tight shutoff to comply with MSS-SP-61 specifications.

# Features and Benefits (cont.)

## Configurations Ease of Maintenance

The 77000 Series is offered in two different design concepts. The original 77000 is an angle valve with up to 9 trim stages, and is available in either a bottom bonnet configuration with flanged ends, or in a top bonnet design for both flanged and welded end connections.

The 77003 is a compact version of the original 77000 with either 5 or 3 trim stages, and is available with a top bonnet design for both flanged and welded end connections.

Both designs offer the unique combination of multi-stage axial trim with expanding trim stages to solve the most difficult fluid management applications.

Short valve travel reduces packing wear and significantly extends packing life, particularly in high-pressure/ high-temperature service.

Enhanced service life is achieved through the trim's heavy guiding coupled with the use of hardened materials on the seat and guiding surfaces.

## NACE and PED Compliance

Masoneilan 77000/77003 series valve is available for sour service applications using the design and construction methods defined in NACE standard MR0103. Product configurations for applications requiring MR0175 – 2003 or ISO 15156 compliance are also available. In addition, the valve is designed for compliance with Pressure Equipment Directive (PED) requirements.

## General Data

### Flow Direction

Standard: Flow-to-open (FTO), Up-Seating

### Body

Style: 77000 : Top or bottom entry angle  
77003 : Top entry angle

Type: Cast or forged angle style

Sizes: 1-inch to 8-inch (expanding outlets available) (DN 25 to 200)

Ratings: ANSI Class 600 to 2500 (ISO PN 100 to 420)  
API Class 2000 to 10000

End Connections: RF flange, RTJ flange  
Print flanges (forgings only)  
BWE  
SWE (available for 2-inch and under)

### Bonnet

Type: Bottom entry : bolted outlet spool  
Top entry : bolted bonnet

### Body and Bonnet

Materials: Carbon steel  
Stainless steel  
Chrome-moly steel  
High alloy steel

### Trim

Plug type: Multi-stage axial flow  
Type 77000:

Trim A : 9 stages

Trim B : 5 stages

Trim C : 1 stage

Type 77003:

Trim X : 5-Stage partial-balanced

Trim Y : 3-Stage unbalanced

Seat type: Hard-faced metal seat

Guide: Hard faced top and bottom  
guiding

C<sub>v</sub> Ratio: See flow capacity tables

Flow Characteristic: Modified linear

### Actuator

Mounting: Lever arm mount  
Direct mount

Type: Spring-diaphragm  
Spring-return cylinder  
Double-acting cylinder

Handwheel: Optional

# Numbering System

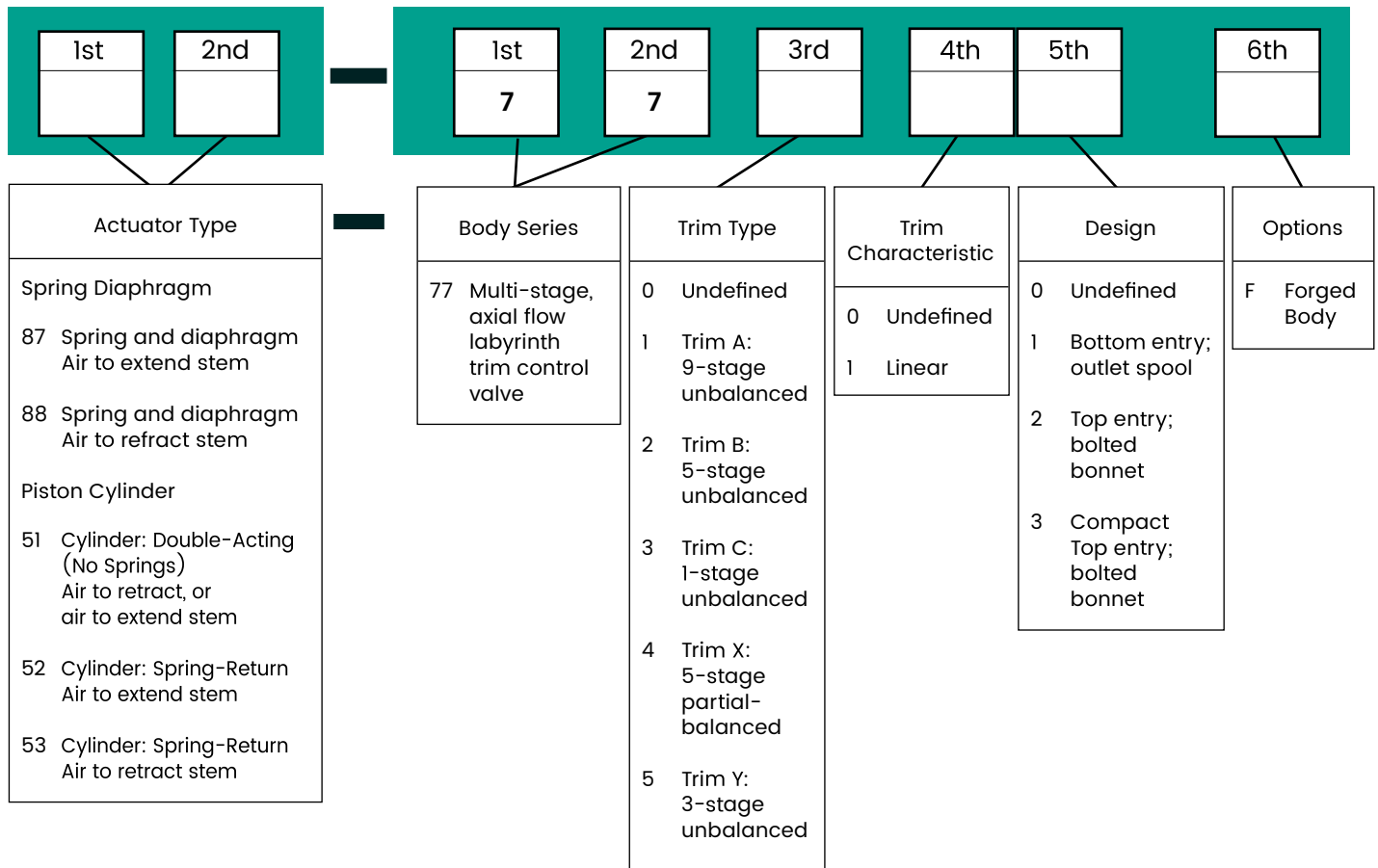

## 77000/77003 Expanding Area Trim Design

The circumference of each pressure reduction stage within the 77000/77003 series trim is designed to gradually increase as flow moves towards the downstream section. This expansion compensates for the change in gas density with the pressure and ensures a nearly constant fluid velocity throughout the complete throttling process, providing the valve with two advantages:

1. Reduction in noise produced by the fluid velocity
2. Considerable decrease in erosion of the plug and seat liner caused by particulate in the flow stream or fluid flashing.

For many applications that experience flashing service conditions, such as super critical power plant start-up valves or hot high-pressure separator letdown in refineries, the 77000/77003 series valve provides a low-velocity outlet area to minimize any effect of the phase transformation process. Similarly, for applications with entrained solids, such as gas wellhead choke applications, the valve reduces the velocity of the moving particulate to minimize wear and erosive damage to the trim and outlet flow area.

Many designs include a larger outlet compared to the inlet size to retain the low velocity as the fluid exits the valve into the downstream piping. This arrangement eliminates the need for additional piping modifications, such as downstream reducers.

# 77000/77003 Series High-Pressure Labyrinth Trim Control Valve



**77003 Series Top Entry**

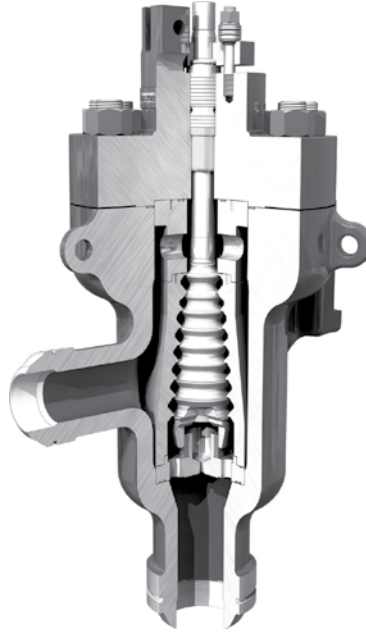

**77002 Series Top Entry**



**77001 Series Bottom Entry**

# 77003 Series Data

## 77003 Sizes and Ratings (ANSI Class)

□RF Flange   ●Socket Weld   ○Threaded   ◆RTJ Flange   ■Butt Weld

Valve Size (inch)	Outlet Options	ANSI 600 API 2000	ANSI 900 API 3000	ANSI 1500 API 5000	ANSI 2500 API 10000
2	2	□●○◆■	□●○◆■	□●○◆■	□●○◆■
	3	□●○◆■	□●○◆■	□●○◆■	□●○◆■
3	3	□◆■	□◆■	□◆■	□◆■
	4	□◆■	□◆■	□◆■	□◆■
4	4	□◆■	□◆■	□◆■	□◆■
	6	□◆■	□◆■	□◆■	□◆■
6	6	□◆■	□◆■	□◆■	□◆■
	8	□◆■	□◆■	□◆■	□◆■
8	8	□◆■	□◆■	□◆■	□◆■
	10	□◆■	□◆■	□◆■	□◆■

Note: API and special valve connections available upon request

## 77003 Flow Coefficient (C<sub>v</sub>) and Expansion Ratio

Valve Size (inch)	Outlet Options (inch)	Trim Size			
		X		Y	
		Expansion Ratio	C <sub>v</sub>	Expansion Ratio	C <sub>v</sub>
2	2	3:1	15	2:6	25
	3	3:1	15	2:6	25
3	3	3:1	30	2:6	48
	4	3:1	30	2:6	48
4	4	3:1	52	2:6	85
	6	3:1	52	2:6	85
6	6	3:1	75	2:6	120
	8	3:1	75	2:6	120
8	8	3:1	120	2:6	200
	10	3:1	120	2:6	200

Note: Special designs with oversized and reduced C<sub>v</sub> trim are available. Please consult Baker Hughes.

## 77003 Temperature Range/Seat Leakage

Valve Size	ANSI Class	API Rating	Trim Type	Seat Type	Temperature Range		Seat Leakage
					Min.	Max.	
2" through 8"	600 through 2500	2000 through 10000	Partially Balanced or Unbalanced	Metal	-29° C (-20° F)	454° C (850° F)	IV or V

1. Designs for higher or lower temperatures are available. Please consult Baker Hughes.

2. Seat leakage class ratings per IEC 534-4 and ANSI/FCI 70.2. Class IV is the standard and Class V is optional.

3. Inlet and outlet connections also available with API size ranges.

# 77003 Series - Carbon steel & CrMo steel Material Options

**77003  
3-Stage**

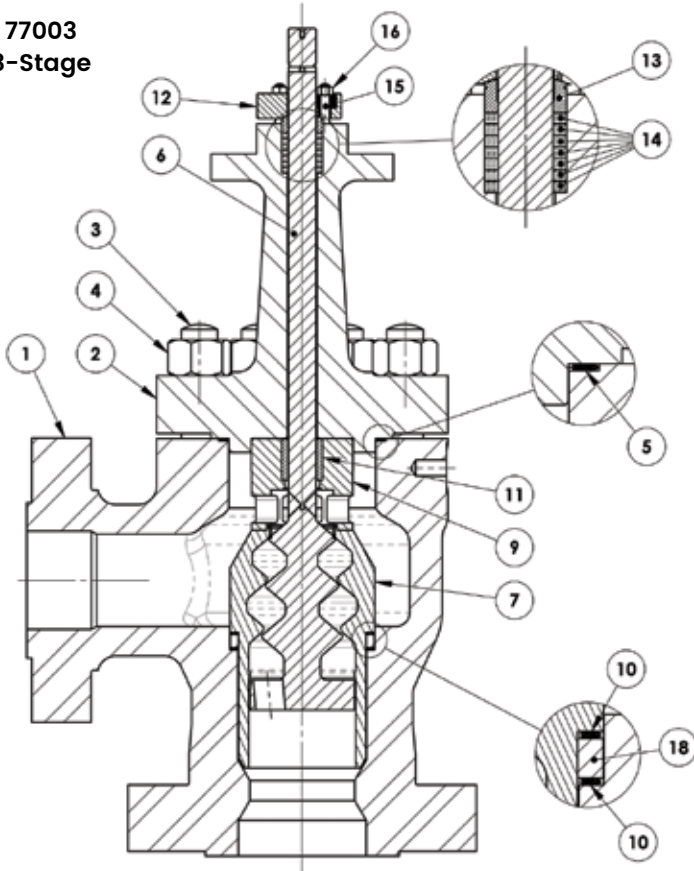

**77003  
5-Stage**

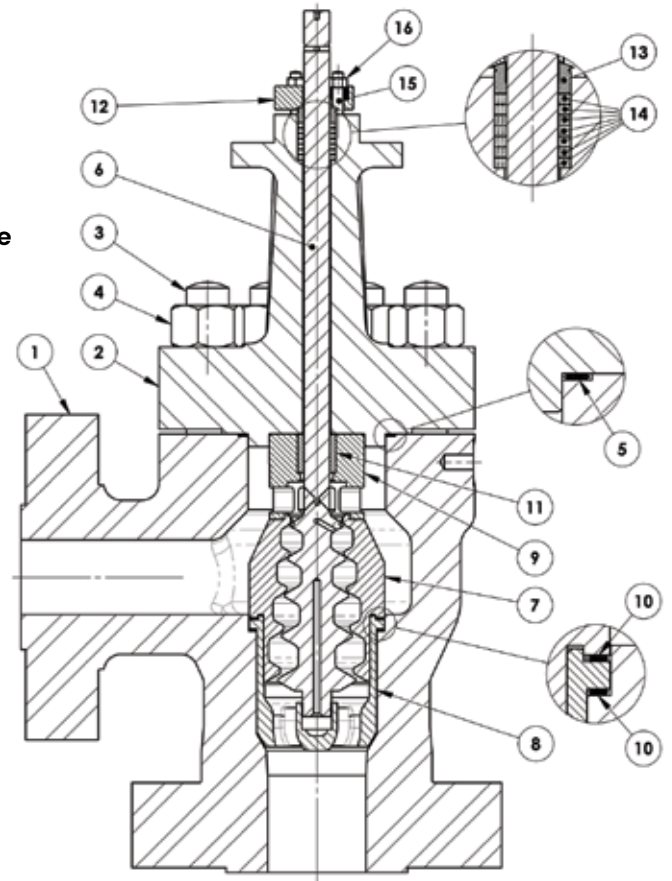



## Carbon Steel and CrMo Steel Construction

Ref. No.	Temperature Range		-29°C (-20°F)	427°C (800°F)	454°C (850°F)
	Description	Notes	Materials		
1 & 2	Body & Bonnet		ASTM 216 GR WCC/WCB / EN 1.619/1.625		
			ASTM A217 Grade WC6 / EN 1.7357		
			ASTM A217 Grade WC9		
3	Body Stud		ASTM A193 B7		ASTM A193 GR B16
4	Body Nut		ASTM A194 2H		ASTM A194 GR 7
5	Body Gasket		316L Stainless Spiral Windings + Graphite Filler		
6	Plus/Stem		6NM Stainless Nitrided + Stellite HF		
			ASTM B637 Alloy N07718 (Inconel 718) Precip Hardened		
7	Liner/Seat		6NM Stainless Nitrided + Stellite HF		
			ASTM Stainless B637 Alloy N07718 (Inconel 718) Precip Hardened		
8	Spider		6NM Nitrided		
			ASTM B637 Alloy N07718 (Inconel 718) Precip Hardened		
9	Retainer		6NM Stainless		
10	Trim Gasket		316L Stainless Spiral Windings + Graphite Filler		
11	Stem Bushing		Stellite No. 6 or Equivalent (UNS 30006)		
12	Packing Flange		Low Carbon Steel Dichromate Zinc Plated		
13	Packing Follower		Solution Annealed 316L Stainless		
14	Packing Set		PTFE/Carbon + Braided Graphite Packing Ring		
15	Packing Studs		ASTM A193 Grade B8 Class 2 (non-exposed)		
			ASTM A193 B7M (exposed)		
16	Packing Nuts		ASTM A194 Grade 8		
17	Actuator Bolts		ASTM A193 GR B7 ZINC PLATED		

## Carbon Steel and CrMo Steel Construction for NACE MR 01-75 2002 or MR 01-03 2003

Ref. No.	Temperature Range		-29°C (-20°F)	C (800°F) 427°	454°C (850°)
	Description	Notes	Materials		
1 & 2	Body & Bonnet		ASTM A216 GR WCC/WCB / EN 1.619/1.625		
			ASTM A217 GR WC6 / EN 1.7357		
			ASTM A217 GR WC9		
3	Body Stud	NACE non-exposed	ASTM A193 GR B7		ASTM A193 GR B16
		NACE exposed	ASTM A193 GR B7M		ASTM A453 GR 660
4	Body Nut	NACE non-exposed	ASTM A194 GR 2H		ASTM A194 GR 7
		NACE exposed	ASTM A194 GR 2HM		ASTM A194 GR 8
5	Body Gasket		316L Stainless Spiral Windings + Graphite Filler		
6	Plug/Stem		6NM Stainless Hard Electroless Nickel Plated + Stellite HF		
			ASTM B637 Alloy N07718 (Inconel 718) Precip Hardened		
7	Liner/Seat		6NM Stainless Hard Electroless Nickel Plated + Stellite HF		
			ASTM B637 Alloy N07718 (Inconel 718) Precip Hardened		
8	Spider		6NM Stainless Hard Electroless Nickel Plated		
			ASTM B637 Alloy N07718 (Inconel 718) Precip Hardened		
9	Retainer		6NM Stainless		
10	Trim Gasket		316L Stainless Spiral Windings + Graphite Filler		
11	Stem Bushing		Stellite No. 6 or Equivalent (UNS 30006)		
12	Packing Flange		Low Carbon Steel Dichromate Zinc Plated		
13	Packing Follower		Solution Annealed 316L Stainless		
14	Packing Set		PTFE/Carbon + Braided Graphite Packing Ring		
15	Packing Studs	NACE non-exposed	ASTM A193 Grade B8 Class 2		
		NACE exposed	ASTM A193 GR B7M Electroless Nickel Plated		
16	Packing Nuts		ASTM A194 Grade 8		
17	Actuator Bolts	NACE non-exposed	ASTM A193 GR B7 Zinc Plated		
		NACE exposed	ASTM A193 GR B7M Electroless Nickel Plated		

# 77003 Series – Material Options

## Stainless Steel Construction

Ref. No.	Temperature Range	-29°C (-20°F)			343°C (650°F)			°C (800°F)			427			454°C (850°F)		
	Description	Materials														
1 & 2	Body & Bonnet	ASTM A351 GR CF8M														
		ASTM A351 GR CF8C														
3	Body Stud	ASTM A193 GR B7 Zinc Plated				ASTM A193 GR B7			ASTM A193 GR B16							
		ASTM A453 GR 660														
4	Body Nut	ASTM A194 GR 2H Zinc Plated				ASTM A194 GR 2H			ASTM A194 GR 7							
		ASTM A194 GR 8														
5	Body Gasket	316L Stainless Spiral Windings + Graphite Filler														
6	Plug/Stem	347 Stainless Hard Electroless Nickel Plated with Stellite HF														
		316 Stainless Hard Electroless Nickel Plated with Stellite HF														
7	Liner/Seat	347 Stainless Hard Electroless Nickel Plated with Stellite HF														
		316 Stainless Hard Electroless Nickel Plated with Stellite HF														
8	Spider	347 Stainless Hard Electroless Nickel Plated														
		316 Stainless Hard Electroless Nickel Plated														
9	Retainer	Solution Annealed 316 Stainless														
10	Trim Gasket	316L Stainless Spiral Windings + Graphite Filler														
11	Stem Bushing	Stellite No. 6 (UNS 30006)														
12	Packing Flange	Solution Annealed 316 Stainless														
13	Packing Follower	Solution Annealed 316L Stainless														
14	Packing Set	PTFE/Carbon + Braided Graphite Packing Ring														
15	Packing Studs	ASTM A193 GR B8 CLASS 2														
16	Packing Nuts	ASTM A194 GR 8														
17	Actuator Bolts	ASTM A193 GR B8 CLASS 2														

# 77003 Series – Material Options

## Stainless Steel Construction for NACE MR 01-75 2002 or MR 01-03 2003

Ref. No.	Temperature Range		-29°C (-20°F)		343°C (650°F)		7°C (80°F)		454°C (850°F)			
	Description	Notes	Materials									
1 & 2	Body Bonnet		ASTM A351 Grade CF8M ASTM A351 Grade CF8C									
3	Body Stud	NACE non-exposed	ASTM A193 GR B7 Zinc Plated						ASTM A193 GR B7		ASTM A193 GR B16	
		NACE exposed	ASTM A193 GR B7M Electroless Nickel Plated ASTM A453 Grade 660									
4	Body Nut	NACE non-exposed	ASTM A194 GR 2H Zinc Plated						ASTM A194 GR 2H		ASTM A194 GR 7	
		NACE exposed	ASTM A194 GR 2HM Zinc Plated ASTM A194 GR 8									
5	Body Gasket		316L Stainless Spiral Windings + Graphite Filler									
6	Plug/Stem		347 Stainless Hard Electroless Nickel Plated + Stellite HF									
			316 Stainless Hard Electroless Nickel Plated + Stellite HF									
7	Liner/Seat		347 Stainless Hard Electroless Nickel Plated + Stellite HF									
			316 Stainless Hard Electroless Nickel Plated + Stellite HF									
8	Spider		347 Stainless Hard Electroless Nickel Plated									
			316 Stainless Hard Electroless Nickel Plated									
9	Retainer		Solution Annealed 316 Stainless									
10	Trim Gasket		Stellite No. 6 (UNS 30006)									
11	Stem Bushing		316L Stainless Spiral Windings + Graphite Filler									
12	Packing Flange		Solution Annealed 316 Stainless									
13	Packing Follower		Solution Annealed 316L Stainless									
14	Packet Set		PTFE/Carbon + Braided Graphite Packing Ring									
15	Packing Studs	NACE non-exposed	ASTM A193 GR B8 Class 2									
		NACE exposed	ASTM A193 GR B7M									
16	Packing Nuts		ASTM A194 GR 8									
17	Acuator Bolts	NACE non-exposed	ASTM A193 GR B8 Class 2									
		NACE exposed	ASTM A193 GR B7M Electroless Nickel Plated									

## 77003 Standard Dimensions

### English Units

Pressure Class	ASME Class 600			ASME Class 900			ASME Class 1500			ASME Class 2500		
	RF/RTJ/BW		Weight (lb)	RF/RTJ/BW		Weight (lb)	RF/RTJ/BW		Weight (lb)	RF/RTJ/BW		Weight (lb)
	C	D		C	D		C	D		C	D	
2 x 3	22.87	9.69	245	22.87	9.69	270	22.87	9.69	289	27.13	10.51	538
3 x 4	27.01	10.59	399	27.01	10.59	424	27.01	10.59	461	30.71	11.69	761
4 x 6	29.61	12.01	631	29.61	12.01	682	29.61	12.01	754	34.80	14.25	1252
6 x 8	38.43	15.12	1106	38.43	15.12	1218	38.43	15.12	1358	42.83	17.32	2168
8 x 10	39.57	17.72	1896	39.57	17.72	2050	39.57	17.72	2322	51.38	19.61	3998

### Metric Units

Pressure Class	ASME Class 600			ASME Class 900			ASME Class 1500			ASME Class 2500		
	RF/RTJ/BW		Weight (kg)	RF/RTJ/BW		Weight (kg)	RF/RTJ/BW		Weight (kg)	RF/RTJ/BW		Weight (kg)
	C	D		C	D		C	D		C	D	
50 x 80	581	246	111	581	246	122	581	246	131	689	267	244
80 x 100	686	269	181	686	269	192	686	269	209	780	297	345
100 x 150	752	305	286	752	305	309	752	305	342	884	362	568
150 x 200	976	384	502	976	384	553	976	384	616	1088	440	983
200 x 250	1005	450	860	1005	450	930	1005	450	1053	1305	498	1813

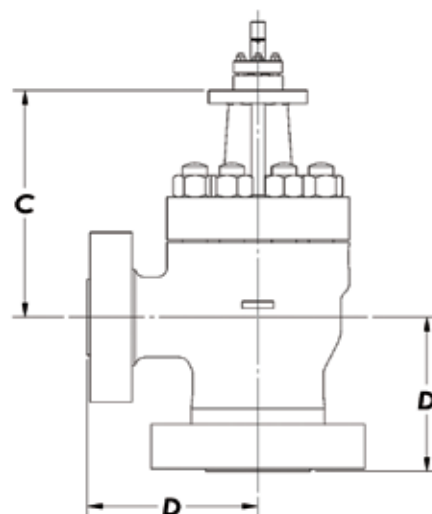

Note: For 77000, consult factory for dimensional data.

# 77000 Series Data

## 77000 Sizes and Ratings (ANSI Class)

□RF Flange   ●Socket Weld   ○Threaded   ◆RTJ Flange   ■Butt Weld

Valve Size (inch)	Outlet Options	ANSI 600 API 2000	ANSI 900 API 3000	ANSI 1500 API 5000	ANSI 2500 API 10000
1	1	□○◆■	□○○◆■	□○○◆■	□○○◆■
	2	□○◆■	□○○◆■	□○○◆■	□○○◆■
	3	□○◆■	□○○◆■	□○○◆■	□○○◆■
2	2	□○◆■	□○○◆■	□○○◆■	□○○◆■
	3	□○◆■	□○○◆■	□○○◆■	□○○◆■
	4	□○◆■	□○○◆■	□○○◆■	□○○◆■
3	3	□◆■	□◆■	□◆■	□◆■
	4	□◆■	□◆■	□◆■	□◆■
	6	□◆■	□◆■	□◆■	□◆■
4	4	□◆■	□◆■	□◆■	□◆■
	6	□◆■	□◆■	□◆■	□◆■
	8	□◆■	□◆■	□◆■	□◆■
6	6	□◆■	□◆■	□◆■	□◆■
	8	□◆■	□◆■	□◆■	□◆■
	10	□◆■	□◆■	□◆■	□◆■
8	8	□◆■	□◆■	□◆■	□◆■
	10	□◆■	□◆■	□◆■	□◆■
	12	□◆■	□◆■	□◆■	□◆■

Note: API and special valve connections available upon request.

# 77000 Series Ratings

## 77000 Flow Coefficient (C<sub>v</sub>) and Expansion Ratio

Valve Size (inch)	Outlet Options (inch)	Trim Size					
		A		B		C	
		Expansion Ratio	C <sub>v</sub>	Expansion Ratio	C <sub>v</sub>	Expansion Ratio	C <sub>v</sub>
1	1	4:1	2	2:1	4	1.5:1	6
	2	4:1	2	2:1	4	1.5:1	6
	3	4:1	2	2:1	4	1.5:1	6
2	2	4:1	12	2:1	22	1.5:1	35
	3	4:1	12	2:1	22	1.5:1	35
	4	4:1	12	2:1	22	1.5:1	35
3	3	4:1	31	2:1	45	1.5:1	72
	4	4:1	31	2:1	45	1.5:1	72
	6	4:1	31	2:1	45	1.5:1	72
4	4	4:1	54	2:1	72	1.5:1	110
	6	4:1	54	2:1	72	1.5:1	110
	8	4:1	54	2:1	72	1.5:1	110
6	6	4:1	72	2:1	120	1.5:1	170
	8	4:1	72	2:1	120	1.5:1	170
	10	4:1	72	2:1	120	1.5:1	170
8	8	4:1	120	2:1	180	1.5:1	260
	10	4:1	120	2:1	180	1.5:1	260
	12	4:1	120	2:1	180	1.5:1	260

Note: Special designs with oversized and reduced C<sub>v</sub> trim are available. Please consult Baker Hughes.

## 77000 Series Temperature Range/Seat Leakage

Valve Size <sup>3</sup>	ANSI Class	API Rating	Trim Type	Seat Type	Temperature Range <sup>1</sup>		Seat Leakage <sup>2</sup>
					Min.	Max.	
1-inch through 8-inch	600 through 2500	2000 through 10000	Unbalanced	Metal	-29° C (-20° F)	565° C (1050° F)	IV or V

1. Designs for higher or lower temperatures are available. Please consult Baker Hughes.

2. Seat leakage class ratings per IEC 534-4 and ANSI/FCI 70.2. Class IV is the standard and Class V is optional.

3. Inlet and outlet connections also available with API size ranges.



# 77001 Series – Bottom Entry Material Options

Ref No.	Temperature Range	Standard Materials and Optional Materials			
		-29°C (-20°F)	340°C (650°C)	427°C (800°F)	510°C (950°F) 565°C
	Description				
1	Body	ASTM A216 WCC Carbon Steel/ASTM A105 Carbon Steel			
		ASTM A217 WC6 Chrome-Moly/ASTM A182 F11 Chrome-Moly			
		ASTM A217 WC9 Chrome-Moly/ASTM A182 F22 Chrome-Moly			
		ASTM A351 CF8M Stainless Steel/ASTM A182 F316 Stainless Steel			
		ASTM A351 CF8C Stainless Steel/ASTM A182 F347 Stainless Steel			
2	Outlet Spool	ASTM A216 WCC Carbon Steel/ASTM A105 Carbon Steel			
		ASTM A217 WC6 Chrome-Moly/ASTM A182 F11 Chrome-Moly			
		ASTM A217 WC9 Chrome-Moly/ASTM A182 F22 Chrome-Moly			
		ASTM A351 CF8M Stainless Steel/ASTM A182 F316 Stainless Steel			
		ASTM A351 CF8C Stainless Steel/ASTM A182 F347 Stainless Steel			
3	Seat Ring	316 St. St. or 347 St. St. Boronized with Hardfaced Seat			
4	Spider	316 St. St. or 347 St. St.			
5	Plug Stem	316 St. St. or 347 St. St. Boronized with Hardfaced Seat			
6	Stem Guide Bushing	Stellite 6 UNS 30006			
7	Lower Spider Gasket	316 St. St. with Flexible Graphite Filler (Spiral Wound)	Inconel with Graphite (Spiral Wound)		
8	Upper Spider Gasket	316 St. St. with Flexible Graphite Filler (Spiral Wound)	Inconel with Graphite (Spiral Wound)		
9	Body Stud <sup>1</sup>	ASTM A193 Gr B7 <sup>2</sup> or ASTM A193 Gr B7M <sup>2</sup>	ASTM A193 Gr B16	ASTM A453 Gr 660	
10	Bonnet/Spool Nut <sup>1</sup>	ASTM A194 Gr 2H <sup>2</sup> or ASTM A19F Gr2HM <sup>2</sup>	ASTM A194 Gr 4	ASTM A194 Gr 8	
11	Packing Set	Teflon V-Ring	Flexible Graphite		
12	Lantern Ring	300 Series Stainless Steel			
13	Packing Follower	300 Series Stainless Steel			
14	Packing Flange	300 Series Stainless Steel or Chrome Moly			
15	Packing Flange Stud <sup>1</sup>	304 Stainless Steel ASTM A193 Gr B8 Class 2 <sup>2</sup> or ASTM A193 Gr B7M Nickel Plated <sup>2</sup>			
16	Packing Flange Nut <sup>1</sup>	304 Stainless Steel ASTM A194 Gr 8 <sup>2</sup> or ASTM A194 Gr 2HM Nickel Plated <sup>2</sup>			
17	Actuator Toggle Bracket	ASTM A36 Carbon Steel			
18	Bracket Stud <sup>1</sup>	ASTM A193 Gr B7			
19	Bracket Nut <sup>1</sup>	ASTM A194 Gr 2H			
20	Body Clevis	ASTM A36 Carbon Steel			
21	Body Clevis Pin	440 C Stainless Steel			
22	Body Clevis Retaining Ring	ASTM A564 Gr 632			
23	Lever	ASTM A36 Carbon Steel			
24	Stem Pivot Adapter	300 Series Stainless Steel			
25	Anti-Rotation Screw	300 Series Stainless Steel			
26	Locknut	ASTM A194 Gr 8			
27	Actuator Link Connector	300 Series Stainless Steel			
28	Actuator Link Pin	440 C Stainless Steel			
29	Actuator Link Retaining Ring	ASTM A564 Gr 632			
30	Travel Stop Stud	300 Series Stainless Steel			
31	Travel Stop Nut	300 Series Stainless Steel			
32	Drive Nut	Carbon Steel ASTM A668 CL B or ASTM A2165 Gr WCC			
36	Spud Adapter	300 Series Stainless Steel			
37	Actuator Link Clevis (Sizes from 1-3 inches)	ASTM A36 Carbon Steel			

1. Studs and Nuts are Nickel or Zinc Plated for use with Stainless Steel Bodies.

2. Non-Nace and Nace Non-Exposed (Class III)

3. Nace Exposed (Class I & II)

# 77002 Series - Top Entry

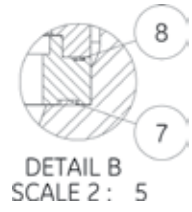
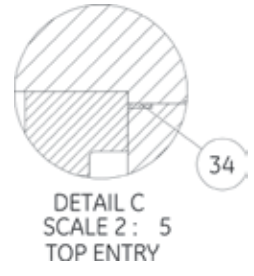
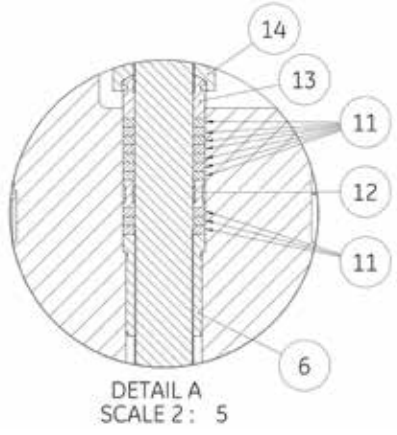
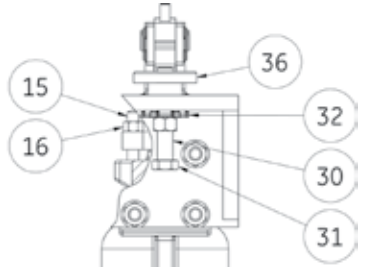
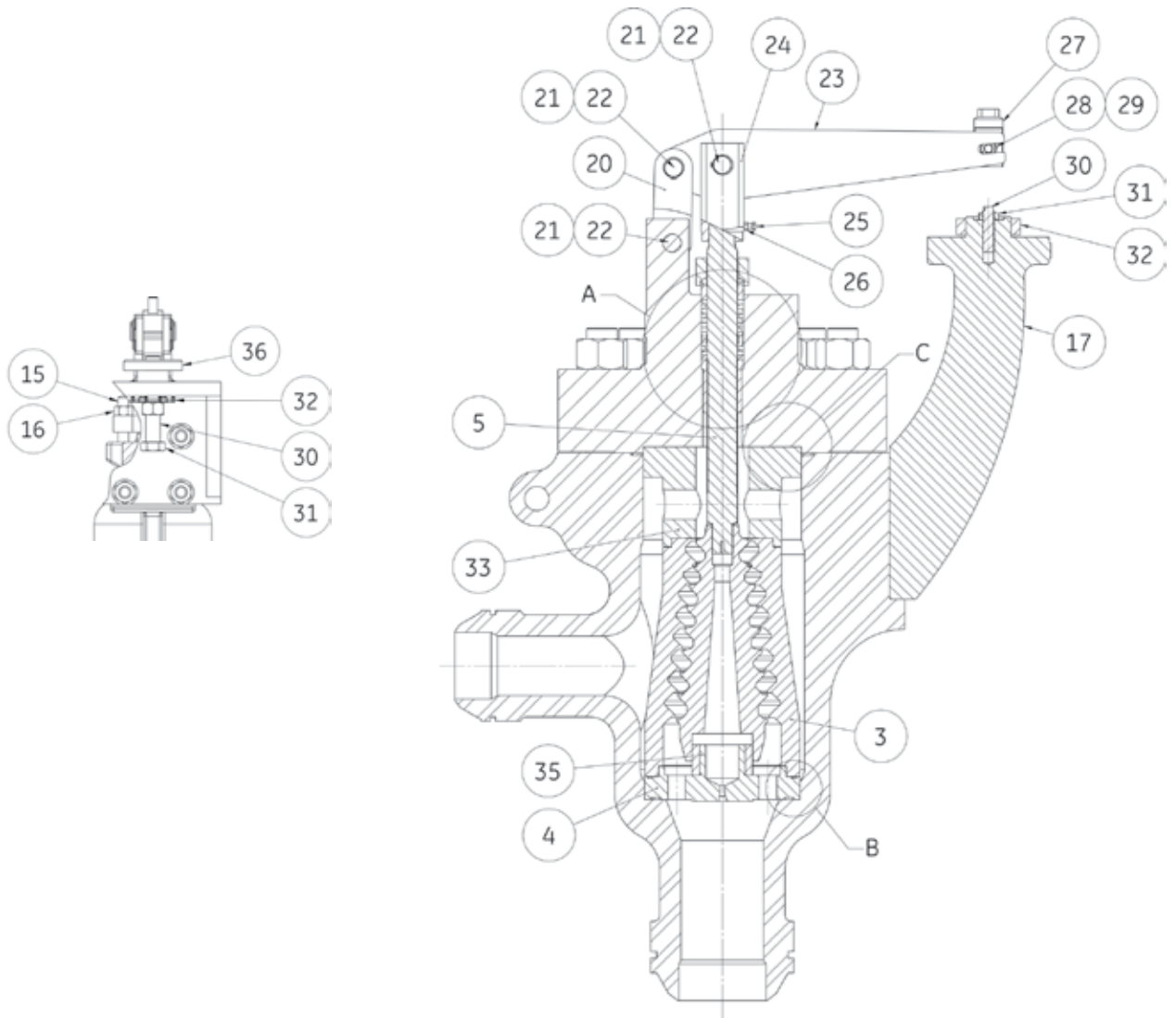



# 77002 Series – Top Entry Material Options

Ref No.	Temperature Range	-29°C (-20°F)	340°C (650°F)	427°C (800°F)	510°C (950°F)	565°C (1050°F)
		Standard Materials and Optional Materials				
1	Body	ASTM A216 WCC Carbon Steel/ASTM A105 Carbon Steel				
		ASTM A217 WC6 Chrome-Moly/ASTM A182 F11 Chrome-Moly				
		ASTM A217 WC9 Chrome-Moly/ASTM A182 F22 Chrome-Moly				
		ASTM A351 CF8M Stainless Steel/ASTM A182 F316 Stainless Steel ASTM A351 CF8C Stainless Steel/ASTM A182 F347 Stainless Steel				
2	Bonnet	ASTM A216 WCC Carbon Steel/ASTM A105 Carbon Steel				
		ASTM A217 WC6 Chrome-Moly/ STM A182 F11 Chrome-Moly				
		ASTM A217 WC9 Chrome-Moly/ASTM A182 F22 Chrome-Moly				
		ASTM A351 CF8M Stainless Steel/ASTM A182 F316 Stainless Steel ASTM A351 CF8C Stainless Steel/ASTM A182 F347 Stainless Steel				
3	Seat Ring	316 St. St. or 347 St. St. Boronized with Hardfaced Seat				
4	Spider	316 St. St. or 347 St. St.				
5	Plug Stem	316 St. St. or 347 St. St. Boronized with Hardfaced Seat				
6	Stem Guide Bushing	Stellite 6 UNS 30006				
7	Lower Spider Gasket	316 St. St. with Flexible Graphite Filler (Spiral Wound)		Inconel w/ Graphite (Spiral Wound)		
8	Upper Spider Gasket	316 St. St. with Flexible Graphite Filler (Spiral Wound)		Inconel w/ Graphite (Spiral Wound)		
9	Body Stud <sup>1</sup>	ASTM A193 Gr B7 <sup>2</sup> or ASTM A193 Gr B7M <sup>2</sup>			ASTM A193 Gr B16	ASTM A453 Gr 660
10	Bonnet/Spool Nut <sup>1</sup>	ASTM A194 Gr 2H <sup>2</sup> or ASTM A193 Gr 2HM <sup>2</sup>			ASTM A194 Gr 4	ASTM A194 Gr 8
11	Packing Set	Teflon V-Ring		Flexible Graphite		
12	Lantern Ring	300 Series Stainless Steel				
13	Packing Follower	300 Series Stainless Steel				
14	Packing Flange	300 Series Stainless Steel or Chrome Moly				
15	Packing Flange Stud <sup>1</sup>	304 Stainless Steel ASTM A193 Gr B8 Class 2 <sup>2</sup> or ASTM A193 Gr B7M Nickel Plated <sup>2</sup>				
16	Packing Flange Nut <sup>1</sup>	304 Stainless Steel ASTM A194 Gr 8 <sup>2</sup> or ASTM A194 Gr 2HM Nickel Plated <sup>2</sup>				
17	Actuator Toggle Bracket	ASTM A36 Carbon Steel				
18	Bracket Stud <sup>1</sup>	ASTM A193 Gr B7				
19	Bracket Nut <sup>1</sup>	ASTM A194 Gr 2H				
20	Body Clevis	ASTM A36 Carbon Steel				
21	Body Clevis Pin	440 C Stainless Steel				
22	Body Clevis Retaining Ring	ASTM A564 Gr 632				
23	Lever	ASTM A36 Carbon Steel				
24	Stem Pivot Adapter	300 Series Stainless Steel				
25	Anti-Rotation Screw	300 Series Stainless Steel				
26	Locknut	ASTM A194 Gr 8				
27	Actuator Link Connector	300 Series Stainless Steel				
28	Actuator Link Pin	440 C Stainless Steel				
29	Actuator Link Retaining Ring	ASTM A564 Gr 632				
30	Travel Stop Stud	300 Series Stainless Steel				
31	Travel Stop Nut	300 Series Stainless Steel				
32	Drive Nut	Carbon Steel ASTM A668 CL B or ASTM A2165 Gr WCC				
33	Seat Ring Retainer	316 St. St. or 347 St. St.				
34	Bonnet Gasket	316 St. St. with Flexible Graphite Filler (Spiral Wound)		Inconel with Graphite (Spiral Wound)		
35	Lower Guide Bushing	RTFE		Stellite 6 UNS 30006		
37	Actuator Link Clevis (Sizes from 1 to 3 inches)	ASTM A36 Carbon Steel				
38	Conical Spring	Inconel 718				

1. Studs and Nuts are Nickel or Zinc Plated for use with Stainless Steel Bodies.

2. Non-Nace and Nace Non-Exposed (Class III)



CONTROLS SUPPLY CHAIN

VALVES ACTUATORS INSTRUMENTATIONS