



## TF 974 / 976

# Oil burner safety control

**For 1- or 2-stage oil burners up to 30 kg/h throughput and intermittent operation with or without oil preheating**

**Flame detection:**

- Photo resistor MZ 770 S
- Infrared-flicker detector IRD 1010
- UV flame sensor UVD 970

### INTRODUCTION

The TF 974 or TF 976 oil burner safety control boxes are suitable for oil burners which may be equipped with a oil preheater up to 30 kg/h capacity. The control boxes are approved and certified according to EN 230.

A special contact in the control unit short-circuits the thermo-switch of the fuel heater as soon as the burner is operating and the flame signal is present. Therefore interruption of the burner operation due to decreasing oil temperature can be prevented (e.g. in case of high oil flow).

If the control box goes into lock-out mode, the oil preheater power supply is also disconnected.

### TYPES AVAILABLE

- |        |  |
|--------|--|
| TF 974 | 1-stage operation<br>post-ignition time ca. 20 sec.<br>low voltage protection according to EN 230    |
| TF 976 | 2-stage operation<br>post-ignition time ca. 2 - 4 sec.<br>low voltage protection according to EN 230 |

### CONSTRUCTIONAL FEATURES

The control box circuitry is protected by a flame resistant, transparent housing. It incorporates the thermomechanical, temperature composated, flame check and reset circuits.

Manual reset from lockout is provided by a push button with an integrated lockout signal lamp. A central fixing screw locks the control box to the wiring base. The wiring base and control box have a positive plug-in arrangement, making it impossible to achieve an incorrect connection between the two parts.

A variety of cable entry points provides the utmost flexibility for electrical wiring.



### TECHNICAL DATA

Operating voltage	220 / 240 V (-15... +10%) 50 Hz (40 - 60 Hz)
Fuse rating	10 A fast, 6 A slow
Power consumption	ca. 5 VA
Max. current rating output terminal	term. 2 0.5 A, cos φ 0.4 term. 3 1.5 A, cos φ 0.2 term. 4 4 A, cos φ 0.4 term. 5 0.5 A, cos φ 0.4 term. 6 4 A, cos φ 0.4 term. 8 0.1 A, cos φ 0.4 total 5 A, cos φ 0.4
Pre-purge time	ca. 12 sec.
Pre-ignition time	ca. 12 sec.
Post-ignition time	ca. 20 sec. TF 974 2 - 4 sec. TF 976
Delay time to oil valve V 2	ca. 20 sec. TF 976
Lockout safety time	10 sec.
Reset time from lockout	ca. 60 sec.
Flame detector	
MZ 770 S	for side-on and end-on viewing
Light sensitivity	> 6 Lux
Sensor operating current	min. 30 µA
IRD 1010	for side-on or end-on viewing
UVD 970	end-on viewing
Weight incl. wiring base	0,25 kg
Mounting position	any
Protection class	IP 40
Recommended ambient operating temperature for control and flame detector approved according to	0° C... +60° C EN 230

## UV SOLID STATE SENSOR UVD 970 APPLICATION NOTES

### 1. Flame control

The following flame detectors can be used for flame control:

- For yellow oil flame: photoresistor MZ 770 S (side-on or end-on viewing).
- For blue or yellow oil flame: infrared-flame detector type IRD 1010 or as an alternative the UV solid state sensor UVD 970.

Generally, the no flame signal is generated at light levels below 3 Lux with respect to the operating cycle of the control. According to EN 230 stray light safety level has to be established in conjunction with the accompanying burner. Connecting the IRD 1010 or UVD 970, the correct wiring has to be observed.

### 2. Burner control

The fuel heater of the burner must have a temperature control switch. The closing contact-switch of the preheater has to be connected between terminals 4 and 6. A special contact in the control unit connects the thermostat of the heater as soon as the burner is operating and a photocurrent is generated. Therefore an interruption of the burner operation due to a decrease in oil temperature is prevented (e.g. high oil flow).

According to EN 230 A2.1, the short circuiting of the thermostat is allowed only for an oil flow of max. 10 kg/h oil. Burners with a higher throughput have to shut down if the oil temperature gets below the allowed minimum. In such a case the thermostat has to be put in the phase circuit and terminals 4 and 6 are connected with a link.

With burners without fuel heaters terminals 4 and 6 have to be connected with a jumper.

### 3. Low Voltage Protection

The start up of the burner can only take place if the mains voltage is higher than a limit which is 15% below nominal value. If the voltage drops below 160V, a start-up is prevented or – without allowing to release the fuel – the control box goes into lock out mode.

### 4. Safety

The design and the control sequence of the TF 974 and TF 976 control boxes comply with the currently applicable European standards and regulations.

### 5. Mounting and electrical wiring

Wiring base:

- 3 earth terminals with additional terminal for burner earthing
- 3 neutral terminals with internal permanent connection to neutral terminal (terminal 7)
- 2 spare auxiliary terminals
- 2 slide-in plates and 2 easy-knockout holes (PG 11 thread), plus 2 easy-knockout holes in the base bottom facilitate the base wiring.

General:

- Control box and flame detector should not be subjected to excessive vibration.
- The control box can be mounted in any position. The protection class is IP 40.

## INSTALLATION INSTRUCTIONS AND MAINTENANCE

### 1. Important notes

- The controls must be installed by qualified personnel only. The relevant national regulations have to be observed.
- On commissioning the wiring has to be carefully checked according to the appropriate diagram. Incorrect wiring can damage the unit and endanger the installation.
- The fuse rating has to ensure that the limits specified in Technical Data will not be exceeded. If these precautions are not observed, the effect of a short circuit can cause severe damage to the control and installation.
- For safety reasons a minimum of one control shut-down per 24 hours has to be observed.
- Disconnect the mains before the control box is plugged in or out!
- The control box is a safety device and must not be opened!

### 2. Function control

For safety reasons the flame detection system should be tested on commissioning the installation as well as after a service or a longer shut-down.

- a) Start-up with covered flame detector:
  - After lock-out safety time
  - > lockout
- b) Start-up with exposed flame detector:
  - After ca. 20 sec. pre-purge:
  - > lockout
- c) Normal start-up; with burner in the "normal" position, cover up the flame detector:
  - New start-up, after end of lock-out safety time
  - > lockout

### 3. Fault finding

Burner not working:

- faulty electrical wiring
- thermostat circuit open
- oil preheater defective
- mains voltage below 160V

Burner starts, flame not established = lockout:

- stray light on flame detector.
- no ignition or no fuel.
- mains voltage more than -15% below nominal value.

Burner starts, flame established, after safety time = lockout:

- dirty or faulty flame detector
- insufficient light on detector
- sensitivity adjustment too low on IRD

### CIRCUIT AND TIMING DIAGRAM TF 974

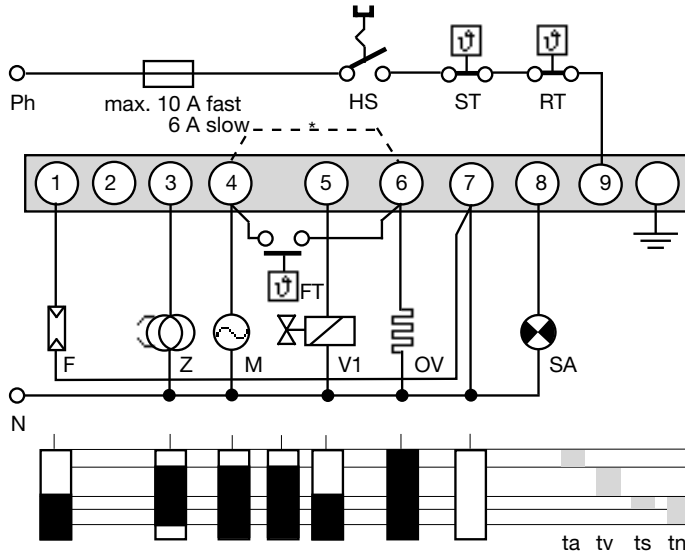

### IRD - / UVD-CONNECTION

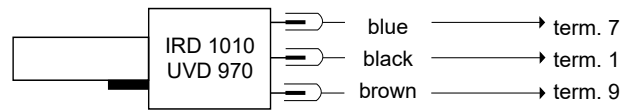

- HS Mains switch
- ST Limit thermostat
- RT Control thermostat
- F Flame detector MZ 770 S (IRD 1010/UVD 970 see separate diagram)
- Z Ignition
- M Burner motor (burner with solenoid valve)
- FT Release thermostat oil preheater
- V Oil solenoid valve
- OV Oil preheater
- SA External lock-out signal.
- \* For burners without fuel heaters terminals 4 and 6 have to be connected with a link.
- ta Preheat-time oil preheater
- tv Pre-ignition time with or without pre-purge
- ts Lock-out safety time
- tn Post-ignition time

### CIRCUIT AND TIMING DIAGRAM TF 976

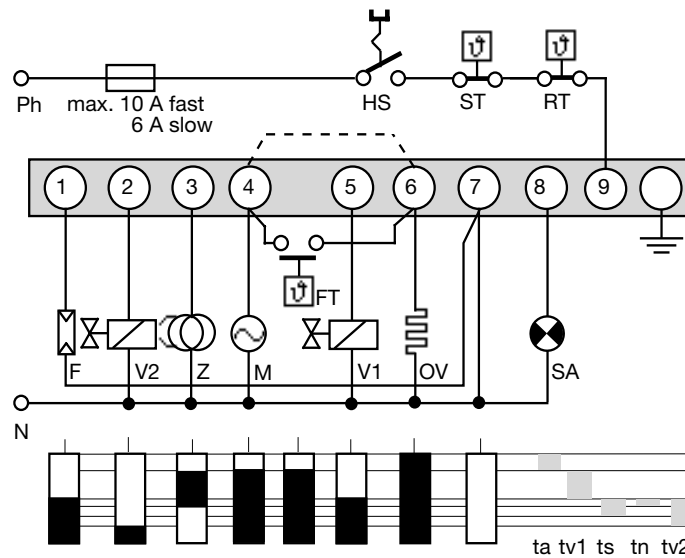

### IRD - / UVD CONNECTION

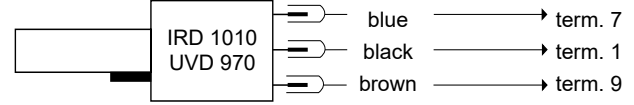

- HS Mains switch
- ST Limit thermostat
- RT Control thermostat
- F Flame detector MZ 770 S (IRD 1010/UVD 970 see separate diagram)
- Z Ignition
- M Burner motor (burner with solenoid valve)
- V1, V2 Oil solenoid valves
- FT Release thermostat oil preheater
- OV Oil preheater
- SA External lock-out signal.
- \* For burners without fuel heater terminals 4 and 6 have to be connected with a link
- ta Preheat-time oil preheater
- tv1 Pre-ignition time with or without pre-purge
- ts Lock-out safety time
- tn Post ignition time
- tv2 Delay 2nd stage

### SCHEMATIC DIAGRAM TF 974

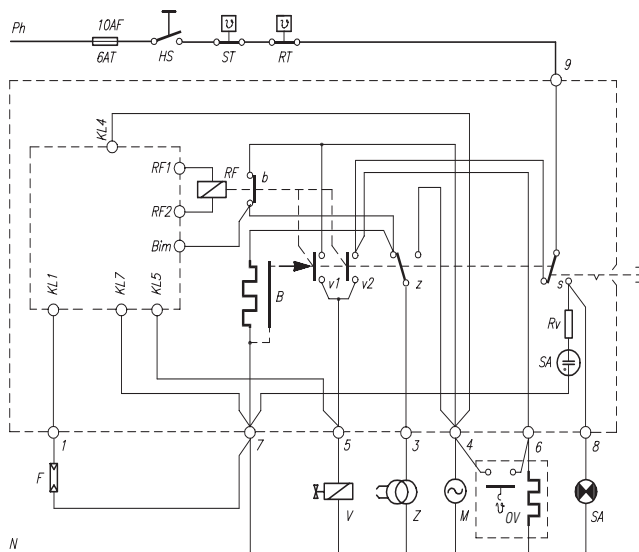

### SCHEMATIC DIAGRAM TF 976

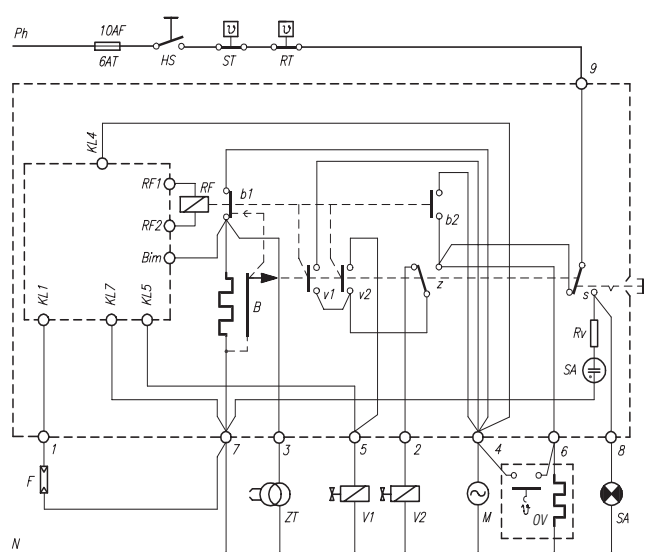

- HS Mains switch
- ST Limit thermostat
- RT Control thermostat
- SA Lock-out signal indicator

- F Flame detector MZ 770 S
- V Valves
- Z Ignition
- M Burner motor

- OV Oil preheater
- RF Flame relay
- B Thermomechanical timer
- RV Resistor

### TF 974 / 976 AND SOCKET

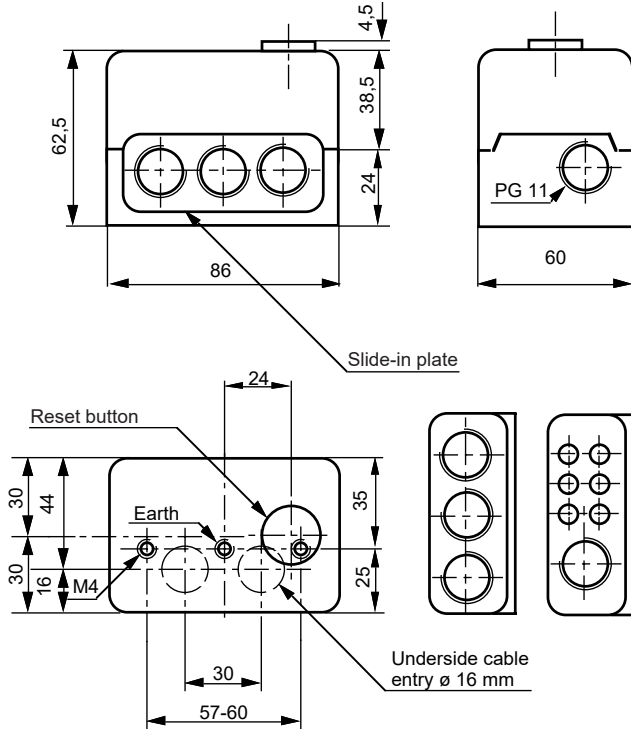

### HOLDER FOR MZ 770 S

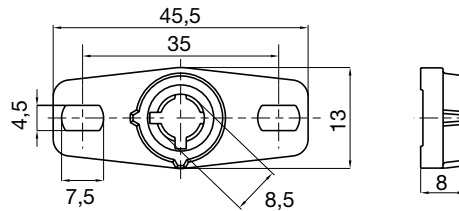

### SHAFT MZ 770 S

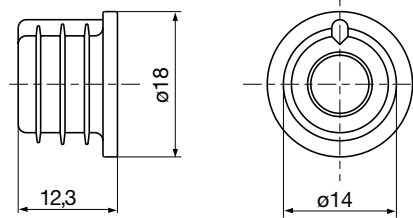

### PHOTORESISTOR MZ 770 S

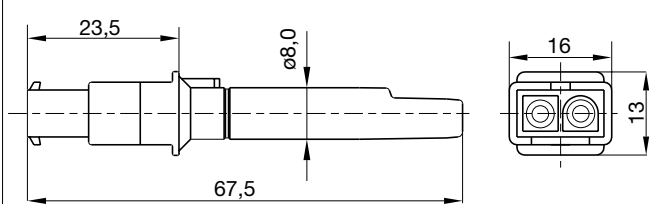

### IRD 1010

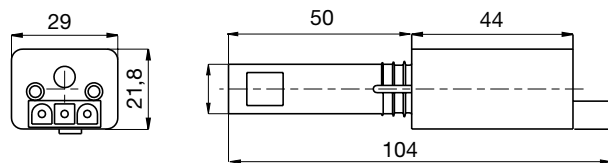

### UVD 974

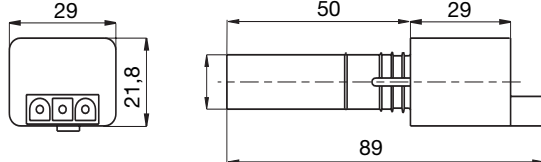

### HOLDER M 74 FOR IRD OR UVD

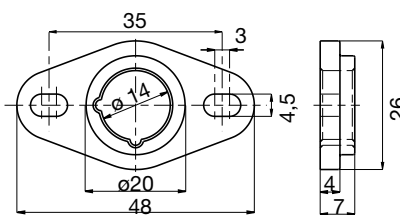

### ORDERING INFORMATION

#### ITEM

Control box

or

Socket

Insert plate

optional

Flame detector

optional

optional

optional

optional

optional

Support for flame detector

optional

Connectioncable

Connectioncable

The above ordering information refers to the standard version.

Special versions are also included in our product range.

#### DESIGNATION

Typ TF 974

Typ TF 976

Socket 701 ABEN 7

PG-Plate

Cable entry plate

MZ 770 S

MZ 770 S with shaft

IRD 1010 right

IRD 1010 end-on

IRD 1010 left

UVD 970

Holder for MZ 770 S

Holder M74 for IRD or UVD

Plug type, 3 core cable, 0.6 m with tag wire ends

Plug type, 2 core cable, 0.6 m with tag wire ends

#### ITEM NO.

02524

02526

70011

70502

70501

50001

51001

16501

16502

16503

16702

59100

59074

7236001

7225001

Specifications subject to change without notice

## TF 974 / 976